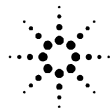


Agilent E4991A RF Impedance/Material Analyzer

Service Manual

Third Edition



Agilent Technologies

Agilent Part No. E4991-90120

November 2004

Printed in Japan

Notices

The information contained in this document is subject to change without notice.

This document contains proprietary information that is protected by copyright. All rights are reserved. No part of this document may be photocopied, reproduced, or translated to another language without the prior written consent of Agilent Technologies.

Microsoft®, MS-DOS®, Windows®, Visual C++®, Visual Basic®, VBA® and Excel® are registered

UNIX is a registered trademark in U.S. and other countries, licensed exclusively through X/Open Company Limited.

Portions ©Copyright 1996, Microsoft Corporation. All rights reserved.

© Copyright 2001, 2003, 2004 Agilent Technologies

Manual Printing History

The manual's printing date and part number indicate its current edition. The printing date changes when a new edition is printed. (Minor corrections and updates that are incorporated at reprint do not cause the date to change.) The manual part number changes when extensive technical changes are incorporated.

December 2001	First Edition
April 2003	Second Edition
November 2004	Third Edition

Safety Summary

The following general safety precautions must be observed during all phases of operation, service, and repair of this instrument. Failure to comply with these precautions or with specific WARNINGS elsewhere in this manual may impair the protection provided by the equipment. In addition it violates safety standards of design, manufacture, and intended use of the instrument.

Agilent Technologies assumes no liability for the customer's failure to comply with these requirements.

NOTE

The E4991A complies with INSTALLATION CATEGORY II as well as POLLUTION DEGREE 2 in IEC61010-1. The E4991A is an INDOOR USE product.

NOTE

The LEDs in the E4991A are Class 1 in accordance with IEC60825-1,

CLASS 1 LED PRODUCT

NOTE This equipment is MEASUREMENT CATEGORY I (CAT I). Do not use for CAT II, III, or IV.

NOTE This equipment is tested with stand-alone condition or with the combination with the accessories supplied by Agilent Technologies against the requirement of the standards described in the Declaration of Conformity. If it is used as a system component, compliance of related regulations and safety requirements are to be confirmed by the builder of the system.

- **Ground the Instrument**
To avoid electric shock, the instrument chassis and cabinet must be grounded with the supplied power cable's grounding prong.
- **DO NOT Operate in an Explosive Atmosphere**
Do not operate the instrument in the presence of inflammable gasses or fumes. Operation of any electrical instrument in such an environment clearly constitutes a safety hazard.
- **Keep Away from Live Circuits**
Operators must not remove instrument covers. Component replacement and internal adjustments must be made by qualified maintenance personnel. Do not replace components with the power cable connected. Under certain conditions, dangerous voltage levels may remain even after the power cable has been disconnected. To avoid injuries, always disconnect the power and discharge circuits before touching them.
- **DO NOT Service or Adjust the Instrument Alone**
Do not attempt internal service or adjustment unless another person, capable of rendering first aid and resuscitation, is present.
- **DO NOT Substitute Parts or Modify the Instrument**
To avoid the danger of introducing additional hazards, do not install substitute parts or perform unauthorized modifications to the instrument. Return the instrument to an Agilent Technologies Sales and Service Office for service and repair to ensure that safety features are maintained in operational condition.
- **Dangerous Procedure Warnings**
Warnings, such as the example below, precede potentially dangerous procedures throughout this manual. Instructions contained in the warnings must be followed.

WARNING **Dangerous voltage levels, capable of causing death, are present in this instrument. Use extreme caution when handling, testing, and adjusting this instrument.**

- Do not connect the measuring terminals to mains.

Safety Symbol

General definitions of safety symbols used on the instrument or in manuals are listed below.



Instruction Manual symbol: the product is marked with this symbol when it is necessary for the user to refer to the instrument manual.



Alternating current.



Direct current.



On (Supply).



Off (Supply).



In position of push-button switch.



Out position of push-button switch.



Frame (or chassis) terminal. A connection to the frame (chassis) of the equipment which normally include all exposed metal structure.

WARNING

This warning sign denotes a hazard. It calls attention to a procedure, practice, condition or the like, which, if not correctly performed or adhered to, could result in injury or death to personnel.

CAUTION

This Caution sign denotes a hazard. It calls attention to a procedure, practice, condition or the like, which, if not correctly performed or adhered to, could result in damage to or destruction of part or all of the product.

NOTE

Note denotes important information. It calls attention to a procedure, practice, condition or the like, which is essential to highlight.

Certification

Agilent Technologies certifies that this product met its published specifications at the time of shipment from the factory. Agilent Technologies further certifies that its calibration measurements are traceable to the United States National Institute of Standards and Technology, to the extent allowed by the Institution's calibration facility, or to the calibration facilities of other International Standards Organization members.

Documentation Warranty

The material contained in this document is provided "as is," and is subject to being changed, without notice, in future editions. Further, to the maximum extent permitted by applicable law, Agilent disclaims all warranties, either express or implied with regard to this manual and any information contained herein, including but not limited to the implied warranties of merchantability and fitness for a particular purpose. Agilent shall not be liable for errors or for incidental or consequential damages in connection with the furnishing, use, or performance of this document or any information contained herein. Should Agilent and the user have a separate written agreement with warranty terms covering the material in this document that conflict with these terms, the warranty terms in the separate agreement will control.

Exclusive Remedies

The remedies provided herein are buyer's sole and exclusive remedies. Agilent Technologies shall not be liable for any direct, indirect, special, incidental, or consequential damages, whether based on contract, tort, or any other legal theory.

Assistance

Product maintenance agreements and other customer assistance agreements are available for Agilent Technologies products.

For any assistance, contact your nearest Agilent Technologies Sales and Service Office. Addresses are provided at the back of this manual.

Typeface Conventions

Bold	Boldface type is used when a term is defined. For example: icons are symbols.
<i>Italic</i>	Italic type is used for emphasis and for titles of manuals and other publications.
[Hardkey]	Indicates a hardkey labeled "Hardkey."
Softkey	Indicates a softkey labeled "Softkey."
[Hardkey] - Softkey1 - Softkey2	Indicates keystrokes [Hardkey] - Softkey1 - Softkey2 .

E4991A Documentation Map

The following manuals are available for the E4991A.

- **Operation Manual (P/N: E4991-900x0)**

Most of basic information necessary for using E4991A is described in this manual. It includes the way of installation, preparation, measurement operation including calibration, performances (specifications), key definitions, and error messages.

- **Programming Manual (P/N: E4991-900x1)**

The Programming Manual shows how to write and use program to control the E4991A.

- **Service Manual (P/N: E4991-901x0)**

This manual describes how to adjust and repair the E4991A, and how to carry out performance tests.

Microsoft®, MS-DOS®, Windows®, and Visual Basic® for Applications are registered trademarks of Microsoft Corporation in U.S. and other countries.

1. General Information	
Organization of Service Manual	16
Instrument Covered by This Manual	18
Required Equipment	19
2. Performance Test and Function Test	
Required Equipment	22
How to Set the E4991A for Maintenance	23
Performance Test	25
Introduction	25
Frequency Accuracy Test	26
Power Level Accuracy Test	29
Impedance Measurement Accuracy Test	33
DC Bias Level Accuracy Test (Option 001)	40
Performance Test (for Option 007 Temperature Characteristic Test Kit)	44
Introduction	44
Required Test	44
Specification	44
Required Equipment	44
Test Procedure	44
Performance Test (for Option 010 Probe Station Connection Kit)	46
Introduction	46
Required Test	46
Specification	46
Required Equipment	47
Test Procedure	48
Function Test	49
Introduction	49
Warm Up Time	49
Ambient Conditions	49
Low Loss Capacitor Check	50
Calculating Sheet	51
Performance Test	51
Function Test	71
Test Record	72
Performance Test Record	72
Performance Test Record (Option 007)	87
Performance Test Record (Option 010)	100
Function Test Record	114
3. Adjustment	
Safety Considerations	116
Warm-up for Adjustment	116
Required Equipment	116
Preparation for using the Adjustment Program	117
Required Controller	117
Installing a GPIB Card (82340B, 82341C/D or 82350A)	117
Installing Agilent VEE for Personal Computer	117

Contents

Installing Adjustment Program into Your PC	117
Equipment Setup	118
E4991A Control Mode.	119
Order of Adjustment.	120
Required Adjustment after Replacing Assembly	122
Adjustment Program.	123
Adjustment Program Menu.	123
How to perform the Adjustment Program	126
Initialization of the System Calibration Data	130
Required Equipment	130
Procedure	130
A1 VCXO Frequency Adjustment	131
Required Equipment	131
Procedure	131
A3 Local Level Adjustment	132
Required Equipment	132
Procedure	132
A3 Output AGC Gain Adjustment	133
Required Equipment	133
Procedure	133
A3 Output Level Adjustment	134
Required Equipment	134
Procedure	134
A4 AGC Gain Adjustment	136
Required Equipment	136
Procedure	136
A4 Local Level Adjustment	137
Required Equipment	137
Procedure	137
A4 IF Gain Adjustment	138
Required Equipment	138
Procedure	138
Default Cal Coefficient Adjustment	139
Required Equipment	139
Procedure	139
A5 Reference Oven Adjustment (Opt 1D5 only).	140
Required Equipment	140
Procedure	140
A2 DC Bias Voltage Adjustment (Opt 001 only).	142
Required Equipment	142
Procedure	142
A2 DC Bias Current Adjustment (Opt 001 only).	143
Required Equipment	143
Procedure	143
A2 DC Bias Output Resistor/Conductance Adjustment (Opt 001 only)	144
Required Equipment	144
Procedure	144
Writing the Instrument ID	146
Required Equipment	146

Procedure	146
How to confirm the E4991A option installed	146
System Backup (for serial prefix JP1KH, JP2KH, and MY432)	147
How to make a system backup disk	147
System backup Procedure	147

4. Troubleshooting

Introduction	152
How to exit from the E4991A Measurement View	153
To Troubleshoot the Instrument	154
Primary Trouble Isolation	154
No Display Troubleshooting	156
Booting Process Troubleshooting (for serial prefix JP1KH, JP2KH, and MY432)	159
Booting Process Troubleshooting (for serial prefix MY433 and later)	166
Troubleshooting Using Internal Test	170
Power On Self Test	170
PLL unlock	170
To Execute the Internal Test	170
Internal Test	170
Analog Test Failure Troubleshooting in the Internal Test	171
System Test Failure Troubleshooting in the Internal Test	172
Function Depend Troubleshooting	173
Functions	173
To check the Front Panel	177
To check the LCD	177
To check the External Keyboard	177
To check the Mouse	178
To check the FDD	178
To check the VGA Display Output	178
To check the External Trigger Input	179
To check the LAN (for serial prefix JP1KH, JP2KH, and MY432)	179
To Check the LAN (for serial prefix MY433 and later)	182
To check the Printer Parallel port (for serial prefix JP1KH, JP2KH, and MY432)	186
To check the Printer USB port (for serial prefix MY433 and later)	186
To check the GPIB	186
External Tests Failure Troubleshooting	187
To Execute the External Test	187
The contents of the external test	187
Front Keyboard & LCD Display Test	188
Source Test	188
Out ATT Test	189
Input ATT Test	189
IF Gain Test	190
Front Isolation Test	190
Test Head Test	191
DC Bias Test (Option 001 only)	191
Z Meas Test	192
External Test Failure Troubleshooting	193
Performance Tests Failure Troubleshooting	194

Contents

Troubleshooting for Performance Test Failure	194
To Configure the A20 Digital Motherboard and BIOS (for serial prefix JP1KH, JP2KH, and MY432)	195
To Identify the Motherboard Used	195
Configure the Motherboard	196
To Confirm or Set the BIOS Options	198
To Configure the A20 Digital Motherboard and BIOS (for serial prefix MY433 and later)	208
To Identify the Motherboard Installed	208
Configure the Motherboard	208
Testing DRAM on the Motherboard	208
To Confirm or Set the BIOS Options	209
5. Theory of Operation	
Overall Instrument Operation	218
Digital Section	221
A20 Digital Motherboard (for serial prefix JP1KH, JP2KH, and MY432)	221
A20 Digital Motherboard (for serial prefix MY433 and later)	221
A21 Analog Interface Board	221
A22 Front Panel Keyboard	221
A24 GPIB Board	221
A25 LAN Interface Board (for serial prefix JP1KH, JP2KH, and MY432)	221
A26 Display Board	221
A27 Mass Storage Disk Drive	222
A28 FDD (Floppy Disk Drive)	222
A51 LCD (Liquid Crystal Display)	222
A52 Inverter Board	222
Analog Section	223
A1 Reference Oscillator Board	225
A3 Source Board	225
A4 Receiver Board	226
A6 Test Head Board(for the standard and Option 010)	227
A10 Analog Motherboard	227
A2 DC Bias Board (Option 001)	227
A5 Reference Oven Board (Option 1D5)	227
6. Replaceable Parts	
Ordering Information	230
Direct Mail Order System	230
Exchange Assemblies	231
Replaceable Parts List (for serial prefix JP1KH, JP2KH, and MY432)	232
Power Cables and Plug Configurations	232
Top View (Major Assembly)	232
Top View (Cables & Other Parts)	234
Top View (Miscellaneous Parts)	236
Top View (Under Power Supply)	238
Front View (Analog Boards and Semi Rigid Cables)	240
Front Panel	242
Front Panel (Back Side)	244
Rear View	245

Side View	246
Test Head	248
Option 007 Temperature Characteristic Test Kit	250
Test Head for Option 010	252
Mass Storage Disk Drive Assembly	253
Power Supply Assembly	254
Other Parts	254
Replaceable Parts List (for serial prefix MY433 and later)	256
Power Cables and Plug Configurations	256
Top View (Major Assembly)	256
Top View (Cables & Other Parts)	258
Top View (Miscellaneous Parts)	260
Top View (Under Power Supply)	262
Front View (Analog Boards and Semi Rigid Cables)	264
Front Panel	266
Front Panel (Back Side)	268
Rear View	269
Side View	270
Test Head	272
Option 007 Temperature Characteristic Test Kit	274
Test Head for Option 010	276
Floppy Disk Drive Assembly	277
Mass Storage Disk Drive Assembly	278
Power Supply Assembly	279
Other Parts	280

7. Replacement Procedure

Replacing an Assembly	282
Required Tools	283
Outer Cover Removal	284
Tools Required	284
Procedure	284
Front Panel Removal	285
Tools Required	285
Procedure	285
A50 Power Supply Assembly Removal (for serial prefix JP1KH, JP2KH, and MY432)	286
Tools Required	286
Procedure	286
A50 Power Supply Assembly Removal (for serial prefix MY433 and later)	287
Tools Required	287
Procedure	287
A27 Mass Storage Disk Drive Assembly Removal	288
Tools Required	288
Procedure	288
A28 FDD (Floppy Disk Drive) Removal	289
Tools Required	289
Procedure	289
A20 Digital Motherboard Removal (for serial prefix JP1KH, JP2KH, and MY432)	290
Tools Required	290

Contents

Procedure	290
A20 Digital Motherboard Removal (for serial prefix MY433 and later)	291
Tools Required	291
Procedure	291
CPU Replacement (for serial prefix JP1KH, JP2KH, and MY432)	292
Tools Required	292
Procedure	292
DIMM64MB Memory Module Replacement (for serial prefix JP1KH, JP2KH, and MY432)	294
Procedure	294
A1/A2(Opt.001)/A3/A4 Board Removal	294
Tools Required	294
Procedure	294
A5 Reference Oven Board(Opt.1D5) Removal	296
Tools Required	296
Procedure	296
A10 Analog Motherboard Removal	296
Tools Required	296
Procedure	296
A21 Analog Interface Board and EEPROM Removal	297
Tools Required	297
Procedure	297
A24 GPIB/A25 LAN Board Removal (for serial prefix JP1KH, JP2KH, and MY432)	298
Tools Required	298
Procedure	298
A24 GPIB Card Replacement (for serial prefix MY433 and later)	299
Tools Required	299
Removal Procedure	299
Replacement Procedure	300
A26 Display Board Removal	301
Tools Required	301
Procedure	301
A22 Front Panel Keyboard Removal	302
Tools Required	302
Procedure	302
A51 LCD Removal	303
Tools Required	303
Procedure	303
A52 Inverter Board Removal	303
Tools Required	303
Procedure	303
8. Post-Repair Procedures	
Post-Repair Procedures	306
A. Manual Changes	
Manual Changes	310
B. System Installation for A27 Mass Storage	

System Recovery (for serial prefix JP1KH, JP2KH, and MY432)	312
Notes on executing system recovery	312
Procedure to execute system recovery (for serial number JP1KH and A27 that has never been replaced) 313	
Procedure to execute system recovery (for serial number other than JP1KH or A27 that has been replaced) 315	
System Recovery (for serial prefix MY433 and later)	317
Notes on executing system recovery	317
Procedure to execute system recovery (for serial prefix MY433 and later)	317
Initial Registration of E4991A (for serial prefix MY433 and later)	321
C. Firmware Update	
Firmware Update	326
Required Equipment	326
How to make the E4991A Firmware Installation Disk	326
How to update the E4991A firmware	327
D. Power Requirement	
Preparation for Power Supply	332
Power Requirements	332
Power Cable	332
Turning the Power ON and OFF	334
Turning the power ON	334
Turning the power OFF	334
E. Messages	
Alphabetical Order	336
A	336
B	336
C	336
D	338
E	338
F	339
G	339
I	339
M	341
N	341
O	343
P	343
Q	344
R	345
S	345
T	346
U	346
Messages indicating the internal status of the equipment	348
Messages indicating measurement failure	348
Messages indicating the results (or current status) of processing	349

1 General Information

The Service Manual is a guide to servicing the E4991A RF Impedance/Material Analyzer. The manual contains information requisite to do performance test, adjust, troubleshoot, and repair.

Organization of Service Manual

Tabs are used to divide the major chapter and appendix of this manual. The contents of each chapter and appendix in this manual as follows;

Chapter 1, “General Information,”

The Service Manual is a guide to servicing the E4991A RF Impedance/Material Analyzer. The manual contains information requisite to do performance test, adjust, troubleshoot, and repair.

Chapter 2, “Performance Test and Function Test,”

This chapter provides information on how to verify the E4991A performance. The maintenance consists of performance test and function test.

Chapter 3, “Adjustment,”

This chapter provides the adjustment procedure for the E4991A RF Impedance/Material Analyzer to ensure that the E4991A is within its specifications.

Chapter 4, “Troubleshooting,”

This chapter provides procedure to isolate the failure assembly in the E4991A RF Impedance/Material Analyzer.

Chapter 5, “Theory of Operation,”

This chapter provides the theory of operation of the E4991A RF Impedance/Material Analyzer.

Chapter 6, “Replaceable Parts,”

This chapter contains information for ordering replacement parts for the E4991A RF Impedance/Material Analyzer.

Chapter 7, “Replacement Procedure,”

This chapter provides procedure for removing and replacing the major assemblies in the E4991A RF Impedance/Material Analyzer.

Chapter 8, “Post-Repair Procedures,”

This chapter lists the procedures required to verify the E4991A operation after an assembly is replaced with a new one.

Appendix A, “Manual Changes,”

This appendix contains the information required to adapt this manual to versions or configurations of the E4991A manufactured earlier than the current printing date of this manual. The information in this manual applies directly to E4991A units with the serial number that is printed on the title page of this manual.

Appendix B, “System Installation for A27 Mass Storage,”

This appendix describes how to install the operation system (Windows 98) to the A27 mass storage. When the operating system in the A27 mass storage has damage, you can recover it before replacing the A27 by the following procedure.

Appendix C, “Firmware Update,”

This appendix describes how to update the E4991A firmware. When you want to update the E4991A firmware, refer to this appendix.

Appendix D, “Power Requirement,”

Appendix E, “Messages,”

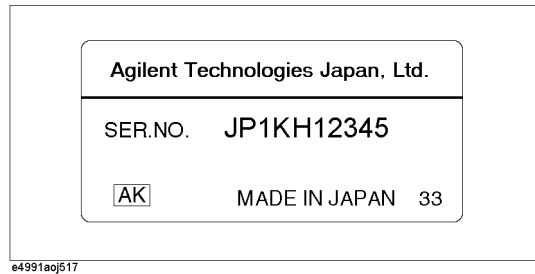
The E4991A can display error messages as well as messages that indicate the internal operating status of the equipment. This appendix explains what these messages mean by listing them in alphabetical order.

Instrument Covered by This Manual

Agilent Technologies uses a two-part, ten-character serial number label (See Figure 1-1) attached to the instrument's rear panel. The first five characters are the serial prefix and the last five digits are the suffix.

Figure 1-1

Serial Number Label Example



An instrument manufactured after the printing date of this manual may have serial number prefix that is not listed on the title page. This unlisted serial number prefix indicates the instrument is different from those described in this manual. The manual for this new instrument may be accompanied by a yellow Manual Changes supplement or have a different manual part number. This sheet contains “change information” that explains how to adapt the manual to the newer instrument.

In addition to change information, the supplement may contain information for correcting errors (Errata) in the manual. To keep this manual as current and accurate as possible, Agilent Technologies recommends that you periodically request the latest Manual Changes supplement. The supplement for this manual is identified by this manual's printing data and is available from Agilent Technologies. If the serial prefix or number of an instrument is lower than that on the title page of this manual, see Appendix A, Manual Changes. For information concerning, a serial number prefix that is not listed on the title page or in the Manual change supplement, contact the nearest Agilent Technologies office.

Required Equipment

Table lists the recommended equipment for performing maintenance on the E4991A.

Table 1-1 Recommended Test Equipment

Equipment	Critical specifications	Recommended Model	Qty.	Use ^{*1}
Frequency Counter	Frequency: 1 MHz to 3 GHz Accuracy: < 2.5 ppm	53131/2A Opt.010 & 030 ^{*2} or 53181A Opt.010 & 030 ^{*2}	1	P,A
Frequency Standard	Frequency: 10 MHz, Time Base Error: $\leq \pm 1 \times 10^{-10}$ /year	5071A or 5061B	1	A
Multimeter	No substitute	3458A	1	P,A
Power Meter	No Substitute	438A ^{*3} , E4418A/B or E4419A/B	1	P,A
Power Sensor	Frequency Range: 1 MHz to 3 GHz Power: -35 dBm to 1 dBm	8482A+8481D ^{*4} , E4412A ^{*5} or E9304A ^{*6}	1	P,A
Network Analyzer	Frequency: 5 GHz to 6 GHz	8753ES Opt.006, 8753ET Opt.006 or 8753E Opt.006	1	F
Performance Test Kit	No Substitute	16190B or 16190A Opt.001	1	P
Calibration Kit	No Substitute	16195B ^{*7} 85031B	1 1	P,A,F,T F
Test Head Stand(for Opt.010)	No Substitute	p/n E4991-65002	1	P
Termination	No Substitute	HP 909C Opt.012	1	T
Cable	BNC(m)-BNC(m) Cable, 61 cm BNC(m)-BNC(m) Cable, 122 cm N(m)-N(m) Cable, 61 cm	p/n 8120-1839 p/n 8120-1840 11500B	1 1 1	P,A A T

General Information
Required Equipment

Table 1-1 Recommended Test Equipment

Equipment	Critical specifications	Recommended Model	Qty.	Use ^{*1}
Adapter	N(m)-BNC(f) Adapter	p/n 1250-0780	1	P,A
	7mm-N(f) Adapter	11524A	1	P,A
	7mm-N(m) Adapter	11525A	1	A
	Dual Banana - BNC Adapter	1251-2277	1	P,A
	Coaxial Termination Feed Thru	11048C	1	P
Torque Wrench	Size: 3/4 inch Torque: 136 N-cm	p/n 8710-1766	1	P

*1. P: Performance Tests, F: Function Tests, A: Adjustment, T: Troubleshooting

*2. Opt.050 and Opt.124 can be substituted for Opt.030. In this case, a N(m)-BNC(f) adapter is necessary.

*3. 438A cannot be used with E4412A or E9304A.

*4. 8481D is not necessary for Adjustment.

*5. E4412A is not necessary for Adjustment.

*6. If E9304A is used, the multimeter is not necessary.

*7. 16195B is a furnished accessory for the E4991A.

2 Performance Test and Function Test

This chapter provides information on how to verify the E4991A performance. The maintenance consists of performance test and function test.

Required Equipment

The required test equipment for the performance test and the function test is listed on Table on page 19. Use only calibrated equipment when doing the performance test or the function test for the E4991A.

NOTE

The followings are indispensable to do the performance test. The service center must receive the following from the customer.

- Agilent E4991A
- 16195B 7-mm Calibration Kit (Furnished Accessory for E4991A)
- Standard Test Head (Furnished Accessory for E4991A)
- Option 007 Temperature Characteristic Test Kit (if the E4991A has Option 007)

If the E4991A has the Option 007 Temperature Characteristic Test Kit, you have to do the performance tests for the Option 007 (using the Option 007 kit) in addition to all the performance tests for standard E4991A.


- Option 010 Test Head including 1 m extension cable (if the E4991A has Option 010)

If the E4991A has the Option 010 Probe Station Connection Kit, you have to do the performance tests for the Option 010 (using the Option 010 Test Head) in addition to all the performance tests for standard E4991A.

How to Set the E4991A for Maintenance

This section provides procedure to set the E4991A in the performance test and function test.


This contains a set of keys that are used to move the cursor across the display or enter numeric values.

 (rotary knob)

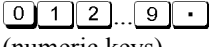
By turning the knob clockwise or counterclockwise, you can move the onscreen setting cursor. If you press this knob with the cursor placed over a feature, it is selected and executed.

 key
(arrow keys)

Used to move the onscreen setting cursor up, down, left, or right.

 key
(click key)

By pressing this key, you can select and execute the feature that the cursor is placed over. It has the same function as pressing the rotary knob.


 key
(numeric keys)



Used to type numeric values, one by one, in the cursor position. By pressing a unit key after entering a value, the value and unit are set and executed.

 key

When you press this key in an area where numeric values are typed, the character to the left of the cursor (|) is deleted. If two or more characters are currently selected (i.e., highlighted) with the cursor, pressing this key clears all of them.


If the numeric entry area contains no characters, input and deletion of '-' repeats each time you press this key.

 key
(unit keys)

By pressing one of these keys after entering a numeric value with the numeric keys, the entry is set and executed with the prefix indicating unit of measurement added to the value. Two unit prefixes are labeled on each key except ; however, the appropriate unit is determined automatically depending on the parameter being set. If you press the  key, the entered value is executed without a unit prefix.

 key

Used to close the setup toolbar at the right of the display. Also, by pressing this key when a dialog box is onscreen, you can cancel any entry mode and the box closes (i.e., this key can be used instead of pressing the **Cancel** or **x** button in a dialog box).

 key

When you press this key when a dialog box is onscreen, the entered setting is executed and the box closes. This key can also be used instead of pressing the **OK** button in a dialog box.

Performance Test and Function Test

How to Set the E4991A for Maintenance

Menu key

By pressing this key, the leftmost menu opens in the menu bar at the top of the display. Then, the arrow keys



can be used to move the cursor to other menus or to the desired item in a menu. Pressing the click key (**Click**) selects and executes the item. The **Menu** key is used to work with the menu bar when a mouse is not available.

To close an open menu, press the **Menu** key again.

Performance Test

Introduction

This section provides the test procedures used to verify that the E4991A meets its specifications. The performance tests can also be used for incoming inspection, and for verification after troubleshooting or adjustment. If the performance tests indicate that the E4991A is *NOT* operating within the specified limits, check your test setup, then proceed to troubleshooting if necessary.

Warm Up Time

Allow the E4991A to warm up for at least 30 minutes before you execute any of the performance tests

Ambient Conditions

Perform all performance tests in ambient conditions of $23\text{ }^{\circ}\text{C} \pm 5\text{ }^{\circ}\text{C}$, $\leq 70\%$ RH.

Performance Test Interval

The performance test should be performed periodically. The recommended test interval is 12 months.

NOTE

The test interval depends on maintenance of use and the environmental conditions under which the instrument is used. You may find that the test interval could be shortened or lengthened; however, such a decision should be based on substantial quantitative data.

Performance Test Record and Calculation Sheet

Performance test record lists all test points, acceptable test limits, test result entry columns, and measurement uncertainties. The listed measurement uncertainties are valid only when the recommended test equipment is used.

The calculation sheet is used as an aid for recording raw measurement data, and for calculating the performance test results.

The procedure for using the calculation sheet and performance test record is;

1. Photo copy the calculation sheet.
2. Follow the performance test procedure and record the measurement values, the E4991A's reading, etc., into the specified column on the calculation sheet.
3. Calculate the test result using the appropriate equation given on the calculation sheet, and record the test result into the Test Result column of the performance test record.

Frequency Accuracy Test

This test verifies the E4991A's test signal frequency accuracy with an external frequency counter.

Specification

Frequency Accuracy: ± 10 ppm (without Option 1D5)
 ± 1 ppm (with Option 1D5)

Required Equipment

Description	Recommended Model
Frequency Counter	53131/2A Opt.010 and 030 ^{*1} or 53181A Opt.010 and 030 ^{*1}
BNC(m)-BNC(m) Cable, 61 cm	p/n 8120-1839
N(m)-BNC(f) Adapter	p/n 1250-0780
7mm-N(f) Adapter	11524A

*1. Opt.050 and Opt.124 can be substituted for Opt.030. In this case, a N(m)-BNC(f) adapter is necessary.

Procedure

NOTE

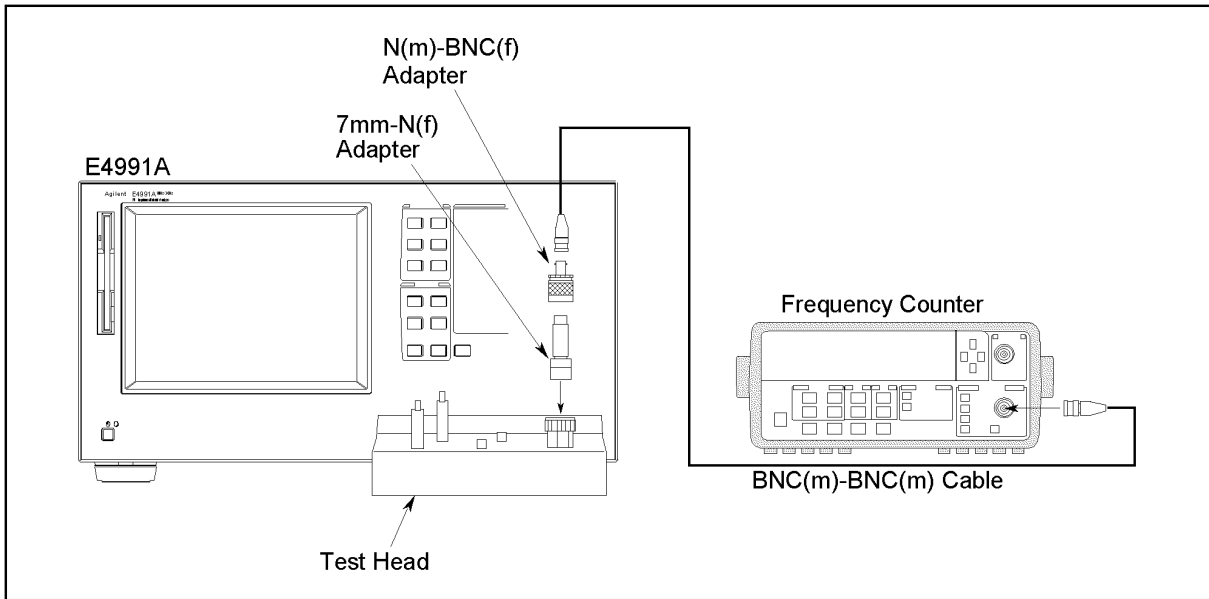
In the following procedure, the 53181A is used. Perform the same operation if another frequency counter is used.

1. Connect the equipment as shown in Figure 2-1. For testing the analyzer equipped with Option 1D5, connect a BNC(m)-BNC(m) cable between the Ext Ref In connector and the Ref Oven(Option 1D5) connector on the analyzer rear panel.

NOTE

For testing without Option 1D5, disconnect the above BNC(m)-BNC(m) cable.

Figure 2-1 Frequency Accuracy Test Setup 1



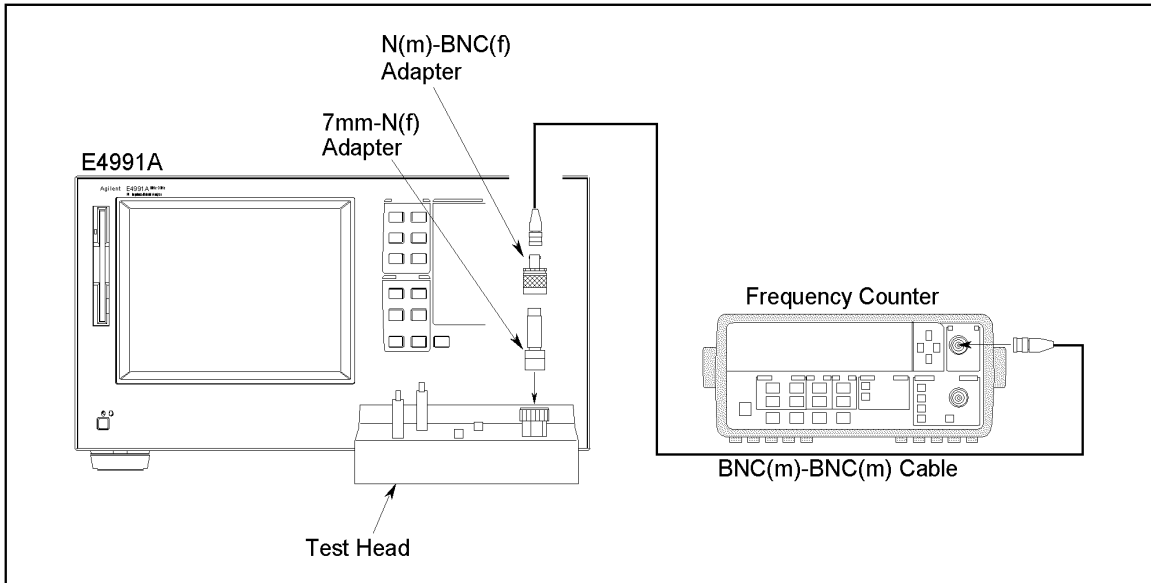
e4991ase001

2. Press **[Preset]** to preset the E4991A.
3. Set the E4991A as follows;

Setting	Operation
Frequency: 1MHz	[start/stop] - Center- [1]-[M/u]
Power: 0dBm	[Source] - Osc Unit- Power [Source] - Osc Level- [0]-[Enter]

4. Press **[Stop/Single]** on the 53181A front panel to make a single measurement.
5. Subtract the analyzer setting(1 MHz) from the frequency counter reading, and record the result on the performance test record.
6. Disconnect the BNC connector from 1 ch in the 53181A front panel, then connect it to the 2 ch as shown in Figure 2-2.

Figure 2-2 Frequency Accuracy Test Setup 2



e4991ase002

7. Set the E4991A's frequency to 3GHz by the following procedure.
[start/stop] - Center - [3]-[G/n]
8. Press **[Stop/Single]** on the 53181A front panel to make a single measurement.
9. Subtract the analyzer setting (3 GHz) from the frequency counter reading, and record the result on the performance test record.

Power Level Accuracy Test

This test verifies the E4991A's test signal power level accuracy with a power meter and a power sensor.

Specification

Power Level Accuracy:	± 2 dB @ ≤ 1 GHz
	+2 dB/-4 dB @ ≤ 1 GHz (with Opt. 007)
	± 5.5 dB @ ≤ 1 GHz (with Opt. 010)
	± 3 dB @ > 1 GHz
	+3 dB/-6 dB @ > 1 GHz (with Opt. 007)
	± 7.6 dB @ > 1 GHz (with Opt.010)

Required Equipment

Description	Recommended Model
Power Meter	E4418A/B, E4419A/B or 438A
Power Sensor	E4412A, E9304A or 8482A+8481D
Multimeter	3458A
BNC(m)-BNC(m) Cable, 61 cm	p/n 8120-1839
N(m)-BNC(f) Adapter	p/n 1250-0780
7mm-N(f) Adapter	11524A
Dual Banana-BNC(f) Adapter	p/n 1251-2277
Feed Through Termination	11048C

Procedure

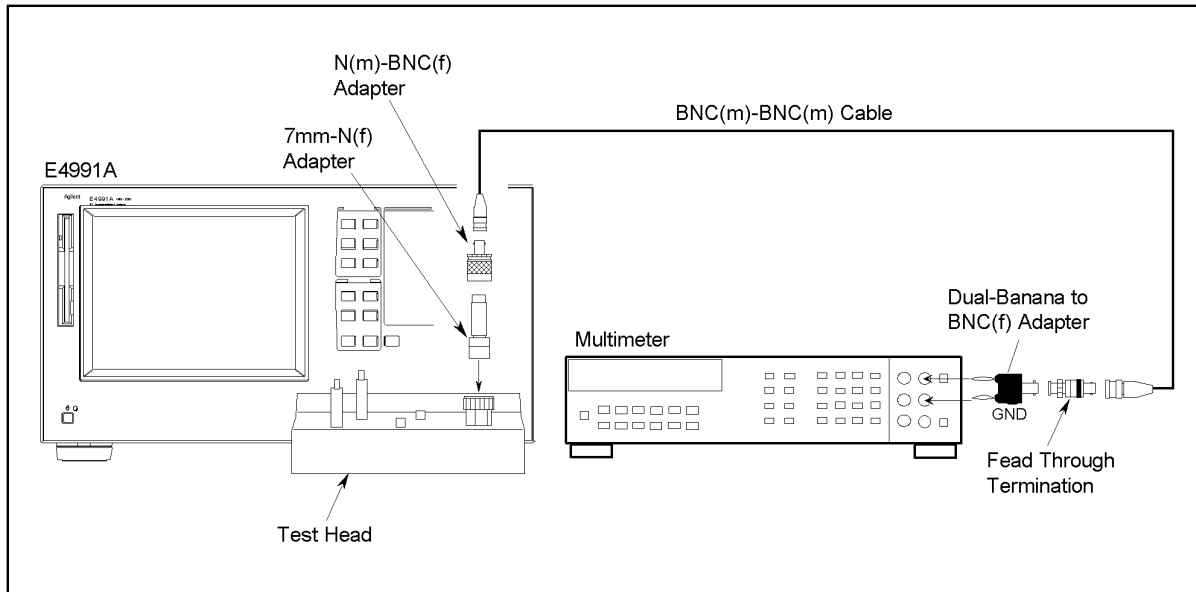
1. Connect the equipment as shown in Figure 2-3.

NOTE

Refer to Page 42 for the test setup applied to Option 007 and, Page 44 for Option 010.

Performance Test and Function Test
Performance Test

Figure 2-3 Power Level Accuracy Test Setup 1



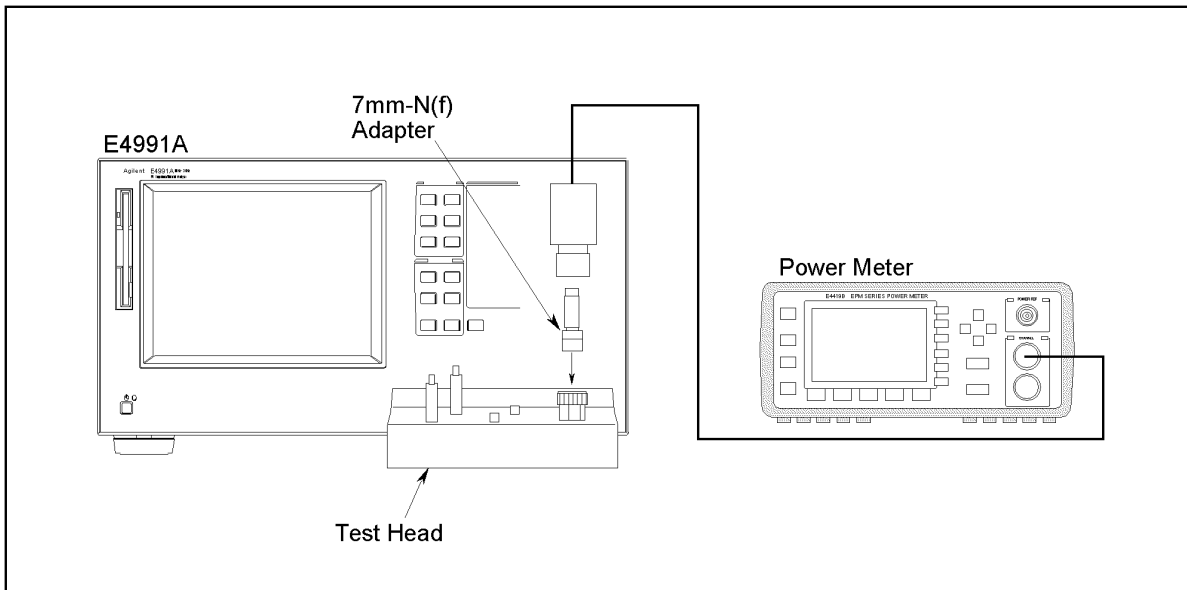
e4991ase032

2. Press **[Preset]** to preset the E4991A.
3. Set the E4991A as follows;

Setting	Operation
Frequency: 1MHz	[start/stop] - Center- [1]-[M/u]
Power: -15 dBm	[Source] - Osc Unit- Power [Source] - Osc Level- [+/-]-[1]-[5]-[Enter]

4. Press **[Trigger Setup]**.
5. Select **Trigger Source-Manual**.
6. Press **[Reset]** key (**[blue] - [->]**) to initialize the 3458A, then Set it as follows;
 - a. Press **[ACV]** to set the measurement mode to AC voltage.
 - b. Press **[S]([blue] - [N Rdgs/Trig])**, \downarrow , \downarrow , \downarrow to display SETACV.
 - c. Press \Rightarrow , \downarrow , \downarrow , \downarrow to display SYNC, then press **[Enter]**
 - d. Press **[NPLC] - [1] - [0] - [0] - [Enter]**
7. Press **[Trigger]** to make a measurement.
8. Record the multimeter reading to the calculation sheet.
9. Calculate the test result according to the calculation sheet, then record it to the performance test record.
10. Perform zeroing and calibrating the power meter
11. Connect the equipment as shown in Figure 2-4.

Figure 2-4 Power level Accuracy Test Setup 2



e4991ase005

2. Performance Test and
 Function Test

12. Set the E4991A as follows;

Setting	Operation
Frequency: 1GHz	[start/stop] - Center- [1]-[G/n]
Power: 1dBm	[Source] - Osc Unit- Power [Source] - Osc Level- [1]-[Enter]

13. Input the E4991A's frequency to the power meter.

14. Press **[Trigger]** to make a measurement.

15. Subtract the E4991A's reading from the power meter reading, then record it to the performance test record.

16. Set the OSC level and Frequency settings as shown in Table 2-1 to test the analyzer and repeat step 12 to 15 for other points.

Table 2-1 **Power Level Accuracy Test Settings**

OSC Level	Center Frequency
1 dBm	1 GHz
0 dBm	3 GHz
-7.9 dBm	3 GHz
-10 dBm	300 MHz
-20 dBm	50 MHz
-25 dBm	1 GHz
-30 dBm	10 MHz
-35 dBm	2 GHz
-40 dBm	100 MHz

Impedance Measurement Accuracy Test

This test verifies the E4991A's impedance measurement accuracy with a calibrated standards(16190B).

Specification

Basic Accuracy: $\pm 0.65\%$

NOTE

See the “Specifications and Supplemental Performance Characteristics” of the Operation Manual.

Required Equipment

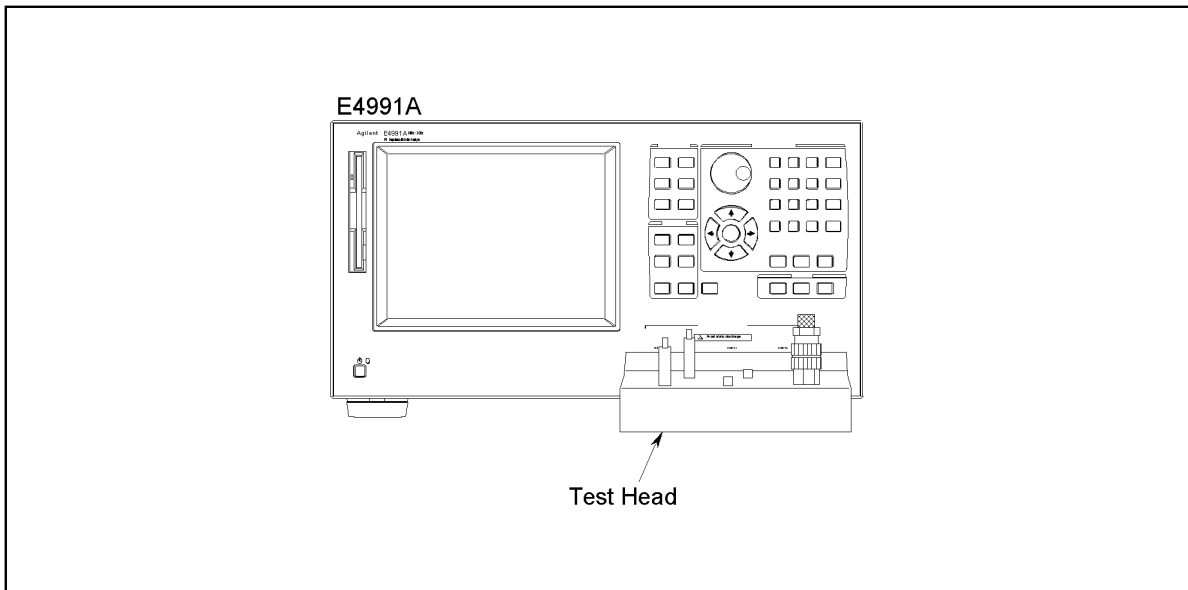
Description	Recommended Model
Performance Test Kit	16190B
Calibration Kit	16195B(furnished with E4991A)

Procedure

Preparation

1. Connect the equipment as shown in Figure 2-5.

Figure 2-5 Impedance Measurement Accuracy Test



e4991ase006

2. Press **[Preset]** to preset the E4991A.
3. Press **[Sweep]**.
4. Press **Segment Table Menu** to show segment table.
5. Set the measurement points using Add Segment as Figure 2-6.

Figure 2-6

Segment Table 1(Power Level: -3 dBm, Averaging: 8)

Trace 1 - E4991A RF Impedance/Material Analyzer - [E4991A1:2]							
Trace Meas/Format Scale Display Marker Stimulus Trigger Utility Save/Recall System							
No	Start [Hz]	Stop [Hz]	Nop	Avg	Osc [dBm]	Bias Lvl [A]	Bias Lmt [V]
1	1 M	10 M	2	8	-3.0000	100.00 u	1.0000
2	100 M	200 M	2	8	-3.0000	100.00 u	1.0000
3	300 M	500 M	2	8	-3.0000	100.00 u	1.0000
4	600 M	800 M	2	8	-3.0000	100.00 u	1.0000
5	1 G	1.3 G	2	8	-3.0000	100.00 u	1.0000
6	1.6 G	1.8 G	2	8	-3.0000	100.00 u	1.0000
7	2 G	2.2 G	2	8	-3.0000	100.00 u	1.0000
8	2.4 G	2.6 G	2	8	-3.0000	100.00 u	1.0000
9	2.8 G	3 G	2	8	-3.0000	100.00 u	1.0000
10							
11							
12							
13							
14							
15							
16							

Segment Table:

Add Segment

Segment No.

Start Hz

Stop Hz

Number Of Points:

Point Average:

Delete Segment

More

Ready Bias OFF Uncal Comp OFF Avg 1 ExtRef

6. Press **[Sweep]**.
7. Press **Sweep Type-Segment** to use segment table.
8. Press **[Trigger Setup]**.
9. Select **Trigger Source-Manual**.
10. Press **[Cal/Compen]** to show the Cal/Compen menu.
11. Select **Cal Menu[Uncal]**.
12. Select **Cal Type-User Freq & Pwr**.
13. Connect the OPEN Termination included in the 16195B to the 7 mm connector using the Torque Wrench(p/n:8710-1760).
14. Select **Meas Open** to calibrate open termination.
15. Connect the SHORT Termination included in the 16195B to the 7 mm connector using the Torque Wrench(p/n:8710-1760).
16. Select **Meas Short** to calibrate short termination.
17. Connect the 50 Ω Termination included in the 16195B to the 7 mm connector using the Torque Wrench(p/n:8710-1760).
18. Select **Meas Load** to calibrate 50 Ω termination.
19. Select **Done**.
20. Press **[Save/Recall]** to show the Save/Recall softkey menu.
21. Select **Save State**.
22. Press **[-],[3],[Enter]**, then E4991A's status is saved to "-3.sta" status file.
23. Set Osc[dBm] to -20 and Avg to 1 for all measurement points as Figure 2-7.

Figure 2-7

Segment Table 2 (Power Level: -20dBm, Averaging: 1)

No	Start [Hz]	Stop [Hz]	Nop	Avg	Osc [dBm]	Bias Lvl [A]	Bias Lmt [V]
1	1 M	10 M	2	1	-20.000	100.00 u	1.0000
2	100 M	200 M	2	1	-20.000	100.00 u	1.0000
3	300 M	500 M	2	1	-20.000	100.00 u	1.0000
4	600 M	800 M	2	1	-20.000	100.00 u	1.0000
5	1 G	1.3 G	2	1	-20.000	100.00 u	1.0000
6	1.6 G	1.8 G	2	1	-20.000	100.00 u	1.0000
7	2 G	2.2 G	2	1	-20.000	100.00 u	1.0000
8	2.4 G	2.6 G	2	1	-20.000	100.00 u	1.0000
9	2.8 G	3 G	2	1	-20.000	100.00 u	1.0000
10							
11							
12							
13							
14							
15							
16							

24. Perform OPEN, SHORT, LOAD calibration as described in step 10 to 19.
25. Press **[Save/Recall]** to show the Save/Recall softkey menu.
26. Select **Save State**.
27. Press **[-],[2],[0][Enter]**, then E4991A's status is saved to "-20.sta" status file.
28. Set OSC[dBm] to -40 and Avg to 1 for all measurement point as Figure 2-8.

Figure 2-8

Segment Table 3 (Power Level: -40dBm, Averaging: 1)

No	Start [Hz]	Stop [Hz]	Nop	Avg	Osc [dBm]	Bias Lvl [A]	Bias Lmt [V]
1	1 M	10 M	2	1	-40.000	100.00 u	1.0000
2	100 M	200 M	2	1	-40.000	100.00 u	1.0000
3	300 M	500 M	2	1	-40.000	100.00 u	1.0000
4	600 M	800 M	2	1	-40.000	100.00 u	1.0000
5	1 G	1.3 G	2	1	-40.000	100.00 u	1.0000
6	1.6 G	1.8 G	2	1	-40.000	100.00 u	1.0000
7	2 G	2.2 G	2	1	-40.000	100.00 u	1.0000
8	2.4 G	2.6 G	2	1	-40.000	100.00 u	1.0000
9	2.8 G	3 G	2	1	-40.000	100.00 u	1.0000
10							
11							
12							
13							
14							
15							
16							

29. Perform OPEN, SHORT, LOAD calibration as described in step 10 to 19.

Performance Test and Function Test

Performance Test

30. Press **[Save/Recall]** to show the Save/Recall softkey menu.
31. Select **Save State**.
32. Press **[-],[4],[0],[Enter]**, then E4991A's status is saved to "-40.sta" status file.

OPEN Termination

33. Record the 16190B's OPEN termination calibration values on the calculation sheet.
34. Connect the 16190B's OPEN termination to the 7mm connector.
35. Press **[Save/Recall]** to show the Save/Recall softkey menu.
36. Select **Recall State**.
37. Select the file "-3.sta".
38. Press **[Meas/Format]** to show the parameter setup menu.
39. Select **Meas Parameter- |Y|**.
40. Press **[Trigger]** to make a measurement.
41. Record the |Y| readings to the calculation sheet.
42. Calculate the test result according to the calculation sheet, the record it to the performance test record.

SHORT Termination

43. Record the 16190B's SHORT termination calibration values on the calculation sheet.
44. Connect the 16190B's SHORT termination to the 7mm connector.
45. Press **[Meas/Format]** to show the parameter setup menu.
46. Select **Meas Parameter- |Z|**.
47. Press **[Trigger]** to make a measurement.
48. Record the |Z| readings to the calculation sheet.
49. Calculate the test result according to the calculation sheet, the record it to the performance test record.

50 Ω Termination

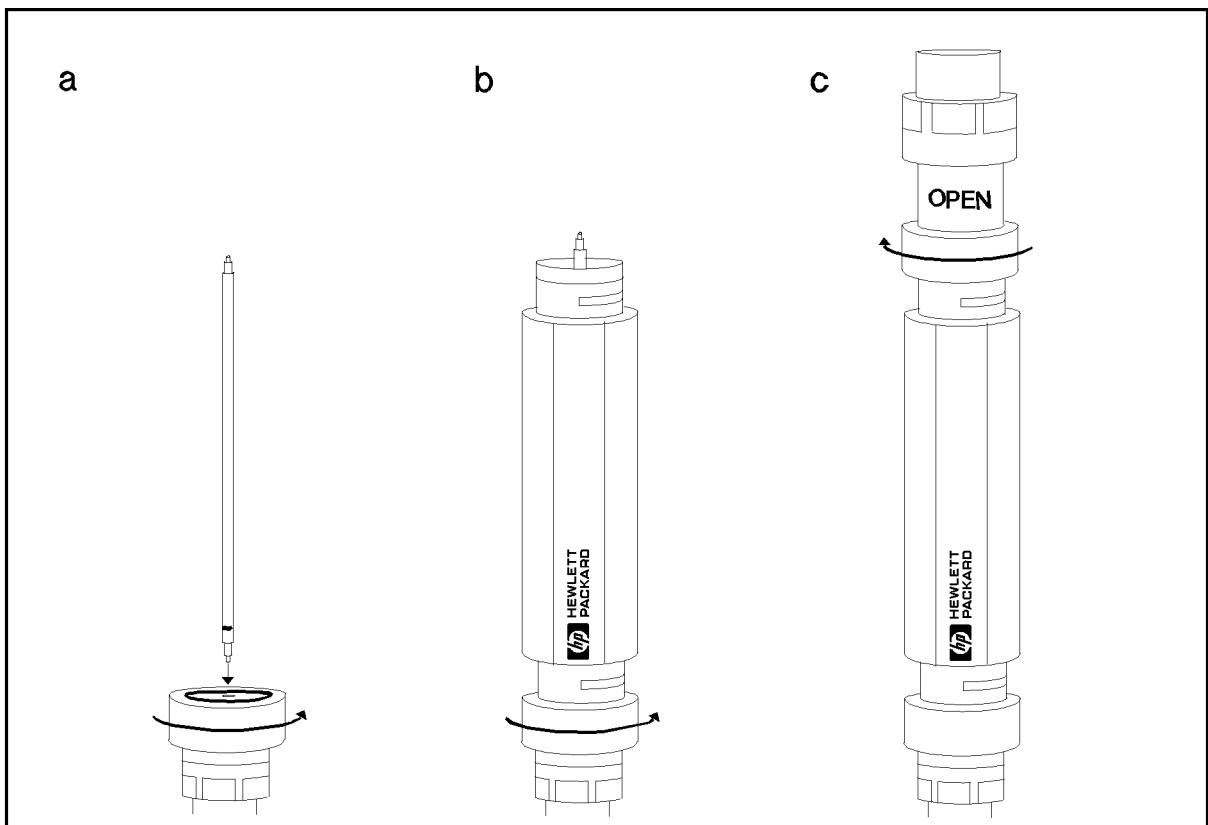
50. Record the 16190B's 50 Ω termination calibration values on the calculation sheet.
51. Connect the 16190B's 50 Ω termination to the 7mm connector.
52. Press **[Trigger]** to make a measurement.
53. Record the |Z| and θ readings to the calculation sheet.
54. Calculate the test result according to the calculation sheet, the record it to the performance test record.

10 cm airline with OPEN Termination

55. Record the 16190B's 10 cm airline with OPEN termination calibration values on the calculation sheet.
56. Connect the 16190B's 10 cm airline and OPEN termination to the 7mm connector, using the following procedure. (see Figure 2-9)

- a. Fully retract the threads on the 7mm connector. Then insert the marked side tip of the airline center conductor.
- b. Gently cover the airline center conductor with the airline outer conductor, with the logo side down. (To prevent damage, don't let the conductor scrape the edge of the outer conductor.) Mate the outer conductors. then torque the connection to 136 N-cm. (A 1/2 inch open end wrench may be necessary to hold the airline stationary.)
- c. Gently inserts the airline center conductor into the open termination center conductor. Mate the outer conductors. Then torque the connection to 136 N-cm using the Torque Wrench(p/n:8710-1760). A 1/2 inch open end wrench may be necessary to hold the airline stationary.

Figure 2-9 10 cm Airline with OPEN Measurement Test Setup



06S02005

57. Press **[Trigger]** to make a measurement.
58. Record the $|Z|$ and θ readings to the calculation sheet.

NOTE

Ignore the reading at 1.3 GHz and 2.8 GHz.

59. Press **[Save/Recall]** to show the Save/Recall menu.
60. Select **Recall State**.
61. Select the file “-20.sta”.
62. Press **[Trigger]** to make a measurement.

Performance Test and Function Test

Performance Test

63. Record the $|Z|$ and θ readings to the calculation sheet.

NOTE

Ignore the reading at 1.3 GHz and 2.8 GHz.

64. Calculate the test result according to the calculation sheet, the record it to the performance test record.

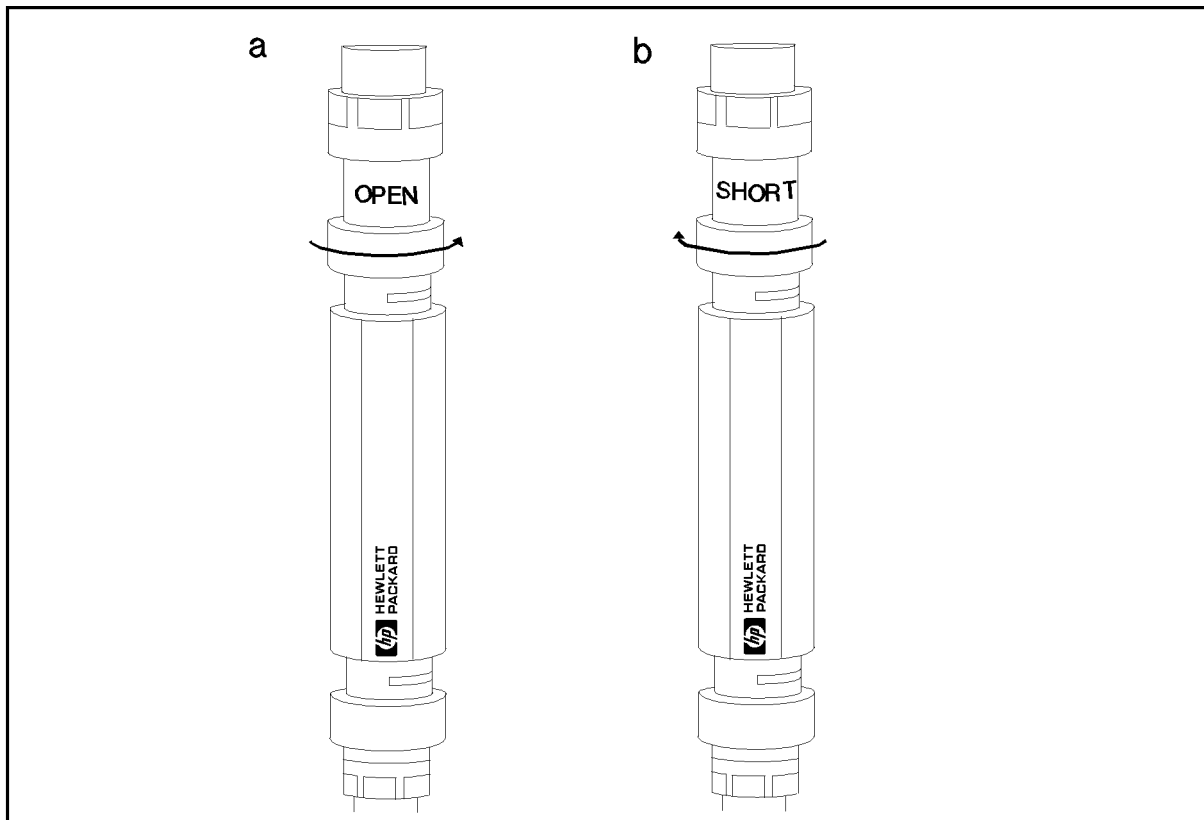
10 cm airline with SHORT Termination

65. Record the 16190B's 10 cm airline with SHORT termination calibration values on the calculation sheet.

66. Connect the 16190B's 10 cm airline and short termination to the 7mm connector, using the following procedure. (see Figure 2-10)

- a. Remove the open termination from the airline.
- b. Gently inserts the airline center conductor into the short termination center conductor. Mate the outer conductors. Then torque the connection to 136 N-cm using the Torque Wrench(p/n:8710-1760). A 1/2 inch open end wrench may be necessary to hold the airline stationary.

Figure 2-10 10 cm Airline with SHORT Measurement Test Setup



C6502006

67. Press **[Save/Recall]** to show the Save/Recall menu.

68. Select **Recall State**.

69. Select the file "0.sta".

70. Press **[Trigger]** to make a measurement.
71. Record the $|Z|$ and θ readings to the calculation sheet.

NOTE

Ignore the reading at 800 MHz, 2.2 GHz and 3.0 GHz.

72. Press **[Save/Recall]** to show the Save/Recall softkey menu.
73. Select **Recall State**.
74. Select the file “-40.sta”.
75. Press **[Trigger]** to make a measurement.
76. Record the $|Z|$ and θ readings to the calculation sheet.
77. Calculate the test result according to the calculation sheet, the record it to the performance test record.

NOTE

Ignore the reading at 800 MHz, 2.2 GHz and 3.0 GHz.

DC Bias Level Accuracy Test (Option 001)

This test verifies the E4991A's DC bias level accuracy at several level.

Specification

Voltage(open terminal)	$\pm(0.1\% + 6 \text{ mV})$
Current(short terminal)	$\pm(0.2\% + 20\mu\text{A})$

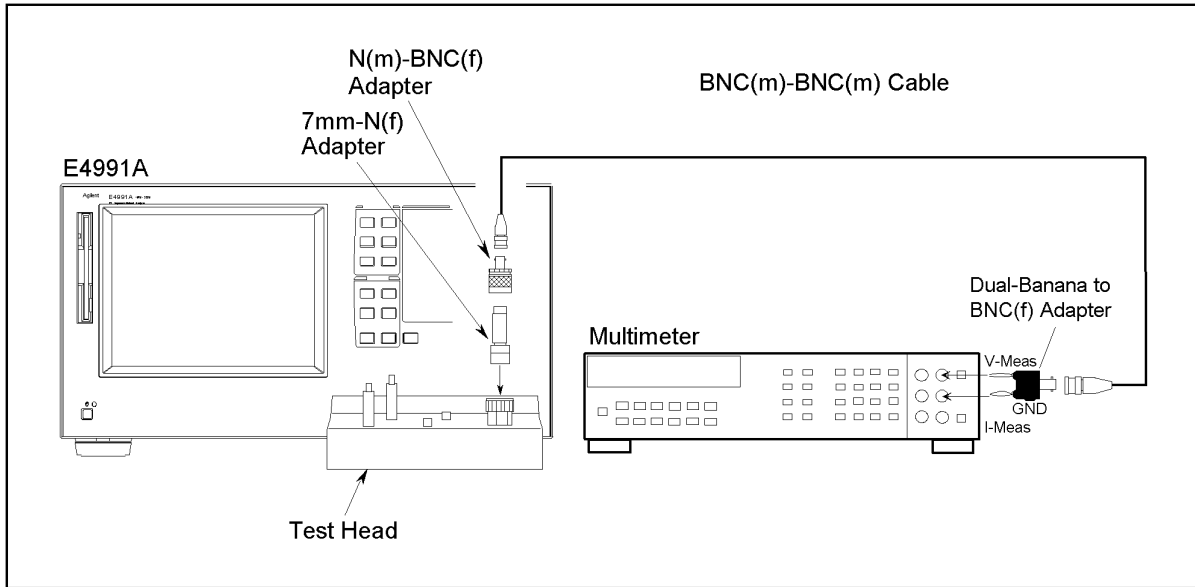
Required Equipment

Description	Recommended Model
Multimeter	3458A
BNC(m)-BNC(m) Cable, 61 cm	p/n 8120-1839
N(m)-BNC(f) Adapter	p/n 1250-0780
7mm-N(f) Adapter	11524A
Dual Banana-BNC(f) Adapter	p/n 1251-2277

Procedure

1. Connect the test equipment as shown in Figure 2-11. The BNC(f)-Banana adapter must be connected to voltage measurement connectors with the "GND" connector connecting to the "LO" terminal.

Figure 2-11 DC Bias Level Accuracy Test (voltage) Setup



e4991ase014

- Initialize the multimeter, then set the NPLC to 100 and DCV function.
- Press **[Preset]** to preset the E4991A, then set it as follows;

Setting	Operation
Osc Level: 0 V *1	[Source]- Osc Level-[0]-[Enter]
DC Bias: On	[Source]- DC Bias-On
Bias Source: Voltage	[Source]-Bias Source-Voltage
Bias Limit: 50 mA	[Source]-Bias Limit-[5]-[0]-[k/m]
Bias Level: -40 V	[Source]-Bias Level-[-]-[4]-[0]-[Enter]

*1. OSC level is set to 5 mV automatically.

- Press **[Trigger Setup]-Continuous**.
- Subtract the analyzer setting(-40V) from the multimeter reading, and record the result on the performance test record.
- Set the Bias Level to test the analyzer as shown in Table 2-2 and repeat Step 4 to 5 for other test points.

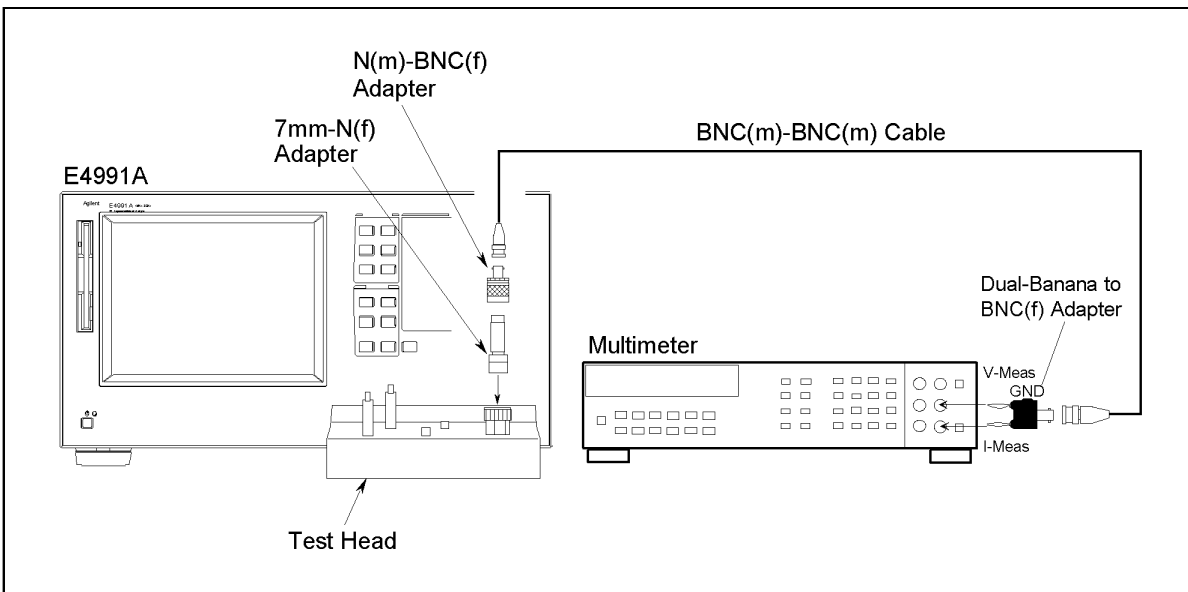
Table 2-2

DC Bias Level Accuracy Test (Voltage) Settings

Bias Voltage Setting
-40 V
-4 V
0 V
4 V
40 V

7. Connect the test equipment as shown in Figure 2-12. Connect the BNC(f)-Banana adapter to current measurement connectors with the “GND” connector connecting to the “LO” terminal.

Figure 2-12 DC Bias Level Accuracy Test (current) Setup



e4991ase013

8. Set the multimeter to DCI function.
9. Press **[Preset]** to preset the E4991A, then set it as follows;

Setting	Operation
Osc Level: 0 V *1	[Source] - Osc Level- [0] - [Enter]
DC Bias: On	[Source] - DC Bias-On
Bias Source: Current	[Source] -Bias Source-Current
Bias Limit: 40 V	[Source] -Bias Limit- [4] - [0] - [Enter]
Bias Level: -50 mA	[Source] -Bias Level- [] - [5] - [0] - [k/m]

*1. OSC level is set to 5 mV automatically.

10. Press **[Trigger Setup]**-Single for a single sweep measurement.
11. Record the multimeter reading on the performance test record.
12. Set the Bias Level to test the analyzer as shown in Table 2-3 and repeat Step 10 to 11 for other test points.

Table 2-3

DC Bias Level Accuracy Test (Current) Settings

Bias Voltage Setting
-50 mA
-4 mA
-100 μ A
100 μ A
4 mA
50 mA

Performance Test (for Option 007 Temperature Characteristic Test Kit)

Introduction

This section provides the information on the performance test setups and procedures for the E4991A Option 007 Temperature Characteristic Test Kit. To execute the performance tests for the Option 007, both the Temperature Characteristic Test Kit and the E4991A are required.

Required Test

The E4991A with Option 007 requires the following performance tests with the test setups for Option 007 to be done in addition to the performance tests for standard E4991A.

- Power Level Accuracy Test
- Impedance Measurement Accuracy Test

Specification

Except for the Power Level Accuracy and Impedance Measurement Accuracy, the E4991A Option 007 specifications are same as the standard E4991A specifications. The Power Level Accuracy and Impedance Measurement Accuracy of the Option 007 E4991A are described below:

Power Level Accuracy:	± 2 dB @ ≤ 1 GHz (without Opt. 007)
	+2 dB/-4 dB @ ≤ 1 GHz (with Opt. 007)
	± 3 dB @ > 1 GHz (without Opt. 007)
	+3 dB/-6 dB @ > 1 GHz (with Opt. 007)

Impedance Measurement Accuracy	The values of accuracy equation terms E_a , Z_s and Y_o for Option 007 are different from those of the standard E4991A. Refer to Specifications on Chapter 11 of the E4991A Operation Manual.
--------------------------------	---

Required Equipment

The required equipment for the Option 007 performance tests is same as that for the standard E4991A.

Test Procedure

- Step 1.** Perform all the necessary performance tests for the standard E4991A.
- Step 2.** Install the E4991A and the hardware of the Option 007 Temperature Characteristic Test Kit as shown in Figure 2-13. The installation procedure is as follows:
 - a. Attach the test head of the E4991A to the Test Head Stand (included in the kit).

- b. Mount the cable holder (attached to the 7-mm coaxial connector module of the Heat-Resistant Cable) on the Fixture Stand with its captive screws.
- c. Place the Fixture Stand on a box (a carton or a substitute) to level the Heat-Resistant Cable at the same height as the DUT Port on the test head. Adjust the height of the Fixture Stand for $223 \text{ mm} \pm 10 \text{ mm}$ with a spacer (another carton or books) inserted between the Fixture Stand and box as shown in the figure.
- d. Connect the 1 meter RF Extension Cable Assembly and Heat-Resistant Cable to the test head of the E4991A as shown in the figure.

CAUTION

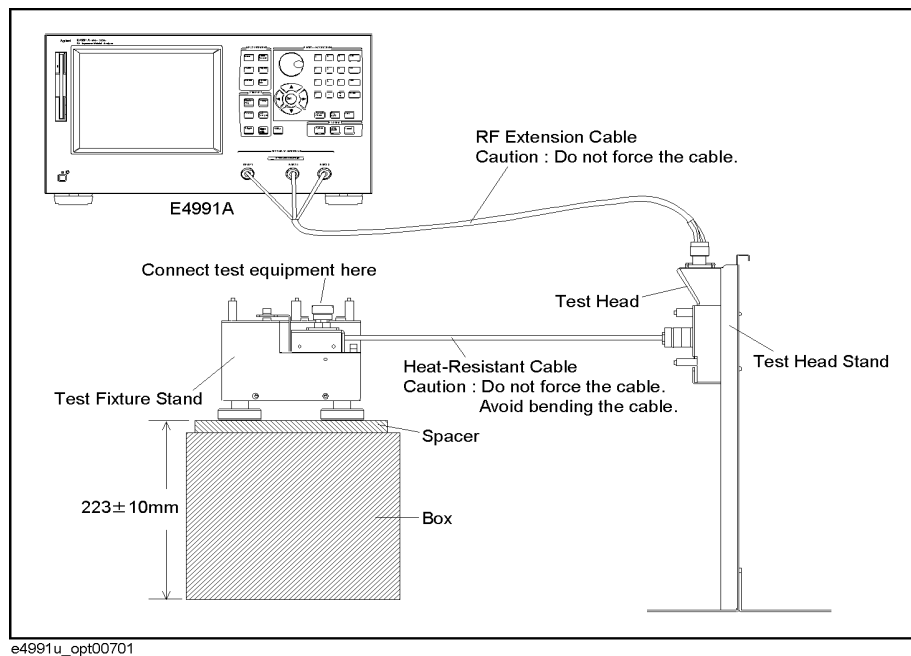
Do not force the RF extension cable assembly. It is strongly suggested that the RF extension cable assembly be connected last of the setup procedure in order to prevent the joint of SMA connectors on the cable from being forced and damaged.

CAUTION

Do not force the high temperature cable or else the cable may be impaired. Avoid bending the cable.

Figure 2-13

Option 007 Hardware Installation for Performance Tests



Step 3. Connect the test equipment to the 7-mm coaxial connector on the high temperature cable assembly in place of the DUT Port on the test head and, perform the following tests. See Figure 2-13 for the connector to which the test equipment (a power sensor, coaxial terminations or a 10 cm air-line) is connected.

- Power Level Accuracy Test
- Impedance Measurement Accuracy Test

NOTE

Record the test results using the performance test record for Option 007.

Performance Test (for Option 010 Probe Station Connection Kit)

Introduction

This section provides the information on the performance test setups and procedures for the E4991A Option 010 Probe Station Connection Kit. To execute the performance tests for the Option 010, both the test head for Option 010 and the E4991A are required.

Required Test

The E4991A with Option 010 requires the following performance tests with the test setups for Option 010 to be done in addition to the performance tests for standard E4991A.

- Frequency Accuracy Test
- Power Level Accuracy Test
- Impedance Measurement Accuracy Test
- DC Bias Level Accuracy Test (Opt. 001)

Specification

Except for the Power Level Accuracy, the E4991A Option 010 specifications are same as the standard E4991A specifications. Therefore, the Frequency Accuracy, Impedance Measurement Accuracy and DC Bias Level Accuracy of the E4991A with Option 010 are tested to the same test limits as the standard E4991A. The Power Level Accuracy specification of the Option 010 is different from that of the standard E4991A as follows:

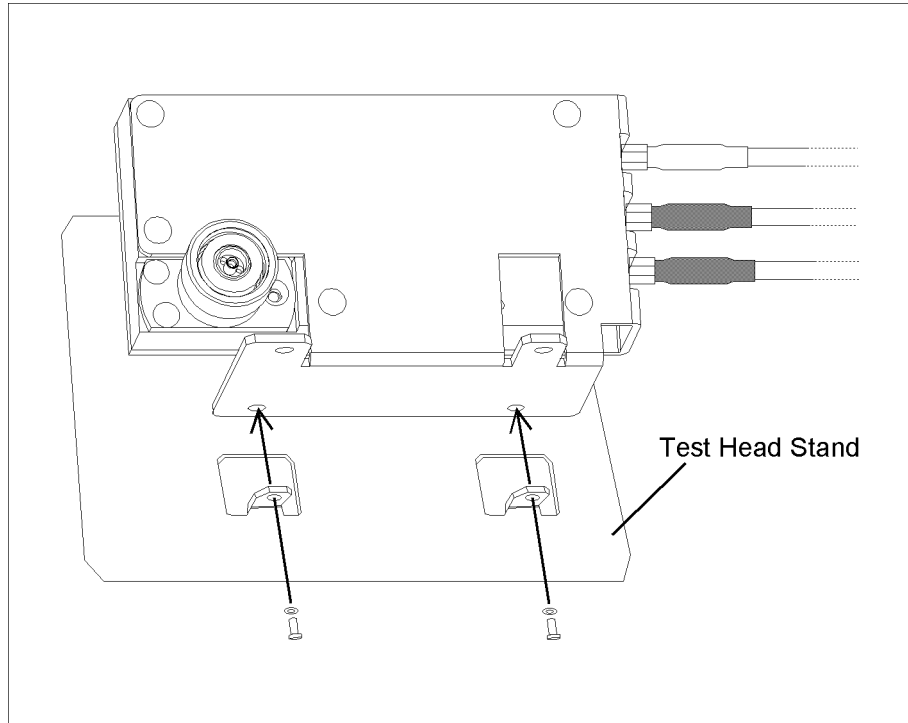
Power Level Accuracy:	± 2 dB @ ≤ 1 GHz (without Opt. 010)
	± 5.5 dB @ ≤ 1 GHz (with Opt. 010)
	± 3 dB @ > 1 GHz (without Opt. 010)
	± 7.6 dB @ > 1 GHz (with Opt. 010)

Required Equipment

The required equipment for each test of the Opt.010 test head is the same as that for the standard test head. Perform each test using the Opt.010 test head in place of the standard test head. Mount the Option 010 test head on the Test Head Stand (P/N:E4991-65002) with two screws and two washers as shown in Figure 2-14.

Figure 2-14

Test Head Stand for Opt.010 Test Head



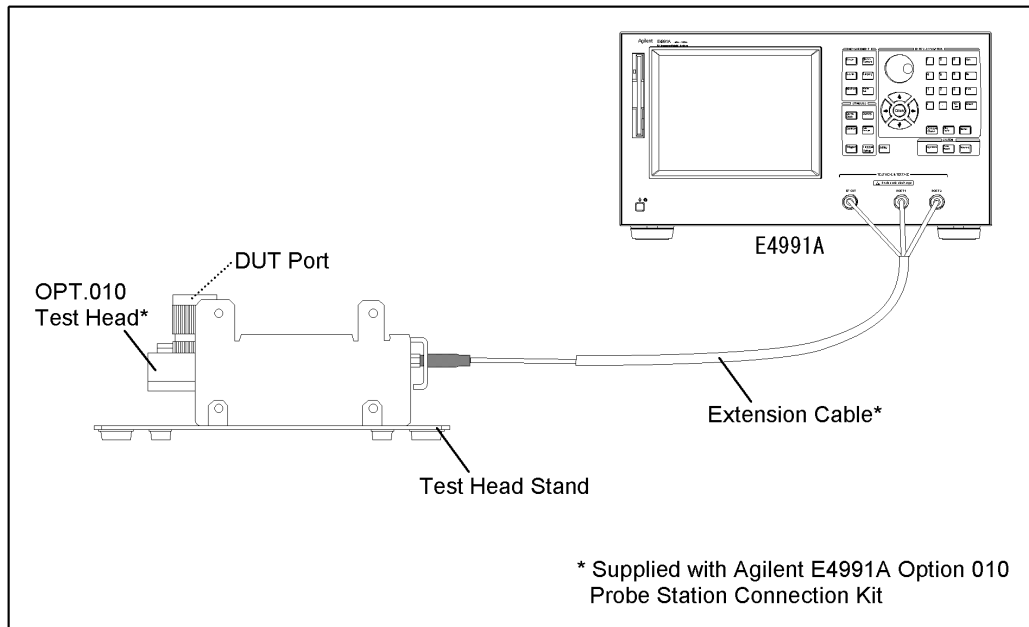
e4991ase129

Performance Test and Function Test
Performance Test (for Option 010 Probe Station Connection Kit)

Test Procedure

- Step 1.** Perform all the necessary tests using the standard test head.
- Step 2.** Perform all the necessary tests using the Option 010 test head. The each test procedure for Opt.010 test head is the same as that for the standard test head. Then, connect the equipment as shown in Figure 2-15.

Figure 2-15 **Equipment Setting for Opt.010 Test Head**



Function Test

Introduction

This section provides the test procedures used to verify that the E4991A's performance characteristics are met. The function tests is recommended to be performed with the E4991A performance test.

Warm Up Time

Allow the E4991A to warm up for at least 30 minutes before you execute any of the performance tests

Ambient Conditions

Perform all function tests in ambient conditions of $23\text{ }^{\circ}\text{C} \pm 5\text{ }^{\circ}\text{C}$, $\leq 70\%$ RH.

Low Loss Capacitor Check

This test verifies the Low Loss Capacitor included in the 16195B Calibration Kit which is furnished accessory for E4991A.

Required Equipment

Description	Recommended Model
Network Analyzer	8753ES Opt.006, 8753ET Opt.006 or 8753E Opt.006
7mm Calibration KIT	85031B

Procedure

1. Press **[Preset]** to preset the network analyzer.
2. Setup the network analyzer as follows;

Parameter Setting	Operation
Conversion: Z(reflection)	[Meas]-CONVERSION-Z:refl
Format: Liner	[Format]-LIN MAG
Source Power: 0 dBm	[Power]-[0]-[×1]
Start Frequency: 5 GHz	[Start]-[5]-[G/n]
Stop Frequency: 6 GHz	[Stop]-[6]-[G/n]
IF BW: ≤100 Hz	[Avg]-IF BW-[1]-[0]-[0]-[×1]
Number of points: 401 or larger	[Sweep Setup]-NUMBER of POINTS-[4]-[0]-[1]-[×1]

3. Perform the S11 1 port full calibration.
4. Connect the low loss capacitor to the port 1.
5. Make a single sweep measurement.
6. Record the minimum impedance value and its frequency to calculation sheet.
7. Record the test result to the function test record.

NOTE

If the minimum impedance or the frequency is out of limit, check the fail column.

Calculating Sheet

Performance Test

Power Level Accuracy Test

Power Level	Frequency	Multimeter Reading [a]	Test Result [-16.99+20×log ₁₀ a]
-15 dBm	1 MHz	mV	dBm

Impedance Measurement Accuracy Test

16190B Calibration Value

Standard: Open Termination

Frequency	Measurement Parameter	Calibration Value	Reference Designation
1 MHz	Y	μS	CV1
10 MHz	Y	μS	CV2
100 MHz	Y	μS	CV3
200 MHz	Y	μS	CV4
300 MHz	Y	μS	CV5
500 MHz	Y	μS	CV6
600 MHz	Y	μS	CV7
800 MHz	Y	μS	CV8
1.0 GHz	Y	μS	CV9
1.3 GHz	Y	μS	CV10
1.6 GHz	Y	μS	CV11
1.8 GHz	Y	μS	CV12
2.0 GHz	Y	μS	CV13
2.2 GHz	Y	μS	CV14
2.4 GHz	Y	μS	CV15
2.6 GHz	Y	μS	CV16
2.8 GHz	Y	μS	CV17
3.0 GHz	Y	μS	CV18

Performance Test and Function Test
Calculating Sheet

Standard: Short Termination

Frequency	Measurement Parameter	Calibration Value	Reference Designation
1 MHz	Z	mΩ	CV19
10 MHz	Z	mΩ	CV20
100 MHz	Z	mΩ	CV21
200 MHz	Z	mΩ	CV22
300 MHz	Z	mΩ	CV23
500 MHz	Z	mΩ	CV24
600 MHz	Z	mΩ	CV25
800 MHz	Z	mΩ	CV26
1.0 GHz	Z	mΩ	CV27
1.3 GHz	Z	mΩ	CV28
1.6 GHz	Z	mΩ	CV29
1.8 GHz	Z	mΩ	CV30
2.0 GHz	Z	mΩ	CV31
2.2 GHz	Z	mΩ	CV32
2.4 GHz	Z	mΩ	CV33
2.6 GHz	Z	mΩ	CV34
2.8 GHz	Z	mΩ	CV35
3.0 GHz	Z	mΩ	CV36

Standard: 50 Ω Termination

Frequency	Measurement Parameter	Calibration Value	Reference Designation
1 MHz	Z	Ω	CV37
	θ	mrad	CV38
10 MHz	Z	Ω	CV39
	θ	mrad	CV40
100 MHz	Z	Ω	CV41
	θ	mrad	CV42
200 MHz	Z	Ω	CV43
	θ	mrad	CV44
300 MHz	Z	Ω	CV45
	θ	mrad	CV46
500 MHz	Z	Ω	CV47
	θ	mrad	CV48
600 MHz	Z	Ω	CV49
	θ	mrad	CV50
800 MHz	Z	Ω	CV51
	θ	mrad	CV52
1.0 GHz	Z	Ω	CV53
	θ	mrad	CV54
1.3 GHz	Z	Ω	CV55
	θ	mrad	CV56
1.6 GHz	Z	Ω	CV57
	θ	mrad	CV58
1.8 GHz	Z	Ω	CV59
	θ	mrad	CV60
2.0 GHz	Z	Ω	CV61
	θ	mrad	CV62
2.2 GHz	Z	Ω	CV63
	θ	mrad	CV64
2.4 GHz	Z	Ω	CV65

Performance Test and Function Test
Calculating Sheet

Frequency	Measurement Parameter	Calibration Value	Reference Designation
	θ	mrاد	CV66
2.6 GHz	$ Z $	Ω	CV67
	θ	mrاد	CV68
2.8 GHz	$ Z $	Ω	CV69
	θ	mrاد	CV70
3.0 GHz	$ Z $	Ω	CV71
	θ	mrاد	CV72

Standard: Airline with Open Termination

Frequency	Measurement Parameter	Calibration Value	Reference Designation
1 MHz	Z	kΩ	CV73
	θ	mrاد	CV74
10 MHz	Z	Ω	CV75
	θ	mrاد	CV76
100 MHz	Z	Ω	CV77
	θ	mrاد	CV78
200 MHz	Z	Ω	CV79
	θ	mrاد	CV80
300 MHz	Z	Ω	CV81
	θ	mrاد	CV82
500 MHz	Z	Ω	CV83
	θ	mrاد	CV84
600 MHz	Z	Ω	CV85
	θ	mrاد	CV86
800 MHz	Z	Ω	CV87
	θ	mrاد	CV88
1.0 GHz	Z	Ω	CV89
	θ	mrاد	CV90
1.6 GHz	Z	Ω	CV91
	θ	mrاد	CV92
1.8 GHz	Z	Ω	CV93
	θ	mrاد	CV94
2.0 GHz	Z	Ω	CV95
	θ	mrاد	CV96
2.2 GHz	Z	Ω	CV97
	θ	mrاد	CV98
2.4 GHz	Z	Ω	CV99
	θ	mrاد	CV100
2.6 GHz	Z	Ω	CV101

Performance Test and Function Test
Calculating Sheet

Frequency	Measurement Parameter	Calibration Value	Reference Designation
	θ	mrad	CV102
3.0 GHz	$ Z $	Ω	CV103
	θ	mrad	CV104

Standard: Airline with Short Termination

Frequency	Measurement Parameter	Calibration Value	Reference Designation
1 MHz	Z	Ω	CV105
	θ	mrad	CV106
10 MHz	Z	Ω	CV107
	θ	mrad	CV108
100 MHz	Z	Ω	CV109
	θ	mrad	CV110
200 MHz	Z	Ω	CV111
	θ	mrad	CV112
300 MHz	Z	Ω	CV113
	θ	mrad	CV114
500 MHz	Z	Ω	CV115
	θ	mrad	CV116
600 MHz	Z	Ω	CV117
	θ	mrad	CV118
1.0 GHz	Z	Ω	CV119
	θ	mrad	CV120
1.3 GHz	Z	Ω	CV121
	θ	mrad	CV122
1.6 GHz	Z	Ω	CV123
	θ	mrad	CV124
1.8 GHz	Z	Ω	CV125
	θ	mrad	CV126
2.0 GHz	Z	Ω	CV127
	θ	mrad	CV128
2.4 GHz	Z	Ω	CV129
	θ	mrad	CV130
2.6 GHz	Z	Ω	CV131
	θ	mrad	CV132
2.8 GHz	Z	Ω	CV133

Performance Test and Function Test
Calculating Sheet

Frequency	Measurement Parameter	Calibration Value	Reference Designation
	θ	mrad	CV134

Impedance Measurement Accuracy Test

Standard: Open
Averaging 8

Freq.	Power Level	Measurement Parameter	E4991A Reading [a]	Test Result Equation
1 MHz	-3 dBm	Y	μS	a-CV1
10 MHz	-3 dBm	Y	μS	a-CV2
100 MHz	-3 dBm	Y	μS	a-CV3
200 MHz	-3 dBm	Y	μS	a-CV4
300 MHz	-3 dBm	Y	μS	a-CV5
500 MHz	-3 dBm	Y	μS	a-CV6
600 MHz	-3 dBm	Y	μS	a-CV7
800 MHz	-3 dBm	Y	μS	a-CV8
1.0 GHz	-3 dBm	Y	μS	a-CV9
1.3 GHz	-3 dBm	Y	μS	a-CV10
1.6 GHz	-3 dBm	Y	μS	a-CV11
1.8 GHz	-3 dBm	Y	μS	a-CV12
2.0 GHz	-3 dBm	Y	μS	a-CV13
2.2 GHz	-3 dBm	Y	μS	a-CV14
2.4 GHz	-3 dBm	Y	μS	a-CV15
2.6 GHz	-3 dBm	Y	μS	a-CV16
2.8 GHz	-3 dBm	Y	μS	a-CV17
3.0 GHz	-3 dBm	Y	μS	a-CV18

Performance Test and Function Test
Calculating Sheet

Standard: Short
Averaging 8

Freq.	Power Level	Measurement Parameter	E4991A Reading [a]	Test Result Equation
1 MHz	-3 dBm	Z	mΩ	a-CV19
10 MHz	-3 dBm	Z	mΩ	a-CV20
100 MHz	-3 dBm	Z	mΩ	a-CV21
200 MHz	-3 dBm	Z	mΩ	a-CV22
300 MHz	-3 dBm	Z	mΩ	a-CV23
500 MHz	-3 dBm	Z	mΩ	a-CV24
600 MHz	-3 dBm	Z	mΩ	a-CV25
800 MHz	-3 dBm	Z	mΩ	a-CV26
1.0 GHz	-3 dBm	Z	mΩ	a-CV27
1.3 GHz	-3 dBm	Z	mΩ	a-CV28
1.6 GHz	-3 dBm	Z	mΩ	a-CV29
1.8 GHz	-3 dBm	Z	mΩ	a-CV30
2.0 GHz	-3 dBm	Z	mΩ	a-CV31
2.2 GHz	-3 dBm	Z	mΩ	a-CV32
2.4 GHz	-3 dBm	Z	mΩ	a-CV33
2.6 GHz	-3 dBm	Z	mΩ	a-CV34
2.8 GHz	-3 dBm	Z	mΩ	a-CV35
3.0 GHz	-3 dBm	Z	mΩ	a-CV36

Standard: 50 Ω
Averaging 8

Freq.	Power Level	Measurement Parameter	E4991A Reading [a]	Test Result Equation
1 MHz	-3 dBm	Z	Ω	a-CV37
		θ	mrad	a-CV38
10 MHz	-3 dBm	Z	Ω	a-CV39
		θ	mrad	a-CV40
100 MHz	-3 dBm	Z	Ω	a-CV41
		θ	mrad	a-CV42
200 MHz	-3 dBm	Z	Ω	a-CV43
		θ	mrad	a-CV44
300 MHz	-3 dBm	Z	Ω	a-CV45
		θ	mrad	a-CV46
500 MHz	-3 dBm	Z	Ω	a-CV47
		θ	mrad	a-CV48
600 MHz	-3 dBm	Z	Ω	a-CV49
		θ	mrad	a-CV50
800 MHz	-3 dBm	Z	Ω	a-CV51
		θ	mrad	a-CV52
1.0 GHz	-3 dBm	Z	Ω	a-CV53
		θ	mrad	a-CV54
1.3 GHz	-3 dBm	Z	Ω	a-CV55
		θ	mrad	a-CV56
1.6 GHz	-3 dBm	Z	Ω	a-CV57
		θ	mrad	a-CV58
1.8 GHz	-3 dBm	Z	Ω	a-CV59
		θ	mrad	a-CV60
2.0 GHz	-3 dBm	Z	Ω	a-CV61
		θ	mrad	a-CV62
2.2 GHz	-3 dBm	Z	Ω	a-CV63
		θ	mrad	a-CV64

Performance Test and Function Test
Calculating Sheet

Freq.	Power Level	Measurement Parameter	E4991A Reading [a]	Test Result Equation
2.4 GHz	-3 dBm	Z	Ω	a-CV65
		θ	mrad	a-CV66
2.6 GHz	-3 dBm	Z	Ω	a-CV67
		θ	mrad	a-CV68
2.8 GHz	-3 dBm	Z	Ω	a-CV69
		θ	mrad	a-CV70
3.0 GHz	-3 dBm	Z	Ω	a-CV71
		θ	mrad	a-CV72

Standard: Airline with Open
Averaging 8

Freq.	Power Level	Measurement Parameter	E4991A Reading [a]	Test Result Equation
1 MHz	-3 dBm	Z	kΩ	a-CV73
		θ	mrاد	a-CV74
10 MHz	-3 dBm	Z	Ω	a-CV75
		θ	mrاد	a-CV76
100 MHz	-3 dBm	Z	Ω	a-CV77
		θ	mrاد	a-CV78
200 MHz	-3 dBm	Z	Ω	a-CV79
		θ	mrاد	a-CV80
300 MHz	-3 dBm	Z	Ω	a-CV81
		θ	mrاد	a-CV82
500 MHz	-3 dBm	Z	Ω	a-CV83
		θ	mrاد	a-CV84
600 MHz	-3 dBm	Z	Ω	a-CV85
		θ	mrاد	a-CV86
800 MHz	-3 dBm	Z	Ω	a-CV87
		θ	mrاد	a-CV88
1.0 GHz	-3 dBm	Z	Ω	a-CV89
		θ	mrاد	a-CV90
1.6 GHz	-3 dBm	Z	Ω	a-CV91
		θ	mrاد	a-CV92
1.8 GHz	-3 dBm	Z	Ω	a-CV93
		θ	mrاد	a-CV94
2.0 GHz	-3 dBm	Z	Ω	a-CV95
		θ	mrاد	a-CV96
2.2 GHz	-3 dBm	Z	Ω	a-CV97
		θ	mrاد	a-CV98
2.4 GHz	-3 dBm	Z	Ω	a-CV99
		θ	mrاد	a-CV100

Performance Test and Function Test
Calculating Sheet

Freq.	Power Level	Measurement Parameter	E4991A Reading [a]	Test Result Equation
2.6 GHz	-3 dBm	Z	Ω	a-CV101
		θ	mrad	a-CV102
3.0 GHz	-3 dBm	Z	Ω	a-CV103
		θ	mrad	a-CV104

Standard: Airline with Open
Averaging 1

Freq.	Power Level	Measurement Parameter	E4991A Reading [a]	Test Result Equation
1 MHz	-20 dBm	Z	kΩ	a-CV73
		θ	mrاد	a-CV74
10 MHz	-20 dBm	Z	Ω	a-CV75
		θ	mrاد	a-CV76
100 MHz	-20 dBm	Z	Ω	a-CV77
		θ	mrاد	a-CV78
200 MHz	-20 dBm	Z	Ω	a-CV79
		θ	mrاد	a-CV80
300 MHz	-20 dBm	Z	Ω	a-CV81
		θ	mrاد	a-CV82
500 MHz	-20 dBm	Z	Ω	a-CV83
		θ	mrاد	a-CV84
600 MHz	-20 dBm	Z	Ω	a-CV85
		θ	mrاد	a-CV86
800 MHz	-20 dBm	Z	Ω	a-CV87
		θ	mrاد	a-CV88
1.0 GHz	-20 dBm	Z	Ω	a-CV89
		θ	mrاد	a-CV90
1.6 GHz	-20 dBm	Z	Ω	a-CV91
		θ	mrاد	a-CV92
1.8 GHz	-20 dBm	Z	Ω	a-CV93
		θ	mrاد	a-CV94
2.0 GHz	-20 dBm	Z	Ω	a-CV95
		θ	mrاد	a-CV96
2.2 GHz	-20 dBm	Z	Ω	a-CV97
		θ	mrاد	a-CV98
2.4 GHz	-20 dBm	Z	Ω	a-CV99
		θ	mrاد	a-CV100

Performance Test and Function Test
Calculating Sheet

Freq.	Power Level	Measurement Parameter	E4991A Reading [a]	Test Result Equation
2.6 GHz	-20 dBm	Z	Ω	a-CV101
		θ	mrad	a-CV102
3.0 GHz	-20 dBm	Z	Ω	a-CV103
		θ	mrad	a-CV104

Standard: Airline with Short
Averaging 8

Freq.	Power Level	Measurement Parameter	E4991A Reading [a]	Test Result Equation
1 MHz	-3 dBm	Z	Ω	a-CV105
		θ	mrad	a-CV106
10 MHz	-3 dBm	Z	Ω	a-CV107
		θ	mrad	a-CV108
100 MHz	-3 dBm	Z	Ω	a-CV109
		θ	mrad	a-CV110
200 MHz	-3 dBm	Z	Ω	a-CV111
		θ	mrad	a-CV112
300 MHz	-3 dBm	Z	Ω	a-CV113
		θ	mrad	a-CV114
500 MHz	-3 dBm	Z	Ω	a-CV115
		θ	mrad	a-CV116
600 MHz	-3 dBm	Z	Ω	a-CV117
		θ	mrad	a-CV118
1.0 GHz	-3 dBm	Z	Ω	a-CV119
		θ	mrad	a-CV120
1.3 GHz	-3 dBm	Z	Ω	a-CV121
		θ	mrad	a-CV122
1.6 GHz	-3 dBm	Z	Ω	a-CV123
		θ	mrad	a-CV124
1.8 GHz	-3 dBm	Z	Ω	a-CV125
		θ	mrad	a-CV126
2.0 GHz	-3 dBm	Z	Ω	a-CV127
		θ	mrad	a-CV128
2.4 GHz	-3 dBm	Z	Ω	a-CV129
		θ	mrad	a-CV130
2.6 GHz	-3 dBm	Z	Ω	a-CV131
		θ	mrad	a-CV132

2. Performance Test and Function Test

Performance Test and Function Test
Calculating Sheet

Freq.	Power Level	Measurement Parameter	E4991A Reading [a]	Test Result Equation
2.8 GHz	-3 dBm	Z	Ω	a-CV133
		θ	mrad	a-CV134

Standard: Airline with Short
Averaging 1

Freq.	Power Level	Measurement Parameter	E4991A Reading [a]	Test Result Equation
1 MHz	-40 dBm	Z	Ω	a-CV105
		θ	mrad	a-CV106
10 MHz	-40 dBm	Z	Ω	a-CV107
		θ	mrad	a-CV108
100 MHz	-40 dBm	Z	Ω	a-CV109
		θ	mrad	a-CV110
200 MHz	-40 dBm	Z	Ω	a-CV111
		θ	mrad	a-CV112
300 MHz	-40 dBm	Z	Ω	a-CV113
		θ	mrad	a-CV114
500 MHz	-40 dBm	Z	Ω	a-CV115
		θ	mrad	a-CV116
600 MHz	-40 dBm	Z	Ω	a-CV117
		θ	mrad	a-CV118
1.0 GHz	-40 dBm	Z	Ω	a-CV119
		θ	mrad	a-CV120
1.3 GHz	-40 dBm	Z	Ω	a-CV121
		θ	mrad	a-CV122
1.6 GHz	-40 dBm	Z	Ω	a-CV123
		θ	mrad	a-CV124
1.8 GHz	-40 dBm	Z	Ω	a-CV125
		θ	mrad	a-CV126
2.0 GHz	-40 dBm	Z	Ω	a-CV127
		θ	mrad	a-CV128
2.4 GHz	-40 dBm	Z	Ω	a-CV129
		θ	mrad	a-CV130
2.6 GHz	-40 dBm	Z	Ω	a-CV131
		θ	mrad	a-CV132

2. Performance Test and Function Test

Performance Test and Function Test
Calculating Sheet

Freq.	Power Level	Measurement Parameter	E4991A Reading [a]	Test Result Equation
2.8 GHz	-40 dBm	Z	Ω	a-CV133
		θ	mrad	a-CV134

Function Test

Low Loss Capacitor Test

Description	Lower Limit	Reading	Upper Limit
Minimum Impedance	0 Ω	m Ω	100 m Ω
Frequency	5.2 GHz	GHz	5.8 GHz

Test Record

Performance Test Record

Agilent Technologies E4991A RF Impedance/Material Analyzer

Mainframe: Serial No.		Test Date	
Test Head: Serial No.		Temperature	°C
Calibration Kit Serial No.		Humidity	%R.H.
		Tested by	

Frequency Accuracy Test

Without Option 1D5

Frequency	Test Limit	Test Result	Measurement Uncertainty
1 MHz	±10.00 Hz	Hz	±0.21 Hz
3 GHz	±30.00 kHz	kHz	±0.64 kHz

With Option 1D5

Frequency	Test Limit	Test Result	Measurement Uncertainty
1 MHz	±1.00 Hz	Hz	±0.21 Hz
3 GHz	±3.00 kHz	kHz	±0.64 kHz

OSC Level Accuracy Test

Power Level	Frequency	Test Limit	Test Result	Measurement Uncertainty
1 dBm	1 GHz	±2.00 dB	dB	±0.22 dB
0 dBm	3 GHz	±3.00 dB	dB	±0.35 dB
-7.9 dBm	3 GHz	±3.00 dB	dB	±0.35 dB
-10 dBm	300 MHz	±2.00 dB	dB	±0.26 dB
-15 dBm	1 MHz	±2.00 dB	dB	±0.22 dB
-20 dBm	50 MHz	±2.00 dB	dB	±0.24 dB
-25 dBm	1 GHz	±2.00 dB	dB	±0.24 dB

Power Level	Frequency	Test Limit	Test Result	Measurement Uncertainty
-30 dBm	10 MHz	± 2.00 dB	dB	± 0.22 dB
-35 dBm	2 GHz	± 3.00 dB	dB	± 0.24 dB
-40 dBm	100 MHz	± 2.00 dB	dB	± 0.27 dB

Performance Test and Function Test
Test Record

Impedance Measurement Accuracy Test

Standard: Open
 Averaging: 8

Frequency	Power Level	Measurement Parameter	Test Limit	Test Result	Measurement Uncertainty
1 MHz	-3 dBm	Y	±5.13 μS	μS	±0.61 μS
10 MHz	-3 dBm	Y	±6.26 μS	μS	±0.46 μS
100 MHz	-3 dBm	Y	±17.6 μS	μS	±3.3 μS
200 MHz	-3 dBm	Y	±31.4 μS	μS	±6.5 μS
300 MHz	-3 dBm	Y	±44.7 μS	μS	±9.8 μS
500 MHz	-3 dBm	Y	±72 μS	μS	±17 μS
600 MHz	-3 dBm	Y	±95 μS	μS	±21 μS
800 MHz	-3 dBm	Y	±127 μS	μS	±28 μS
1.0 GHz	-3 dBm	Y	±161 μS	μS	±35 μS
1.3 GHz	-3 dBm	Y	±284 μS	μS	±46 μS
1.6 GHz	-3 dBm	Y	±362 μS	μS	±61 μS
1.8 GHz	-3 dBm	Y	±420 μS	μS	±69 μS
2.0 GHz	-3 dBm	Y	±689 μS	μS	±126 μS
2.2 GHz	-3 dBm	Y	±781 μS	μS	±140 μS
2.4 GHz	-3 dBm	Y	±881 μS	μS	±155 μS
2.6 GHz	-3 dBm	Y	±991 μS	μS	±171 μS
2.8 GHz	-3 dBm	Y	±1111 μS	μS	±186 μS
3.0 GHz	-3 dBm	Y	±1244 μS	μS	±203 μS

Standard: Short
Averaging: 8

Frequency	Power Level	Measurement Parameter	Test Limit	Test Result	Measurement Uncertainty
1 MHz	-3 dBm	Z	±13.5 mΩ	mΩ	±2.6 mΩ
10 MHz	-3 dBm	Z	±18.0 mΩ	mΩ	±3.6 mΩ
100 MHz	-3 dBm	Z	±63 mΩ	mΩ	±15 mΩ
200 MHz	-3 dBm	Z	±113 mΩ	mΩ	±26 mΩ
300 MHz	-3 dBm	Z	±163 mΩ	mΩ	±31 mΩ
500 MHz	-3 dBm	Z	±263 mΩ	mΩ	±51 mΩ
600 MHz	-3 dBm	Z	±313 mΩ	mΩ	±51 mΩ
800 MHz	-3 dBm	Z	±413 mΩ	mΩ	±51 mΩ
1.0 GHz	-3 dBm	Z	±513 mΩ	mΩ	±51 mΩ
1.3 GHz	-3 dBm	Z	±663 mΩ	mΩ	±101 mΩ
1.6 GHz	-3 dBm	Z	±813 mΩ	mΩ	±101 mΩ
1.8 GHz	-3 dBm	Z	±913 mΩ	mΩ	±101 mΩ
2.0 GHz	-3 dBm	Z	±1013 mΩ	mΩ	±201 mΩ
2.2 GHz	-3 dBm	Z	±1113 mΩ	mΩ	±201 mΩ
2.4 GHz	-3 dBm	Z	±1213 mΩ	mΩ	±201 mΩ
2.6 GHz	-3 dBm	Z	±1313 mΩ	mΩ	±201 mΩ
2.8 GHz	-3 dBm	Z	±1413 mΩ	mΩ	±201 mΩ
3.0 GHz	-3 dBm	Z	±1513 mΩ	mΩ	±201 mΩ

Performance Test and Function Test
Test Record

Standard: 50 Ω
Averaging: 8

Frequency	Power Level	Measurement Parameter	Test Limit	Test Result	Measurement Uncertainty
1 MHz	-3 dBm	Z	$\pm 0.35 \Omega$	Ω	$\pm 0.09 \Omega$
		θ	$\pm 7.0 \text{ mrad}$	mrad	$\pm 1.7 \text{ mrad}$
10 MHz	-3 dBm	Z	$\pm 0.36 \Omega$	Ω	$\pm 0.09 \Omega$
		θ	$\pm 7.2 \text{ mrad}$	mrad	$\pm 1.7 \text{ mrad}$
100 MHz	-3 dBm	Z	$\pm 0.43 \Omega$	Ω	$\pm 0.09 \Omega$
		θ	$\pm 8.5 \text{ mrad}$	mrad	$\pm 1.7 \text{ mrad}$
200 MHz	-3 dBm	Z	$\pm 0.58 \Omega$	Ω	$\pm 0.11 \Omega$
		θ	$\pm 11.5 \text{ mrad}$	mrad	$\pm 2.2 \text{ mrad}$
300 MHz	-3 dBm	Z	$\pm 0.65 \Omega$	Ω	$\pm 0.14 \Omega$
		θ	$\pm 13.0 \text{ mrad}$	mrad	$\pm 2.7 \text{ mrad}$
500 MHz	-3 dBm	Z	$\pm 0.80 \Omega$	Ω	$\pm 0.19 \Omega$
		θ	$\pm 16.0 \text{ mrad}$	mrad	$\pm 3.7 \text{ mrad}$
600 MHz	-3 dBm	Z	$\pm 1.08 \Omega$	Ω	$\pm 0.23 \Omega$
		θ	$\pm 21.5 \text{ mrad}$	mrad	$\pm 4.6 \text{ mrad}$
800 MHz	-3 dBm	Z	$\pm 1.23 \Omega$	Ω	$\pm 0.23 \Omega$
		θ	$\pm 24.5 \text{ mrad}$	mrad	$\pm 4.6 \text{ mrad}$
1.0 GHz	-3 dBm	Z	$\pm 1.38 \Omega$	Ω	$\pm 0.23 \Omega$
		θ	$\pm 27.5 \text{ mrad}$	mrad	$\pm 4.6 \text{ mrad}$
1.3 GHz	-3 dBm	Z	$\pm 2.25 \Omega$	Ω	$\pm 0.24 \Omega$
		θ	$\pm 45.0 \text{ mrad}$	mrad	$\pm 4.7 \text{ mrad}$
1.6 GHz	-3 dBm	Z	$\pm 2.48 \Omega$	Ω	$\pm 0.24 \Omega$
		θ	$\pm 49.5 \text{ mrad}$	mrad	$\pm 4.8 \text{ mrad}$
1.8 GHz	-3 dBm	Z	$\pm 2.63 \Omega$	Ω	$\pm 0.24 \Omega$
		θ	$\pm 52.5 \text{ mrad}$	mrad	$\pm 4.6 \text{ mrad}$
2.0 GHz	-3 dBm	Z	$\pm 4.02 \Omega$	Ω	$\pm 0.51 \Omega$
		θ	$\pm 80.5 \text{ mrad}$	mrad	$\pm 10.1 \text{ mrad}$
2.2 GHz	-3 dBm	Z	$\pm 4.17 \Omega$	Ω	$\pm 0.51 \Omega$
		θ	$\pm 83.5 \text{ mrad}$	mrad	$\pm 10.2 \text{ mrad}$

Frequency	Power Level	Measurement Parameter	Test Limit	Test Result	Measurement Uncertainty
2.4 GHz	-3 dBm	Z	$\pm 4.32 \Omega$	Ω	$\pm 0.51 \Omega$
		θ	$\pm 86.5 \text{ mrad}$	mrad	$\pm 10.1 \text{ mrad}$
2.6 GHz	-3 dBm	Z	$\pm 4.47 \Omega$	Ω	$\pm 0.51 \Omega$
		θ	$\pm 89.5 \text{ mrad}$	mrad	$\pm 10.2 \text{ mrad}$
2.8 GHz	-3 dBm	Z	$\pm 4.62 \Omega$	Ω	$\pm 0.53 \Omega$
		θ	$\pm 92.5 \text{ mrad}$	mrad	$\pm 10.2 \text{ mrad}$
3.0 GHz	-3 dBm	Z	$\pm 4.77 \Omega$	Ω	$\pm 0.53 \Omega$
		θ	$\pm 95.5 \text{ mrad}$	mrad	$\pm 10.9 \text{ mrad}$

Performance Test and Function Test
Test Record

Standard: 10 cm Airline with Open
Averaging: 8

Frequency	Power Level	Measurement Parameter	Test Limit	Test Result	Measurement Uncertainty
1 MHz	-3 dBm	Z	±2.6 kΩ	kΩ	±254 Ω
		θ	±117.8 mrad	mrاد	±17.6 mrad
10 MHz	-3 dBm	Z	±42.8 Ω	Ω	±4.3 Ω
		θ	±19.6 mrad	mrاد	±2.0 mrad
100 MHz	-3 dBm	Z	±2.15 Ω	Ω	±0.42 Ω
		θ	±10.0 mrad	mrاد	±2.0 mrad
200 MHz	-3 dBm	Z	±1.18 Ω	Ω	±0.22 Ω
		θ	±11.7 mrad	mrاد	±2.2 mrad
300 MHz	-3 dBm	Z	±0.78 Ω	Ω	±0.16 Ω
		θ	±12.8 mrad	mrاد	±2.6 mrad
500 MHz	-3 dBm	Z	±0.47 Ω	Ω	±0.09 Ω
		θ	±20.9 mrad	mrاد	±3.7 mrad
600 MHz	-3 dBm	Z	±0.44 Ω	Ω	±0.09 Ω
		θ	±44.5 mrad	mrاد	±8.7 mrad
800 MHz	-3 dBm	Z	±0.59 Ω	Ω	±0.12 Ω
		θ	±43.5 mrad	mrاد	±8.7 mrad
1.0 GHz	-3 dBm	Z	±1.25 Ω	Ω	±0.23 Ω
		θ	±28.2 mrad	mrاد	±5.2 mrad
1.6 GHz	-3 dBm	Z	±4.17 Ω	Ω	±0.72 Ω
		θ	±48.6 mrad	mrاد	±8.4 mrad
1.8 GHz	-3 dBm	Z	±1.95 Ω	Ω	±0.29 Ω
		θ	±58.7 mrad	mrاد	±8.5 mrad
2.0 GHz	-3 dBm	Z	±1.34 Ω	Ω	±0.10 Ω
		θ	±211.6 mrad	mrاد	±14.3 mrad
2.2 GHz	-3 dBm	Z	±2.05 Ω	Ω	±0.23 Ω
		θ	±118.2 mrad	mrاد	±12.8 mrad
2.4 GHz	-3 dBm	Z	±4.37 Ω	Ω	±0.64 Ω
		θ	±86.4 mrad	mrاد	±12.5 mrad

Frequency	Power Level	Measurement Parameter	Test Limit	Test Result	Measurement Uncertainty
2.6 GHz	-3 dBm	Z	±14.8 Ω	Ω	±2.2 Ω
		θ	±98.6 mrad	mrad	±14.4 mrad
3.0 GHz	-3 dBm	Z	±6.9 Ω	Ω	±1.1 Ω
		θ	±93.0 mrad	mrad	±13.8 mrad

Performance Test and Function Test
Test Record

Standard: 10 cm Airline with Open
Averaging: 1

Frequency	Power Level	Measurement Parameter	Test Limit	Test Result	Measurement Uncertainty
1 MHz	-20 dBm	Z	±14.5 kΩ	kΩ	±1771 Ω
		θ	±663.4 mrad	mrاد	±50.6 mrad
10 MHz	-20 dBm	Z	±161.8 Ω	Ω	±7.7 Ω
		θ	±74.2 mrad	mrاد	±5.3 mrad
100 MHz	-20 dBm	Z	±3.33 Ω	Ω	±0.42 Ω
		θ	±15.5 mrad	mrاد	±2.1 mrad
200 MHz	-20 dBm	Z	±1.47 Ω	Ω	±0.22 Ω
		θ	±14.6 mrad	mrاد	±2.2 mrad
300 MHz	-20 dBm	Z	±0.91 Ω	Ω	±0.16 Ω
		θ	±14.9 mrad	mrاد	±2.6 mrad
500 MHz	-20 dBm	Z	±0.52 Ω	Ω	±0.09 Ω
		θ	±23.1 mrad	mrاد	±3.7 mrad
600 MHz	-20 dBm	Z	±0.48 Ω	Ω	±0.09 Ω
		θ	±48.5 mrad	mrاد	±8.7 mrad
800 MHz	-20 dBm	Z	±0.63 Ω	Ω	±0.12 Ω
		θ	±46.6 mrad	mrاد	±8.7 mrad
1.0 GHz	-20 dBm	Z	±1.34 Ω	Ω	±0.23 Ω
		θ	±30.2 mrad	mrاد	±5.2 mrad
1.6 GHz	-20 dBm	Z	±4.39 Ω	Ω	±0.72 Ω
		θ	±51.2 mrad	mrاد	±8.4 mrad
1.8 GHz	-20 dBm	Z	±2.01 Ω	Ω	±0.29 Ω
		θ	±60.6 mrad	mrاد	±8.5 mrad
2.0 GHz	-20 dBm	Z	±1.38 Ω	Ω	±0.10 Ω
		θ	±217.6 mrad	mrاد	±14.4 mrad
2.2 GHz	-20 dBm	Z	±2.09 Ω	Ω	±0.23 Ω
		θ	±120.7 mrad	mrاد	±12.8 mrad
2.4 GHz	-20 dBm	Z	±4.47 Ω	Ω	±0.64 Ω
		θ	±88.4 mrad	mrاد	±12.5 mrad

Frequency	Power Level	Measurement Parameter	Test Limit	Test Result	Measurement Uncertainty
2.6 GHz	-20 dBm	Z	±15.4 Ω	Ω	±2.2 Ω
		θ	±102.6 mrad	mrاد	±14.4 mrad
3.0 GHz	-20 dBm	Z	±7.1 Ω	Ω	±1.1 Ω
		θ	±95.4 mrad	mrاد	±13.9 mrad

Performance Test and Function Test
Test Record

Standard: 10 cm Airline with Short
Averaging: 8

Frequency	Power Level	Measurement Parameter	Test Limit	Test Result	Measurement Uncertainty
1 MHz	-3 dBm	Z	±0.010 Ω	Ω	±0.002 Ω
		θ	±125.4 mrad	mrاد	±19.4 mrad
10 MHz	-3 dBm	Z	±0.020 Ω	Ω	±0.005 Ω
		θ	±23.3 mrad	mrاد	±4.2 mrad
100 MHz	-3 dBm	Z	±0.13 Ω	Ω	±0.03 Ω
		θ	±12.5 mrad	mrاد	±2.5 mrad
200 MHz	-3 dBm	Z	±0.30 Ω	Ω	±0.07 Ω
		θ	±13.6 mrad	mrاد	±3.0 mrad
300 MHz	-3 dBm	Z	±0.50 Ω	Ω	±0.11 Ω
		θ	±13.7 mrad	mrاد	±3.0 mrad
500 MHz	-3 dBm	Z	±1.38 Ω	Ω	±0.31 Ω
		θ	±15.8 mrad	mrاد	±3.5 mrad
600 MHz	-3 dBm	Z	±3.75 Ω	Ω	±0.77 Ω
		θ	±24.1 mrad	mrاد	±5.0 mrad
1.0 GHz	-3 dBm	Z	±2.32 Ω	Ω	±0.45 Ω
		θ	±27.0 mrad	mrاد	±5.2 mrad
1.3 GHz	-3 dBm	Z	±1.28 Ω	Ω	±0.19 Ω
		θ	±58.0 mrad	mrاد	±8.3 mrad
1.6 GHz	-3 dBm	Z	±1.10 Ω	Ω	±0.12 Ω
		θ	±101.6 mrad	mrاد	±10.8 mrad
1.8 GHz	-3 dBm	Z	±2.08 Ω	Ω	±0.31 Ω
		θ	±56.7 mrad	mrاد	±8.3 mrad
2.0 GHz	-3 dBm	Z	±6.97 Ω	Ω	±0.91 Ω
		θ	±79.5 mrad	mrاد	±10.4 mrad
2.4 GHz	-3 dBm	Z	±14.38 Ω	Ω	±2.06 Ω
		θ	±95.1 mrad	mrاد	±13.6 mrad
2.6 GHz	-3 dBm	Z	±4.86 Ω	Ω	±0.74 Ω
		θ	±88.5 mrad	mrاد	±13.4 mrad

Frequency	Power Level	Measurement Parameter	Test Limit	Test Result	Measurement Uncertainty
2.8 GHz	-3 dBm	$ Z $	$\pm 2.65 \Omega$	Ω	$\pm 0.30 \Omega$
		θ	$\pm 120.6 \text{ mrad}$	mrad	$\pm 13.6 \text{ mrad}$

Performance Test and Function Test
Test Record

Standard: 10 cm Airline with Short
Averaging: 1

Frequency	Power Level	Measurement Parameter	Test Limit	Test Result	Measurement Uncertainty
1 MHz	-40 dBm	Z	±0.100 Ω	Ω	±0.010 Ω
		θ	±892.0 mrad	mrad	±68.1 mrad
10 MHz	-40 dBm	Z	±0.110 Ω	Ω	±0.011 Ω
		θ	±104.2 mrad	mrad	±8.5 mrad
100 MHz	-40 dBm	Z	±0.23 Ω	Ω	±0.03 Ω
		θ	±21.2 mrad	mrad	±2.9 mrad
200 MHz	-40 dBm	Z	±0.42 Ω	Ω	±0.07 Ω
		θ	±18.7 mrad	mrad	±3.0 mrad
300 MHz	-40 dBm	Z	±0.66 Ω	Ω	±0.12 Ω
		θ	±18.1 mrad	mrad	±3.0 mrad
500 MHz	-40 dBm	Z	±1.88 Ω	Ω	±0.31 Ω
		θ	±21.6 mrad	mrad	±3.6 mrad
600 MHz	-40 dBm	Z	±5.17 Ω	Ω	±0.80 Ω
		θ	±33.2 mrad	mrad	±5.1 mrad
1.0 GHz	-40 dBm	Z	±2.82 Ω	Ω	±0.45 Ω
		θ	±32.7 mrad	mrad	±5.2 mrad
1.3 GHz	-40 dBm	Z	±1.39 Ω	Ω	±0.19 Ω
		θ	±63.2 mrad	mrad	±8.3 mrad
1.6 GHz	-40 dBm	Z	±1.20 Ω	Ω	±0.12 Ω
		θ	±110.2 mrad	mrad	±11.0 mrad
1.8 GHz	-40 dBm	Z	±2.24 Ω	Ω	±0.31 Ω
		θ	±61.1 mrad	mrad	±8.4 mrad
2.0 GHz	-40 dBm	Z	±7.48 Ω	Ω	±0.92 Ω
		θ	±85.3 mrad	mrad	±10.4 mrad
2.4 GHz	-40 dBm	Z	±15.72 Ω	Ω	±2.06 Ω
		θ	±104.0 mrad	mrad	±13.6 mrad
2.6 GHz	-40 dBm	Z	±5.12 Ω	Ω	±0.74 Ω
		θ	±93.1 mrad	mrad	±13.4 mrad

Frequency	Power Level	Measurement Parameter	Test Limit	Test Result	Measurement Uncertainty
2.8 GHz	-40 dBm	Z	$\pm 2.76 \Omega$	Ω	$\pm 0.30 \Omega$
		θ	$\pm 125.8 \text{ mrad}$	mrad	$\pm 13.7 \text{ mrad}$

Performance Test and Function Test
Test Record

DC Bias Test (Option 001)

Bias Level	Test Limit	Test Result	Measurement Uncertainty
-40 V	± 46.00 mV	mV	± 0.99 mV
-4 V	± 10.0 mV	mV	± 57.3 μ V
0 V	± 6.00 mV	mV	± 27.8 μ V
4 V	± 10.0 mV	mV	± 48.6 μ V
40 V	± 46.00 mV	mV	± 0.98 mV
-50 mA	± 120.0 μ A	μ A	± 9.4 μ A
-4 mA	± 28.0 μ A	μ A	± 1.2 μ A
-100 μ A	± 20.2 μ A	μ A	± 1.0 μ A
100 μ A	± 20.2 μ A	μ A	± 1.2 μ A
4 mA	± 28.0 μ A	μ A	± 1.2 μ A
50 mA	± 120.0 μ A	μ A	± 9.1 μ A

Performance Test Record (Option 007)

OSC Level Accuracy Test (Option 007)

Power Level	Frequency	Test Limit	Test Result	Measurement Uncertainty
1 dBm	1 GHz	-4.00/+2.00 dB	dB	±0.22 dB
0 dBm	3 GHz	-6.00/+3.00 dB	dB	±0.35 dB
-7.9 dBm	3 GHz	-6.00/+3.00 dB	dB	±0.35 dB
-10 dBm	300 MHz	-4.00/+2.00 dB	dB	±0.26 dB
-15 dBm	1 MHz	-4.00/+2.00 dB	dB	±0.22 dB
-20 dBm	50 MHz	-4.00/+2.00 dB	dB	±0.24 dB
-25 dBm	1 GHz	-4.00/+2.00 dB	dB	±0.24 dB
-30 dBm	10 MHz	-4.00/+2.00 dB	dB	±0.22 dB
-35 dBm	2 GHz	-6.00/+3.00 dB	dB	±0.24 dB
-40 dBm	100 MHz	-4.00/+2.00 dB	dB	±0.27 dB

2. Performance Test and
 Function Test

Performance Test and Function Test
Test Record

Impedance Measurement Accuracy Test (Option 007)

Standard: Open
 Averaging: 8

Frequency	Power Level	Measurement Parameter	Test Limit	Test Result	Measurement Uncertainty
1 MHz	-3 dBm	Y	±12.13 μS	μS	±0.38 μS
10 MHz	-3 dBm	Y	±13.31 μS	μS	±0.80 μS
100 MHz	-3 dBm	Y	±25.2 μS	μS	±3.4 μS
200 MHz	-3 dBm	Y	±40.0 μS	μS	±6.6 μS
300 MHz	-3 dBm	Y	±54.1 μS	μS	±9.8 μS
500 MHz	-3 dBm	Y	±82 μS	μS	±17 μS
600 MHz	-3 dBm	Y	±102 μS	μS	±21 μS
800 MHz	-3 dBm	Y	±134 μS	μS	±28 μS
1.0 GHz	-3 dBm	Y	±168 μS	μS	±35 μS
1.3 GHz	-3 dBm	Y	±291 μS	μS	±46 μS
1.6 GHz	-3 dBm	Y	±369 μS	μS	±61 μS
1.8 GHz	-3 dBm	Y	±427 μS	μS	±70 μS
2.0 GHz	-3 dBm	Y	±697 μS	μS	±126 μS
2.2 GHz	-3 dBm	Y	±789 μS	μS	±140 μS
2.4 GHz	-3 dBm	Y	±890 μS	μS	±156 μS
2.6 GHz	-3 dBm	Y	±999 μS	μS	±171 μS
2.8 GHz	-3 dBm	Y	±1121 μS	μS	±186 μS
3.0 GHz	-3 dBm	Y	±1254 μS	μS	±205 μS

Standard: Short
Averaging: 8

Frequency	Power Level	Measurement Parameter	Test Limit	Test Result	Measurement Uncertainty
1 MHz	-3 dBm	Z	±30.5 mΩ	mΩ	±3.1 mΩ
10 MHz	-3 dBm	Z	±35.0 mΩ	mΩ	±3.6 mΩ
100 MHz	-3 dBm	Z	±80 mΩ	mΩ	±15 mΩ
200 MHz	-3 dBm	Z	±130 mΩ	mΩ	±26 mΩ
300 MHz	-3 dBm	Z	±180 mΩ	mΩ	±31 mΩ
500 MHz	-3 dBm	Z	±280 mΩ	mΩ	±51 mΩ
600 MHz	-3 dBm	Z	±330 mΩ	mΩ	±51 mΩ
800 MHz	-3 dBm	Z	±430 mΩ	mΩ	±51 mΩ
1.0 GHz	-3 dBm	Z	±530 mΩ	mΩ	±51 mΩ
1.3 GHz	-3 dBm	Z	±680 mΩ	mΩ	±101 mΩ
1.6 GHz	-3 dBm	Z	±830 mΩ	mΩ	±101 mΩ
1.8 GHz	-3 dBm	Z	±930 mΩ	mΩ	±101 mΩ
2.0 GHz	-3 dBm	Z	±1030 mΩ	mΩ	±201 mΩ
2.2 GHz	-3 dBm	Z	±1130 mΩ	mΩ	±201 mΩ
2.4 GHz	-3 dBm	Z	±1230 mΩ	mΩ	±201 mΩ
2.6 GHz	-3 dBm	Z	±1330 mΩ	mΩ	±201 mΩ
2.8 GHz	-3 dBm	Z	±1430 mΩ	mΩ	±201 mΩ
3.0 GHz	-3 dBm	Z	±1530 mΩ	mΩ	±201 mΩ

Performance Test and Function Test
Test Record

Standard: 50 Ω
Averaging: 8

Frequency	Power Level	Measurement Parameter	Test Limit	Test Result	Measurement Uncertainty
1 MHz	-3 dBm	Z	$\pm 0.46 \Omega$	Ω	$\pm 0.09 \Omega$
		θ	$\pm 9.2 \text{ mrad}$	mrad	$\pm 1.7 \text{ mrad}$
10 MHz	-3 dBm	Z	$\pm 0.46 \Omega$	Ω	$\pm 0.09 \Omega$
		θ	$\pm 9.3 \text{ mrad}$	mrad	$\pm 1.7 \text{ mrad}$
100 MHz	-3 dBm	Z	$\pm 0.53 \Omega$	Ω	$\pm 0.09 \Omega$
		θ	$\pm 10.7 \text{ mrad}$	mrad	$\pm 1.7 \text{ mrad}$
200 MHz	-3 dBm	Z	$\pm 0.71 \Omega$	Ω	$\pm 0.11 \Omega$
		θ	$\pm 14.2 \text{ mrad}$	mrad	$\pm 2.2 \text{ mrad}$
300 MHz	-3 dBm	Z	$\pm 0.78 \Omega$	Ω	$\pm 0.14 \Omega$
		θ	$\pm 15.7 \text{ mrad}$	mrad	$\pm 2.7 \text{ mrad}$
500 MHz	-3 dBm	Z	$\pm 0.93 \Omega$	Ω	$\pm 0.19 \Omega$
		θ	$\pm 18.6 \text{ mrad}$	mrad	$\pm 3.7 \text{ mrad}$
600 MHz	-3 dBm	Z	$\pm 1.11 \Omega$	Ω	$\pm 0.23 \Omega$
		θ	$\pm 22.1 \text{ mrad}$	mrad	$\pm 4.6 \text{ mrad}$
800 MHz	-3 dBm	Z	$\pm 1.26 \Omega$	Ω	$\pm 0.23 \Omega$
		θ	$\pm 25.1 \text{ mrad}$	mrad	$\pm 4.6 \text{ mrad}$
1.0 GHz	-3 dBm	Z	$\pm 1.41 \Omega$	Ω	$\pm 0.24 \Omega$
		θ	$\pm 28.1 \text{ mrad}$	mrad	$\pm 4.6 \text{ mrad}$
1.3 GHz	-3 dBm	Z	$\pm 2.28 \Omega$	Ω	$\pm 0.24 \Omega$
		θ	$\pm 45.6 \text{ mrad}$	mrad	$\pm 4.7 \text{ mrad}$
1.6 GHz	-3 dBm	Z	$\pm 2.51 \Omega$	Ω	$\pm 0.24 \Omega$
		θ	$\pm 50.2 \text{ mrad}$	mrad	$\pm 4.8 \text{ mrad}$
1.8 GHz	-3 dBm	Z	$\pm 2.66 \Omega$	Ω	$\pm 0.24 \Omega$
		θ	$\pm 53.2 \text{ mrad}$	mrad	$\pm 4.8 \text{ mrad}$
2.0 GHz	-3 dBm	Z	$\pm 4.05 \Omega$	Ω	$\pm 0.51 \Omega$
		θ	$\pm 81.2 \text{ mrad}$	mrad	$\pm 10.2 \text{ mrad}$
2.2 GHz	-3 dBm	Z	$\pm 4.20 \Omega$	Ω	$\pm 0.51 \Omega$
		θ	$\pm 84.2 \text{ mrad}$	mrad	$\pm 10.3 \text{ mrad}$

Frequency	Power Level	Measurement Parameter	Test Limit	Test Result	Measurement Uncertainty
2.4 GHz	-3 dBm	Z	±4.35 Ω	Ω	±0.51 Ω
		θ	±87.2 mrad	mrad	±10.2 mrad
2.6 GHz	-3 dBm	Z	±4.50 Ω	Ω	±0.51 Ω
		θ	±90.2 mrad	mrad	±10.3 mrad
2.8 GHz	-3 dBm	Z	±4.65 Ω	Ω	±0.51 Ω
		θ	±93.2 mrad	mrad	±10.3 mrad
3.0 GHz	-3 dBm	Z	±4.80 Ω	Ω	±0.51 Ω
		θ	±96.2 mrad	mrad	±10.3 mrad

Performance Test and Function Test
Test Record

Standard: 10 cm Airline with Open
Averaging: 8

Frequency	Power Level	Measurement Parameter	Test Limit	Test Result	Measurement Uncertainty
1 MHz	-3 dBm	Z	±5.9 kΩ	kΩ	±296 Ω
		θ	±272.0 mrad	mrاد	±10.3 mrad
10 MHz	-3 dBm	Z	±79.3 Ω	Ω	±5.3 Ω
		θ	±36.3 mrad	mrاد	±2.3 mrad
100 MHz	-3 dBm	Z	±2.80 Ω	Ω	±0.42 Ω
		θ	±13.0 mrad	mrاد	±2.0 mrad
200 MHz	-3 dBm	Z	±1.47 Ω	Ω	±0.22 Ω
		θ	±14.5 mrad	mrاد	±2.2 mrad
300 MHz	-3 dBm	Z	±0.94 Ω	Ω	±0.16 Ω
		θ	±15.5 mrad	mrاد	±2.6 mrad
500 MHz	-3 dBm	Z	±0.53 Ω	Ω	±0.09 Ω
		θ	±23.8 mrad	mrاد	±3.8 mrad
600 MHz	-3 dBm	Z	±0.45 Ω	Ω	±0.09 Ω
		θ	±46.3 mrad	mrاد	±8.7 mrad
800 MHz	-3 dBm	Z	±0.61 Ω	Ω	±0.12 Ω
		θ	±44.8 mrad	mrاد	±8.7 mrad
1.0 GHz	-3 dBm	Z	±1.28 Ω	Ω	±0.23 Ω
		θ	±28.9 mrad	mrاد	±5.2 mrad
1.6 GHz	-3 dBm	Z	±4.24 Ω	Ω	±0.72 Ω
		θ	±49.4 mrad	mrاد	±8.4 mrad
1.8 GHz	-3 dBm	Z	±1.97 Ω	Ω	±0.29 Ω
		θ	±59.4 mrad	mrاد	±8.5 mrad
2.0 GHz	-3 dBm	Z	±1.35 Ω	Ω	±0.10 Ω
		θ	±214.3 mrad	mrاد	±14.4 mrad
2.2 GHz	-3 dBm	Z	±2.06 Ω	Ω	±0.23 Ω
		θ	±119.2 mrad	mrاد	±12.8 mrad
2.4 GHz	-3 dBm	Z	±4.40 Ω	Ω	±0.64 Ω
		θ	±87.0 mrad	mrاد	±12.6 mrad

Frequency	Power Level	Measurement Parameter	Test Limit	Test Result	Measurement Uncertainty
2.6 GHz	-3 dBm	Z	$\pm 14.9 \Omega$	Ω	$\pm 2.2 \Omega$
		θ	$\pm 99.7 \text{ mrad}$	mrad	$\pm 14.4 \text{ mrad}$
3.0 GHz	-3 dBm	Z	$\pm 6.9 \Omega$	Ω	$\pm 1.1 \Omega$
		θ	$\pm 93.7 \text{ mrad}$	mrad	$\pm 13.9 \text{ mrad}$

Performance Test and Function Test
Test Record

Standard: 10 cm Airline with Open
Averaging: 1

Frequency	Power Level	Measurement Parameter	Test Limit	Test Result	Measurement Uncertainty
1 MHz	-20 dBm	Z	±19.2 kΩ	kΩ	±969 Ω
		θ	±883.1 mrad	mrاد	±61.5 mrad
10 MHz	-20 dBm	Z	±212.7 Ω	Ω	±10.5 Ω
		θ	±97.5 mrad	mrاد	±3.4 mrad
100 MHz	-20 dBm	Z	±4.13 Ω	Ω	±0.42 Ω
		θ	±19.2 mrad	mrاد	±2.0 mrad
200 MHz	-20 dBm	Z	±1.8 Ω	Ω	±0.23 Ω
		θ	±17.7 mrad	mrاد	±2.2 mrad
300 MHz	-20 dBm	Z	±1.08 Ω	Ω	±0.17 Ω
		θ	±17.8 mrad	mrاد	±2.6 mrad
500 MHz	-20 dBm	Z	±0.59 Ω	Ω	±0.09 Ω
		θ	±26.2 mrad	mrاد	±3.8 mrad
600 MHz	-20 dBm	Z	±0.49 Ω	Ω	±0.09 Ω
		θ	±50.6 mrad	mrاد	±8.7 mrad
800 MHz	-20 dBm	Z	±0.65 Ω	Ω	±0.12 Ω
		θ	±48.1 mrad	mrاد	±8.8 mrad
1.0 GHz	-20 dBm	Z	±1.37 Ω	Ω	±0.23 Ω
		θ	±31.0 mrad	mrاد	±5.2 mrad
1.6 GHz	-20 dBm	Z	±4.48 Ω	Ω	±0.72 Ω
		θ	±52.3 mrad	mrاد	±8.4 mrad
1.8 GHz	-20 dBm	Z	±2.04 Ω	Ω	±0.29 Ω
		θ	±61.5 mrad	mrاد	±8.5 mrad
2.0 GHz	-20 dBm	Z	±1.39 Ω	Ω	±0.10 Ω
		θ	±220.8 mrad	mrاد	±14.3 mrad
2.2 GHz	-20 dBm	Z	±2.11 Ω	Ω	±0.23 Ω
		θ	±122.0 mrad	mrاد	±12.8 mrad
2.4 GHz	-20 dBm	Z	±4.51 Ω	Ω	±0.64 Ω
		θ	±89.2 mrad	mrاد	±12.6 mrad

Frequency	Power Level	Measurement Parameter	Test Limit	Test Result	Measurement Uncertainty
2.6 GHz	-20 dBm	Z	±15.6Ω	Ω	±2.2 Ω
		θ	±104.1 mrad	mrاد	±14.4 mrad
3.0 GHz	-20 dBm	Z	±7.1 Ω	Ω	±1.1 Ω
		θ	±96.3 mrad	mrاد	±13.9 mrad

Performance Test and Function Test
Test Record

Standard: 10 cm Airline with Short
Averaging: 8

Frequency	Power Level	Measurement Parameter	Test Limit	Test Result	Measurement Uncertainty
1 MHz	-3 dBm	Z	±0.031 Ω	Ω	±0.002 Ω
		θ	±276.7 mrad	mrad	±27.2 mrad
10 MHz	-3 dBm	Z	±0.043 Ω	Ω	±0.005 Ω
		θ	±40.5 mrad	mrad	±4.4 mrad
100 MHz	-3 dBm	Z	±0.16 Ω	Ω	±0.03 Ω
		θ	±15.7 mrad	mrad	±2.5 mrad
200 MHz	-3 dBm	Z	±0.37 Ω	Ω	±0.07 Ω
		θ	±16.5 mrad	mrad	±3.0 mrad
300 MHz	-3 dBm	Z	±0.60 Ω	Ω	±0.11 Ω
		θ	±16.4 mrad	mrad	±3.0 mrad
500 MHz	-3 dBm	Z	±1.62 Ω	Ω	±0.31 Ω
		θ	±18.6 mrad	mrad	±3.5 mrad
600 MHz	-3 dBm	Z	±3.93 Ω	Ω	±0.77 Ω
		θ	±25.3 mrad	mrad	±5.0 mrad
1.0 GHz	-3 dBm	Z	±2.39 Ω	Ω	±0.46 Ω
		θ	±27.8 mrad	mrad	±5.2 mrad
1.3 GHz	-3 dBm	Z	±1.30 Ω	Ω	±0.19 Ω
		θ	±58.9 mrad	mrad	±8.3 mrad
1.6 GHz	-3 dBm	Z	±1.12 Ω	Ω	±0.12 Ω
		θ	±103.2 mrad	mrad	±10.9 mrad
1.8 GHz	-3 dBm	Z	±2.10 Ω	Ω	±0.31 Ω
		θ	±57.3 mrad	mrad	±8.4 mrad
2.0 GHz	-3 dBm	Z	±7.04 Ω	Ω	±0.91 Ω
		θ	±80.3 mrad	mrad	±10.4 mrad
2.4 GHz	-3 dBm	Z	±14.55 Ω	Ω	±2.07 Ω
		θ	±96.2 mrad	mrad	±13.6 mrad
2.6 GHz	-3 dBm	Z	±4.90 Ω	Ω	±0.74 Ω
		θ	±89.1 mrad	mrad	±13.4 mrad

Frequency	Power Level	Measurement Parameter	Test Limit	Test Result	Measurement Uncertainty
2.8 GHz	-3 dBm	$ Z $	$\pm 2.66 \Omega$	Ω	$\pm 0.30 \Omega$
		θ	$\pm 121.5 \text{ mrad}$	mrad	$\pm 13.6 \text{ mrad}$

Performance Test and Function Test
Test Record

Standard: 10 cm Airline with Short
Averaging: 1

Frequency	Power Level	Measurement Parameter	Test Limit	Test Result	Measurement Uncertainty
1 MHz	-40 dBm	Z	±0.151 Ω	Ω	±0.007 Ω
		θ	±1338.0 mrad	mrad	±89.7 mrad
10 MHz	-40 dBm	Z	±0.168 Ω	Ω	±0.008 Ω
		θ	±156.2 mrad	mrad	±13.7 mrad
100 MHz	-40 dBm	Z	±0.33 Ω	Ω	±0.04 Ω
		θ	±31.6 mrad	mrad	±2.7 mrad
200 MHz	-40 dBm	Z	±0.63 Ω	Ω	±0.07 Ω
		θ	±28.4 mrad	mrad	±3.1 mrad
300 MHz	-40 dBm	Z	±0.99 Ω	Ω	±0.12 Ω
		θ	±27.2 mrad	mrad	±3.0 mrad
500 MHz	-40 dBm	Z	±2.69 Ω	Ω	±0.31 Ω
		θ	±30.9 mrad	mrad	±3.6 mrad
600 MHz	-40 dBm	Z	±6.16 Ω	Ω	±0.78 Ω
		θ	±39.6 mrad	mrad	±5.1 mrad
1.0 GHz	-40 dBm	Z	±3.27 Ω	Ω	±0.45 Ω
		θ	±38.0 mrad	mrad	±5.3 mrad
1.3 GHz	-40 dBm	Z	±1.45 Ω	Ω	±0.19 Ω
		θ	±65.8 mrad	mrad	±8.3 mrad
1.6 GHz	-40 dBm	Z	±1.25 Ω	Ω	±0.12 Ω
		θ	±115.0 mrad	mrad	±10.9 mrad
1.8 GHz	-40 dBm	Z	±2.31 Ω	Ω	±0.31 Ω
		θ	±63.1 mrad	mrad	±8.4 mrad
2.0 GHz	-40 dBm	Z	±7.68 Ω	Ω	±0.92 Ω
		θ	±87.6 mrad	mrad	±10.5 mrad
2.4 GHz	-40 dBm	Z	±16.23 Ω	Ω	±2.06 Ω
		θ	±107.3 mrad	mrad	±13.7 mrad
2.6 GHz	-40 dBm	Z	±5.22 Ω	Ω	±0.74 Ω
		θ	±95.0 mrad	mrad	±13.4 mrad

Frequency	Power Level	Measurement Parameter	Test Limit	Test Result	Measurement Uncertainty
2.8 GHz	-40 dBm	Z	$\pm 2.82 \Omega$	Ω	$\pm 0.30 \Omega$
		θ	$\pm 128.4 \text{ mrad}$	mrad	$\pm 13.6 \text{ mrad}$

Performance Test Record (Option 010)

Frequency Accuracy Test (Option 010)

Without Option 1D5

Frequency	Test Limit	Test Result	Measurement Uncertainty
1 MHz	±10.00 Hz	Hz	±0.21 Hz
3 GHz	±30.00 kHz	kHz	±0.64 kHz

With Option 1D5

Frequency	Test Limit	Test Result	Measurement Uncertainty
1 MHz	±1.00 Hz	Hz	±0.21 Hz
3 GHz	±3.00 kHz	kHz	±0.64 kHz

OSC Level Accuracy Test (Option 010)

Power Level	Frequency	Test Limit	Test Result	Measurement Uncertainty
1 dBm	1 GHz	±3.50 dB	dB	±0.22 dB
0 dBm	3 GHz	±5.60 dB	dB	±0.35 dB
-7.9 dBm	3 GHz	±5.60 dB	dB	±0.35 dB
-10 dBm	300 MHz	±3.50 dB	dB	±0.26 dB
-15 dBm	1 MHz	±3.50 dB	dB	±0.22 dB
-20 dBm	50 MHz	±3.50 dB	dB	±0.24 dB
-25 dBm	1 GHz	±3.50 dB	dB	±0.24 dB
-30 dBm	10 MHz	±3.50 dB	dB	±0.22 dB
-35 dBm	2 GHz	±5.60 dB	dB	±0.24 dB
-40 dBm	100 MHz	±3.50 dB	dB	±0.27 dB

Impedance Measurement Accuracy Test (Option 010)

Standard: Open
Averaging: 8

Frequency	Power Level	Measurement Parameter	Test Limit	Test Result	Measurement Uncertainty
1 MHz	-3 dBm	Y	±5.13 μS	μS	±0.61 μS
10 MHz	-3 dBm	Y	±6.26 μS	μS	±0.46 μS
100 MHz	-3 dBm	Y	±17.6 μS	μS	±3.3 μS
200 MHz	-3 dBm	Y	±31.4 μS	μS	±6.5 μS
300 MHz	-3 dBm	Y	±44.7 μS	μS	±9.8 μS
500 MHz	-3 dBm	Y	±72 μS	μS	±17 μS
600 MHz	-3 dBm	Y	±95 μS	μS	±21 μS
800 MHz	-3 dBm	Y	±127 μS	μS	±28 μS
1.0 GHz	-3 dBm	Y	±161 μS	μS	±35 μS
1.3 GHz	-3 dBm	Y	±284 μS	μS	±46 μS
1.6 GHz	-3 dBm	Y	±362 μS	μS	±61 μS
1.8 GHz	-3 dBm	Y	±420 μS	μS	±69 μS
2.0 GHz	-3 dBm	Y	±689 μS	μS	±126 μS
2.2 GHz	-3 dBm	Y	±781 μS	μS	±140 μS
2.4 GHz	-3 dBm	Y	±881 μS	μS	±155 μS
2.6 GHz	-3 dBm	Y	±991 μS	μS	±171 μS
2.8 GHz	-3 dBm	Y	±1111 μS	μS	±186 μS
3.0 GHz	-3 dBm	Y	±1244 μS	μS	±203 μS

Performance Test and Function Test
Test Record

Standard: Short
Averaging: 8

Frequency	Power Level	Measurement Parameter	Test Limit	Test Result	Measurement Uncertainty
1 MHz	-3 dBm	Z	±13.5 mΩ	mΩ	±2.6 mΩ
10 MHz	-3 dBm	Z	±18.0 mΩ	mΩ	±3.6 mΩ
100 MHz	-3 dBm	Z	±63 mΩ	mΩ	±15 mΩ
200 MHz	-3 dBm	Z	±113 mΩ	mΩ	±26 mΩ
300 MHz	-3 dBm	Z	±163 mΩ	mΩ	±31 mΩ
500 MHz	-3 dBm	Z	±263 mΩ	mΩ	±51 mΩ
600 MHz	-3 dBm	Z	±313 mΩ	mΩ	±51 mΩ
800 MHz	-3 dBm	Z	±413 mΩ	mΩ	±51 mΩ
1.0 GHz	-3 dBm	Z	±513 mΩ	mΩ	±51 mΩ
1.3 GHz	-3 dBm	Z	±663 mΩ	mΩ	±101 mΩ
1.6 GHz	-3 dBm	Z	±813 mΩ	mΩ	±101 mΩ
1.8 GHz	-3 dBm	Z	±913 mΩ	mΩ	±101 mΩ
2.0 GHz	-3 dBm	Z	±1013 mΩ	mΩ	±201 mΩ
2.2 GHz	-3 dBm	Z	±1113 mΩ	mΩ	±201 mΩ
2.4 GHz	-3 dBm	Z	±1213 mΩ	mΩ	±201 mΩ
2.6 GHz	-3 dBm	Z	±1313 mΩ	mΩ	±201 mΩ
2.8 GHz	-3 dBm	Z	±1413 mΩ	mΩ	±201 mΩ
3.0 GHz	-3 dBm	Z	±1513 mΩ	mΩ	±201 mΩ

Standard: 50 Ω
Averaging: 8

Frequency	Power Level	Measurement Parameter	Test Limit	Test Result	Measurement Uncertainty
1 MHz	-3 dBm	Z	±0.35 Ω	Ω	±0.09 Ω
		θ	±7.0 mrad	mrاد	±1.7 mrad
10 MHz	-3 dBm	Z	±0.36 Ω	Ω	±0.09 Ω
		θ	±7.2 mrad	mrاد	±1.7 mrad
100 MHz	-3 dBm	Z	±0.43 Ω	Ω	±0.09 Ω
		θ	±8.5 mrad	mrاد	±1.7 mrad
200 MHz	-3 dBm	Z	±0.58 Ω	Ω	±0.11 Ω
		θ	±11.5 mrad	mrاد	±2.2 mrad
300 MHz	-3 dBm	Z	±0.65 Ω	Ω	±0.14 Ω
		θ	±13.0 mrad	mrاد	±2.7 mrad
500 MHz	-3 dBm	Z	±0.80 Ω	Ω	±0.19 Ω
		θ	±16.0 mrad	mrاد	±3.7 mrad
600 MHz	-3 dBm	Z	±1.08 Ω	Ω	±0.23 Ω
		θ	±21.5 mrad	mrاد	±4.6 mrad
800 MHz	-3 dBm	Z	±1.23 Ω	Ω	±0.23 Ω
		θ	±24.5 mrad	mrاد	±4.6 mrad
1.0 GHz	-3 dBm	Z	±1.38 Ω	Ω	±0.23 Ω
		θ	±27.5 mrad	mrاد	±4.6 mrad
1.3 GHz	-3 dBm	Z	±2.25 Ω	Ω	±0.24 Ω
		θ	±45.0 mrad	mrاد	±4.7 mrad
1.6 GHz	-3 dBm	Z	±2.48 Ω	Ω	±0.24 Ω
		θ	±49.5 mrad	mrاد	±4.8 mrad
1.8 GHz	-3 dBm	Z	±2.63 Ω	Ω	±0.24 Ω
		θ	±52.5 mrad	mrاد	±4.6 mrad
2.0 GHz	-3 dBm	Z	±4.02 Ω	Ω	±0.51 Ω
		θ	±80.5 mrad	mrاد	±10.1 mrad
2.2 GHz	-3 dBm	Z	±4.17 Ω	Ω	±0.51 Ω
		θ	±83.5 mrad	mrاد	±10.2 mrad

2. Performance Test and Function Test

Performance Test and Function Test
Test Record

Frequency	Power Level	Measurement Parameter	Test Limit	Test Result	Measurement Uncertainty
2.4 GHz	-3 dBm	Z	±4.32 Ω	Ω	±0.51 Ω
		θ	±86.5 mrad	mrad	±10.1 mrad
2.6 GHz	-3 dBm	Z	±4.47 Ω	Ω	±0.51 Ω
		θ	±89.5 mrad	mrad	±10.2 mrad
2.8 GHz	-3 dBm	Z	±4.62 Ω	Ω	±0.53 Ω
		θ	±92.5 mrad	mrad	±10.2 mrad
3.0 GHz	-3 dBm	Z	±4.77 Ω	Ω	±0.53 Ω
		θ	±95.5 mrad	mrad	±10.9 mrad

Standard: 10 cm Airline with Open
Averaging: 8

Frequency	Power Level	Measurement Parameter	Test Limit	Test Result	Measurement Uncertainty
1 MHz	-3 dBm	Z	±2.6 kΩ	kΩ	±254 Ω
		θ	±117.8 mrad	mrاد	±17.6 mrad
10 MHz	-3 dBm	Z	±42.8 Ω	Ω	±4.3 Ω
		θ	±19.6 mrad	mrاد	±2.0 mrad
100 MHz	-3 dBm	Z	±2.15 Ω	Ω	±0.42 Ω
		θ	±10.0 mrad	mrاد	±2.0 mrad
200 MHz	-3 dBm	Z	±1.18 Ω	Ω	±0.22 Ω
		θ	±11.7 mrad	mrاد	±2.2 mrad
300 MHz	-3 dBm	Z	±0.78 Ω	Ω	±0.16 Ω
		θ	±12.8 mrad	mrاد	±2.6 mrad
500 MHz	-3 dBm	Z	±0.47 Ω	Ω	±0.09 Ω
		θ	±20.9 mrad	mrاد	±3.7 mrad
600 MHz	-3 dBm	Z	±0.44 Ω	Ω	±0.09 Ω
		θ	±44.5 mrad	mrاد	±8.7 mrad
800 MHz	-3 dBm	Z	±0.59 Ω	Ω	±0.12 Ω
		θ	±43.5 mrad	mrاد	±8.7 mrad
1.0 GHz	-3 dBm	Z	±1.25 Ω	Ω	±0.23 Ω
		θ	±28.2 mrad	mrاد	±5.2 mrad
1.6 GHz	-3 dBm	Z	±4.17 Ω	Ω	±0.72 Ω
		θ	±48.6 mrad	mrاد	±8.4 mrad
1.8 GHz	-3 dBm	Z	±1.95 Ω	Ω	±0.29 Ω
		θ	±58.7 mrad	mrاد	±8.5 mrad
2.0 GHz	-3 dBm	Z	±1.34 Ω	Ω	±0.10 Ω
		θ	±211.6 mrad	mrاد	±14.3 mrad
2.2 GHz	-3 dBm	Z	±2.05 Ω	Ω	±0.23 Ω
		θ	±118.2 mrad	mrاد	±12.8 mrad
2.4 GHz	-3 dBm	Z	±4.37 Ω	Ω	±0.64 Ω
		θ	±86.4 mrad	mrاد	±12.5 mrad

Performance Test and Function Test
Test Record

Frequency	Power Level	Measurement Parameter	Test Limit	Test Result	Measurement Uncertainty
2.6 GHz	-3 dBm	Z	$\pm 14.8 \Omega$	Ω	$\pm 2.2 \Omega$
		θ	$\pm 98.6 \text{ mrad}$	mrad	$\pm 14.4 \text{ mrad}$
3.0 GHz	-3 dBm	Z	$\pm 6.9 \Omega$	Ω	$\pm 1.1 \Omega$
		θ	$\pm 93.0 \text{ mrad}$	mrad	$\pm 13.8 \text{ mrad}$

Standard: 10 cm Airline with Open
Averaging: 1

Frequency	Power Level	Measurement Parameter	Test Limit	Test Result	Measurement Uncertainty
1 MHz	-20 dBm	Z	±14.5 kΩ	kΩ	±1771 Ω
		θ	±663.4 mrad	mrاد	±50.6 mrad
10 MHz	-20 dBm	Z	±161.8 Ω	Ω	±7.7 Ω
		θ	±74.2 mrad	mrاد	±5.3 mrad
100 MHz	-20 dBm	Z	±3.33 Ω	Ω	±0.42 Ω
		θ	±15.5 mrad	mrاد	±2.1 mrad
200 MHz	-20 dBm	Z	±1.47 Ω	Ω	±0.22 Ω
		θ	±14.6 mrad	mrاد	±2.2 mrad
300 MHz	-20 dBm	Z	±0.91 Ω	Ω	±0.16 Ω
		θ	±14.9 mrad	mrاد	±2.6 mrad
500 MHz	-20 dBm	Z	±0.52 Ω	Ω	±0.09 Ω
		θ	±23.1 mrad	mrاد	±3.7 mrad
600 MHz	-20 dBm	Z	±0.48 Ω	Ω	±0.09 Ω
		θ	±48.5 mrad	mrاد	±8.7 mrad
800 MHz	-20 dBm	Z	±0.63 Ω	Ω	±0.12 Ω
		θ	±46.6 mrad	mrاد	±8.7 mrad
1.0 GHz	-20 dBm	Z	±1.34 Ω	Ω	±0.23 Ω
		θ	±30.2 mrad	mrاد	±5.2 mrad
1.6 GHz	-20 dBm	Z	±4.39 Ω	Ω	±0.72 Ω
		θ	±51.2 mrad	mrاد	±8.4 mrad
1.8 GHz	-20 dBm	Z	±2.01 Ω	Ω	±0.29 Ω
		θ	±60.6 mrad	mrاد	±8.5 mrad
2.0 GHz	-20 dBm	Z	±1.38 Ω	Ω	±0.10 Ω
		θ	±217.6 mrad	mrاد	±14.4 mrad
2.2 GHz	-20 dBm	Z	±2.09 Ω	Ω	±0.23 Ω
		θ	±120.7 mrad	mrاد	±12.8 mrad
2.4 GHz	-20 dBm	Z	±4.47 Ω	Ω	±0.64 Ω
		θ	±88.4 mrad	mrاد	±12.5 mrad

Performance Test and Function Test
Test Record

Frequency	Power Level	Measurement Parameter	Test Limit	Test Result	Measurement Uncertainty
2.6 GHz	-20 dBm	Z	$\pm 15.4 \Omega$	Ω	$\pm 2.2 \Omega$
		θ	$\pm 102.6 \text{ mrad}$	mrad	$\pm 14.4 \text{ mrad}$
3.0 GHz	-20 dBm	Z	$\pm 7.1 \Omega$	Ω	$\pm 1.1 \Omega$
		θ	$\pm 95.4 \text{ mrad}$	mrad	$\pm 13.9 \text{ mrad}$

Standard: 10 cm Airline with Short
Averaging: 8

Frequency	Power Level	Measurement Parameter	Test Limit	Test Result	Measurement Uncertainty
1 MHz	-3 dBm	Z	±0.010 Ω	Ω	±0.002 Ω
		θ	±125.4 mrad	mrad	±19.4 mrad
10 MHz	-3 dBm	Z	±0.020 Ω	Ω	±0.005 Ω
		θ	±23.3 mrad	mrad	±4.2 mrad
100 MHz	-3 dBm	Z	±0.13 Ω	Ω	±0.03 Ω
		θ	±12.5 mrad	mrad	±2.5 mrad
200 MHz	-3 dBm	Z	±0.30 Ω	Ω	±0.07 Ω
		θ	±13.6 mrad	mrad	±3.0 mrad
300 MHz	-3 dBm	Z	±0.50 Ω	Ω	±0.11 Ω
		θ	±13.7 mrad	mrad	±3.0 mrad
500 MHz	-3 dBm	Z	±1.38 Ω	Ω	±0.31 Ω
		θ	±15.8 mrad	mrad	±3.5 mrad
600 MHz	-3 dBm	Z	±3.75 Ω	Ω	±0.77 Ω
		θ	±24.1 mrad	mrad	±5.0 mrad
1.0 GHz	-3 dBm	Z	±2.32 Ω	Ω	±0.45 Ω
		θ	±27.0 mrad	mrad	±5.2 mrad
1.3 GHz	-3 dBm	Z	±1.28 Ω	Ω	±0.19 Ω
		θ	±58.0 mrad	mrad	±8.3 mrad
1.6 GHz	-3 dBm	Z	±1.10 Ω	Ω	±0.12 Ω
		θ	±101.6 mrad	mrad	±10.8 mrad
1.8 GHz	-3 dBm	Z	±2.08 Ω	Ω	±0.31 Ω
		θ	±56.7 mrad	mrad	±8.3 mrad
2.0 GHz	-3 dBm	Z	±6.97 Ω	Ω	±0.91 Ω
		θ	±79.5 mrad	mrad	±10.4 mrad
2.4 GHz	-3 dBm	Z	±14.38 Ω	Ω	±2.06 Ω
		θ	±95.1 mrad	mrad	±13.6 mrad
2.6 GHz	-3 dBm	Z	±4.86 Ω	Ω	±0.74 Ω
		θ	±88.5 mrad	mrad	±13.4 mrad

Performance Test and Function Test
Test Record

Frequency	Power Level	Measurement Parameter	Test Limit	Test Result	Measurement Uncertainty
2.8 GHz	-3 dBm	$ Z $	$\pm 2.65 \Omega$	Ω	$\pm 0.30 \Omega$
		θ	$\pm 120.6 \text{ mrad}$	mrad	$\pm 13.6 \text{ mrad}$

Standard: 10 cm Airline with Short
Averaging: 1

Frequency	Power Level	Measurement Parameter	Test Limit	Test Result	Measurement Uncertainty
1 MHz	-40 dBm	Z	±0.100 Ω	Ω	±0.010 Ω
		θ	±892.0 mrad	mrاد	±68.1 mrad
10 MHz	-40 dBm	Z	±0.110 Ω	Ω	±0.011 Ω
		θ	±104.2 mrad	mrاد	±8.5 mrad
100 MHz	-40 dBm	Z	±0.23 Ω	Ω	±0.03 Ω
		θ	±21.2 mrad	mrاد	±2.9 mrad
200 MHz	-40 dBm	Z	±0.42 Ω	Ω	±0.07 Ω
		θ	±18.7 mrad	mrاد	±3.0 mrad
300 MHz	-40 dBm	Z	±0.66 Ω	Ω	±0.12 Ω
		θ	±18.1 mrad	mrاد	±3.0 mrad
500 MHz	-40 dBm	Z	±1.88 Ω	Ω	±0.31 Ω
		θ	±21.6 mrad	mrاد	±3.6 mrad
600 MHz	-40 dBm	Z	±5.17 Ω	Ω	±0.80 Ω
		θ	±33.2 mrad	mrاد	±5.1 mrad
1.0 GHz	-40 dBm	Z	±2.82 Ω	Ω	±0.45 Ω
		θ	±32.7 mrad	mrاد	±5.2 mrad
1.3 GHz	-40 dBm	Z	±1.39 Ω	Ω	±0.19 Ω
		θ	±63.2 mrad	mrاد	±8.3 mrad
1.6 GHz	-40 dBm	Z	±1.20 Ω	Ω	±0.12 Ω
		θ	±110.2 mrad	mrاد	±11.0 mrad
1.8 GHz	-40 dBm	Z	±2.24 Ω	Ω	±0.31 Ω
		θ	±61.1 mrad	mrاد	±8.4 mrad
2.0 GHz	-40 dBm	Z	±7.48 Ω	Ω	±0.92 Ω
		θ	±85.3 mrad	mrاد	±10.4 mrad
2.4 GHz	-40 dBm	Z	±15.72 Ω	Ω	±2.06 Ω
		θ	±104.0 mrad	mrاد	±13.6 mrad
2.6 GHz	-40 dBm	Z	±5.12 Ω	Ω	±0.74 Ω
		θ	±93.1 mrad	mrاد	±13.4 mrad

Performance Test and Function Test
Test Record

Frequency	Power Level	Measurement Parameter	Test Limit	Test Result	Measurement Uncertainty
2.8 GHz	-40 dBm	$ Z $	$\pm 2.76 \Omega$	Ω	$\pm 0.30 \Omega$
		θ	$\pm 125.8 \text{ mrad}$	mrad	$\pm 13.7 \text{ mrad}$

DC Bias Test (Option 001 & Option 010)

Bias Level	Test Limit	Test Result	Measurement Uncertainty
-40 V	±46.00 mV	mV	±0.87 mV
-4 V	±10.0 mV	mV	±68.5 µV
0 V	± 6.00 mV	mV	±13.3 µV
4 V	±10.0 mV	mV	±45.5 µV
40 V	±46.00 mV	mV	±0.88 mV
-50 mA	±120.0 µA	µA	±8.9 µA
-4 mA	±28.0 µA	µA	±1.2 µA
-100 µA	±20.2 µA	µA	±1.0 µA
100 µA	±20.2 µA	µA	±1.2 µA
4 mA	±28.0 µA	µA	±1.3 µA
50 mA	±120.0 µA	µA	±8.9 µA

2. Performance Test and
 Function Test

Performance Test and Function Test
Test Record

Function Test Record

Agilent Technologies E4991A RF Impedance/Material Analyzer

Mainframe: Serial No.		Test Date	
Test Head: Serial No.		Temperature	°C
Calibration Kit Serial No.		Humidity	%R.H.
		Tested by	

Low Loss Capacitor Test

Pass **Fail**
[] []

3 Adjustment

This chapter provides the adjustment procedure for the E4991A RF Impedance/Material Analyzer to ensure that the E4991A is within its specifications.

Safety Considerations

This manual contains NOTES, CAUTIONs, and WARNINGs that must be followed to ensure the safety of the operator and to keep the instrument in a safe and serviceable condition. The Adjustment must be performed by qualified service personnel.

WARNING

Any interruption of the protective ground conductor (inside or outside the equipment) or disconnection of the protective ground terminal can make the instrument dangerous. Intentional interruption of the protective ground system for any reason is prohibited.

Warm-up for Adjustment

Allow the E4991A to warm up for at least 30 minutes before you execute any of the adjustments.

Required Equipment

Table 1-1 lists the equipment required to perform the Adjustment procedures described in this chapter. Use only calibrated test equipment when adjusting the E4991A.

NOTE

The followings are indispensable to perform the adjustment. The service center must receive the following from the customer.

- Agilent E4991A
- 16195B 7-mm Calibration Kit (Furnished Accessory for E4991A)
- Standard Test Head (Furnished Accessory for E4991A)

If the E4991A has an Option 010 Probe Station Connection Kit, you have to perform the adjustment using the Standard Test Head only.

Preparation for using the Adjustment Program

The Adjustment must be performed using the Adjustment Program.

To use the Adjustment Program, some preparation is required. This section describes how to its procedure.

Required Controller

The following controller system is required to run the adjustment program.

Windows PC	PC-AT Compatible, RAM:≥64MBytes, CPU Pentium 200 MHz or faster
OS	Microsoft® Windows NT® (4.0), Windows 95®, Windows 98®, Windows 2000®
Software	Agilent VEE (5.0x or 6.0x)
GPIB Card	82350A, 82340B, 82341C/D

Installing a GPIB Card (82340B, 82341C/D or 82350A)

Install a GPIB Card into your computer (see the GPIB Card manual). The select code of the GPIB Card should be set to “7”.

Installing Agilent VEE for Personal Computer

Install the Agilent VEE into your computer (see the Agilent VEE for Windows®).

Installing Adjustment Program into Your PC

1. Make a copy of the E4991A adjustment program named ADJE4991A.EXE in a directory of the hard disk drive in your PC. The program is downloadable from the CTU-Kobe web site.
2. Double-click on the filename on the Windows Explorer to start extracting the self-extracting archive.
3. You will be prompted to enter directory name for installing the program files. Click UNZIP to use default directory (C:\ADJE4991A)
4. Confirm the message of “unzipped successfully” on WinZip Self-Extractor Display, and then click OK and Close.

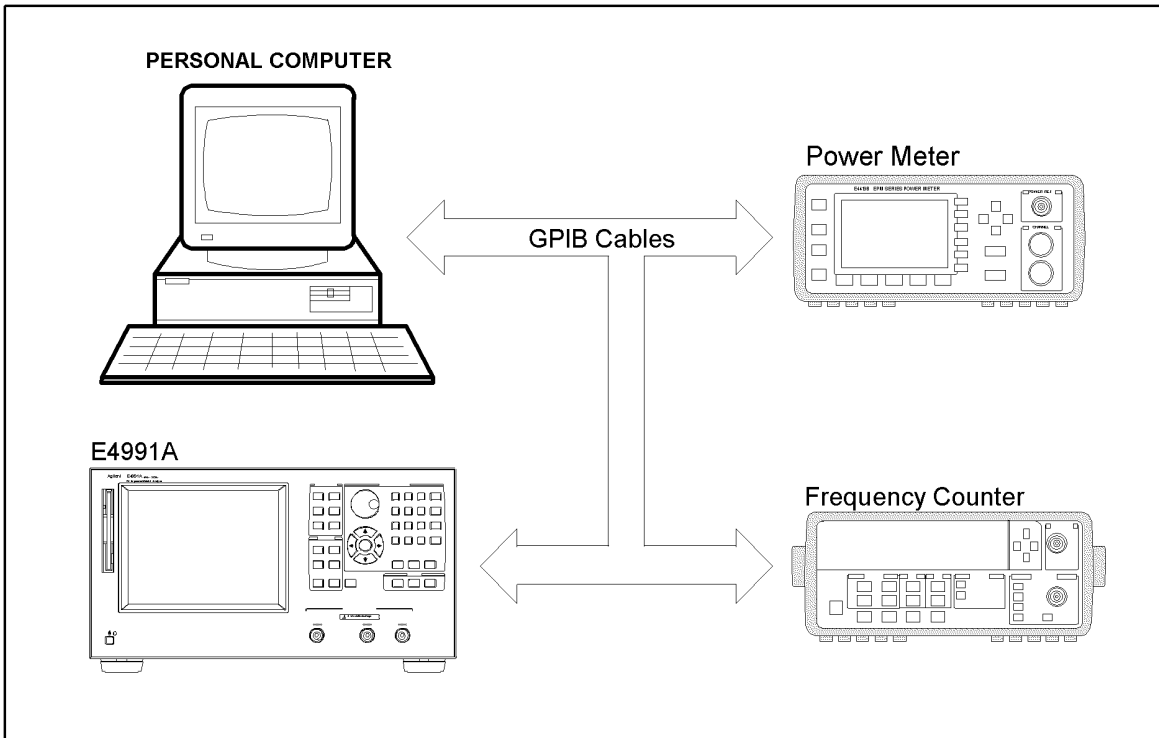
Adjustment
Preparation for using the Adjustment Program

Equipment Setup

Table 1-1 lists the equipment required to perform the Adjustment procedures described in this chapter. Use only calibrated test equipment when adjusting the E4991A.

Performing adjustments requires the system described in this section. The Hardware Setup is shown in Figure 3-1.

Figure 3-1 Adjustment Hardware Setup



e4991ase007

E4991A Control Mode

It is necessary to set the E4991A in addressable only mode to perform the adjustments. When your E4991A is set to system controller mode, set the E4991A in addressable only mode by the following E4991A mouse procedure.

- Step 1.** Click **System...** on the **System** menu.
- Step 2.** Click **GPIB Setup Menu** box.
- Step 3.** Select **Addressable Only** in the **Control Mode** box.
- Step 4.** Turn the E4991A's main power off and then back on again.

Or, set to addressable only mode by the following E4991A front panel procedure.

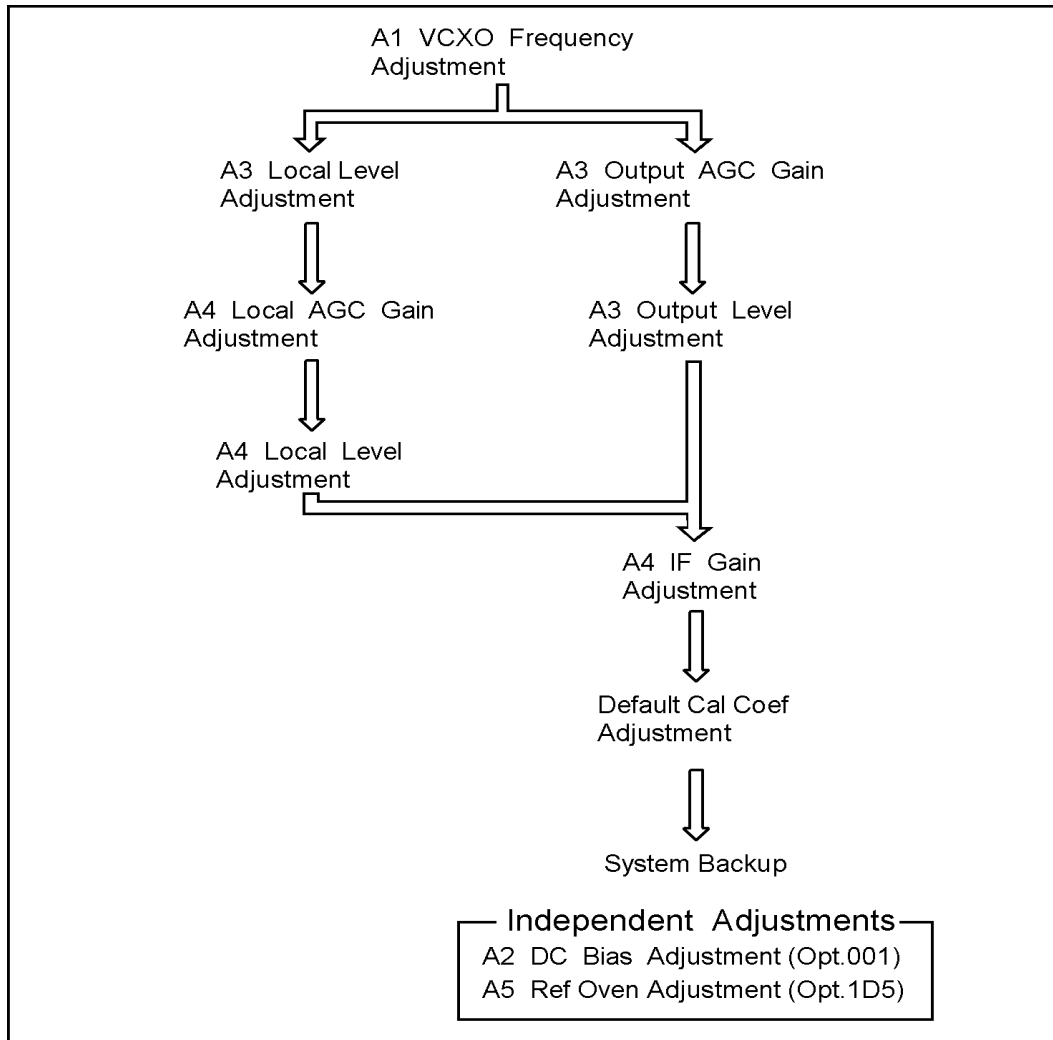
- Step 1.** Press [**System**] key on the front panel.
- Step 2.** Press [**Click**] key on the front panel.
- Step 3.** Press [**Click**] key again, if system controller mode is selected in the **Control Mode** box.
- Step 4.** Turn the E4991A's main power off and then back on again.

In addition, you can confirm the E4991A GPIB address by the above procedure.

Order of Adjustment

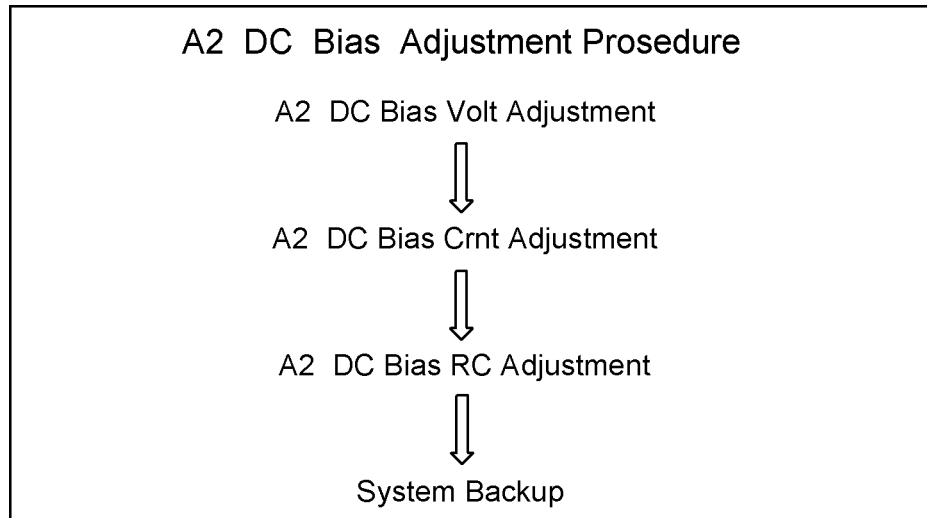
When performing more than one Adjustment, perform them in the order they appear in this chapter. The procedures are presented in the following order. For example, you need to perform the A4 Local AGC Gain Adjustment, A4 Local Level Adjustment, A4 IF Gain Adjustment, Default Cal Coef Adjustment and System Backup after performing the A3 Local Level Adjustment.

Figure 3-2 Order of Adjustment



e4991ase015

Figure 3-3 Order of DC Bias Adjustment



e4991ase022

The Spot Adjustment in the Adjustment Program can perform the following adjustments automatically according to Order of Adjustment as shown in Table 3-1.

Table 3-1 Required Adjustment Items in the Spot Adjustment

Spot Adjustment (in the Adjustment Program)	Adjustment Items											
	A1 VCXO Frequency Adjustment	A3 Local Level Adjustment	A3 Output AGC Gain Adjustment	A3 Output Level Adjustment	A4 Local AGC Gain Adjustment	A4 Local Level Adjustment	A4 IF Gain Adjustment	Default Cal Coefficient Adjustment	A2 DC Bias Voltage Adjustment (Opt.001)	A2 DC Bias Current Adjustment (Opt.001)	A2 DC Bias R/C Adjustment (Opt.001)	A5 Reference Oven Adjustment(Opt.1D5)
A1 Adjustment	*_>	*_>	*_>	*_>	*_>	*_>	*_>	*				
A3 Adjustment		*_>	*_>	*_>	*_>	*_>	*_>	*				
A4 Adjustment					*_>	*_>	*_>	*				
A2 Adjustment (Opt.001)									*_>	*_>	*	
A5 Adjustment (Opt.1D5)												*
Default Cal Adjustment								*				

3. Adjustment

Required Adjustment after Replacing Assembly

If you replace the following assembly, the adjustment items as shown in Table 3-2 are required. Then perform the corresponding adjustment using the Spot Adjustment in the Adjustment Program.

Table 3-2 Required Adjustment Item after Replacing Assembly

Replaced Assembly	Required Adjustment (Spot Adjustment in Adjustment Program)				
	A1 Adjustment	A3 Adjustment	A4 Adjustment	A2 Adjustment(Opt. 001)	A5 Adjustment(Opt.1D5)
A1 REFERENCE OSCILLATOR	√				
A3 SOURCE		√		√*1	
A4 RECEIVER			√	√*1	
A6 STANDARD TEST HEAD		√		√*1	
A2 DC Bias(Opt. 001)				√	
A5 10MHz OVEN(Opt.1D5)					√

*1. If your instrument has an option 001(A2 DC Bias), also perform A2 Adjustment.

Adjustment Program

This section describes the explanation of the function and the procedure of the Adjustment Program. For details, refer to the “Operation Manual for E4991A Adjustment Program”. The operation manual is downloadable from the CTU-Kobe web site

Adjustment Program Menu

The Adjustment Program has the following main menu.

- All Adjustment
- Spot Adjustment
- Write ID
- EEPROM Initialize

All Adjustment

All Adjustment executes all adjustments according to the option the E4991A has. When you replace the EEPROM on the A21 Analog Interface Board or A27 Mass Storage Disk Drive(HDD), All Adjustment must be performed.

All Adjustment consists of the following adjustments.

- EEPROM Initialize
- A1 VCXO Frequency Adjustment
- A3 Local Level Adjustment
- A3 Output AGC Gain Adjustment
- A3 Output Level Adjustment
- A4 Local AGC Gain Adjustment
- A4 Local Level Adjustment
- A4 IF Gain Adjustment
- Default Cal Coefficient Adjustment
- A5 Ref Oven Adjustment (Opt.1D5)
- A2 DC Bias Voltage Adjustment (Opt.001)
- A2 DC Bias Current Adjustment (Opt.001)
- A2 DC Bias R/C Adjustment (Opt.001)

NOTE

It is necessary to perform the system backup after performing the adjustment so that the system recovery can be performed correctly. For details, refer to “System Backup (for serial prefix JP1KH, JP2KH, and MY432)” on page 147

Adjustment Adjustment Program

Spot Adjustment

Spot Adjustment executes the corresponding adjustment automatically according to replaced each analog board. Perform the Spot Adjustment when the analog board such as A1,A2,A3,A4,A5 or A6 board is replaced. For example, if you replace or adjustment only A1 board, perform only A1 Adjustment. For details, refer to Table 3-2 on page 122

Spot Adjustment consists of the following adjustments.

- A1 Adjustment

If you replace or adjust A1 Board, perform A1 Adjustment only.

The A1 Adjustment consists of the following adjustments.

- A1 VCXO Frequency Adjustment
- A3 Local Level Adjustment
- A3 Output AGC Gain Adjustment
- A3 Output Level Adjustment
- A4 Local AGC Gain Adjustment
- A4 Local Level Adjustment
- A4 IF Gain Adjustment
- Default Cal Coefficient Adjustment

- A3 Adjustment

If you replace or adjust A3 Board(or the Standard Test Head), perform A3 Adjustment only.

The A3 Adjustment consists of the following adjustments.

- A3 Local Level Adjustment
- A3 Output AGC Gain Adjustment
- A3 Output Level Adjustment
- A4 Local AGC Gain Adjustment
- A4 Local Level Adjustment
- A4 IF Gain Adjustment
- Default Cal Coefficient Adjustment

NOTE

If your instrument has an option 001(A2 DC Bias), perform A2 Adjustment after performing the A3 Adjustment.

- A4 Adjustment

If you replace or adjust A4 Board, perform A4 Adjustment only.

The A4 Adjustment consists of the following adjustments.

- A4 Local AGC Gain Adjustment
- A4 Local Level Adjustment
- A4 IF Gain Adjustment

— Default Cal Coefficient Adjustment

NOTE

If your instrument has option 001(A2 DC Bias), perform A2 Adjustment after performing the A4 Adjustment.

- A5 Adjustment (Opt.1D5)

If you replace or adjust A5 Board, perform A5 Adjustment only.

The A5 Adjustment consists of the following adjustment.

— A5 Ref Oven Adjustment (Opt.1D5)

- A2 Adjustment (Opt.001)

If you replace or adjust A2 Board, perform A2 Adjustment only.

The A2 Adjustment consists of the following adjustments.

— A2 DC Bias Voltage Adjustment (Opt.001)

— A2 DC Bias Current Adjustment (Opt.001)

— A2 DC Bias R/C Adjustment (Opt.001)

- Default Cal Adjustment

If you replace A1 or A3 or A4 Board, perform Default Cal Adjustment.

The Default Cal Adjustment consists of the following adjustment.

— Default Cal Coefficient Adjustment

NOTE

It is necessary to perform the system backup after performing the adjustment so that the system recovery can be performed correctly. For details, refer to “System Backup (for serial prefix JP1KH, JP2KH, and MY432)” on page 147

Write ID

Write ID executes writing the serial number and the option information. Perform this procedure whenever you replace EEPROM with new one. This process can not be performed without inputting a password. This password is “ctuKobe”.

EEPROM Initialize

EEPROM Initialize executes initializing the EEPROM. When you replace EEPROM with new one, perform this procedure. All Adjustment must be performed after performing this item. This item is included in the “All Adjustment”.

Adjustment
Adjustment Program

How to perform the Adjustment Program

The following is the simple procedure to perform the Adjustment Program. For details, refer to the “Operation Manual for E4991A Adjustment Program”.

Step 1. If the following equipment is used for the E4991A Adjustment, you need to use Agilent Edit Cal(Calibration Data Editor).

If you don't use the following equipment, go to step 3.

- 8482A Power Sensor

Install the latest version: Rev.A.02.30(as of November 2001)of Agilent Edit Cal before running the Adjustment Program, if it is not installed in your PC. For details, refer to “Operation Manual for Edit Cal”. The program and operation manual for the Edit Cal are downloadable from CTU-Kobe web site.

Step 2. Enter the calibration data of the Equipment(8482A) in the Edit Cal.

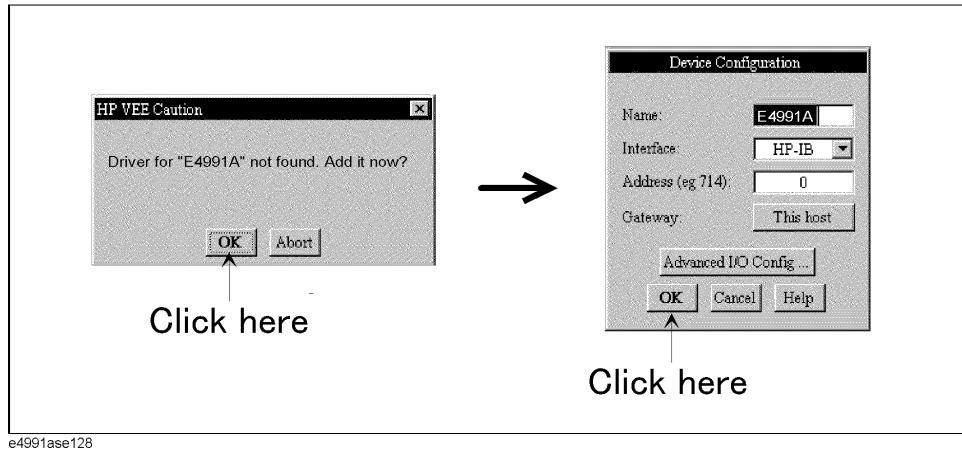
Step 3. Start the Agilent VEE.

Step 4. Load the adjustment program file into the Agilent VEE as follows.

1. Pull down the File menu from the Agilent VEE window and select **Open**.
2. Select the file C:\adje4991a\adje4991a.vee and click **Open**.

Step 5. You may be asked to add drivers for the equipment during the program loading. Then, click **OK** and the GPIB address for each equipment. Enter 0 as the address for the equipment which are not used for the adjustment. (See Figure 3-4).

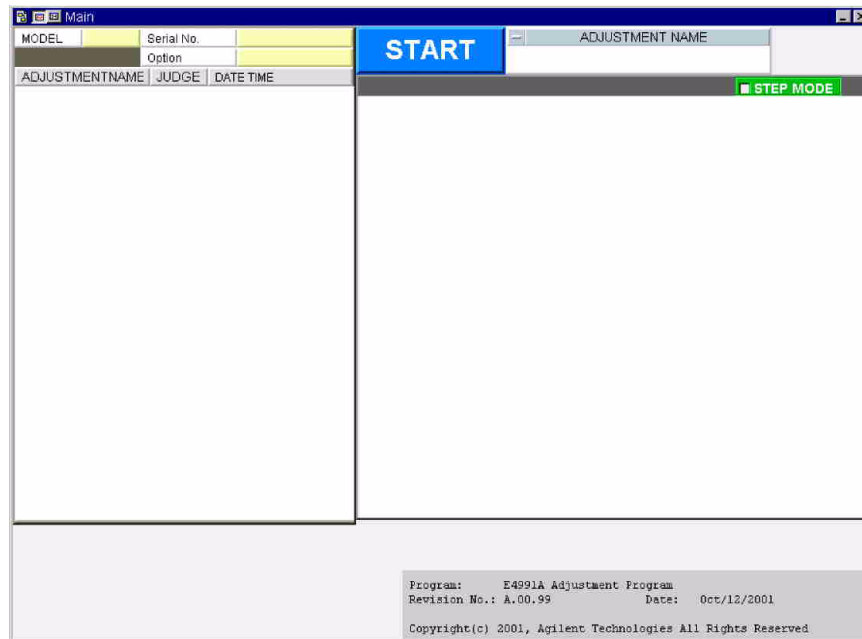
Figure 3-4 Direct I/O configuration



Step 6. Click **START** on the Agilent VEE Screen as shown in Figure 3-5.

Figure 3-5

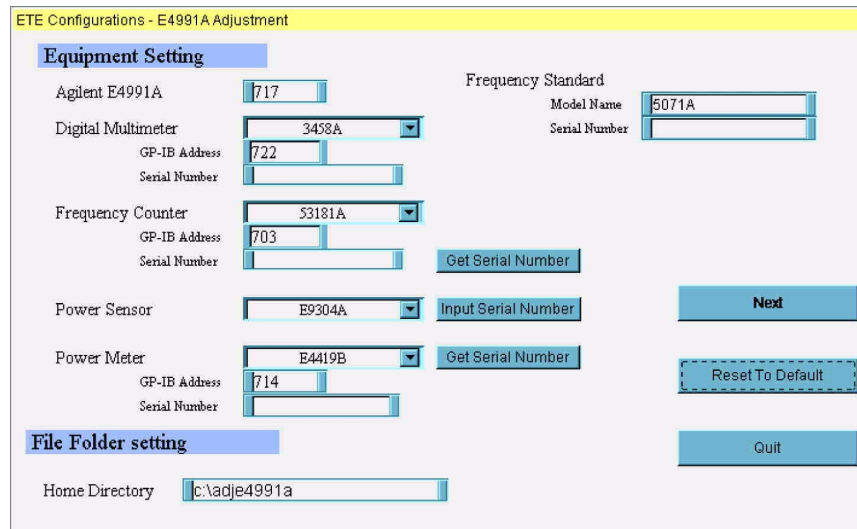
Agilent VEE Screen



Step 7. “ETE Configuration” box is displayed as show in Figure 3-6. Select the model number and the serial number of the equipment and set its GPIB address. In File Folder Setting, enter the path the Adjustment Program installed. Click **Next**, when you complete the settings.

Figure 3-6

ETE Configuration



Step 8. “E4991A Info and Adjustment Conditions” box is displayed as shown in Figure 3-7. Input the E4991A serial number, option and the test conditions. Generally, use the 16195B Calibration Kit which is a furnished accessory for the E4991A. Click **Next**, when you complete the settings.

Adjustment Adjustment Program

Figure 3-7

E4991A Info and Adjustment Conditions

E4991A Info and Adjustment Conditions

MODEL

E4991A Serial Number and Option

MainFrame

Test Head

Calibration Kit

Options 001 1D5 002

Adjustment Conditions

Adjusted By

Customer Name

Date

Temperature DEG C

Humidity %

Report Number

Comment

NEXT STEP **QUIT PROGRAM**

Step 9. “Adjustment Program Main Menu” box is displayed as shown in Figure 3-8. For example, click **[F1]All Adjustment**, if you want to perform all adjustments.

Figure 3-8

Adjustment Program Main Menu

Adjustment Program Main Menu

[F1]All Adjustment

[F3]Spot Adjustment

[F5] Write ID

[F6] EEPROM Initialize

[F9] Input Environment Data

[F12]Program End

When the Spot Adjustment is selected in Main Menu, “Spot Adjustment Menu” box is displayed as shown in Figure 3-9. Then select the corresponding adjustment according to Table 3-2 on page 122.

Figure 3-9

Spot Adjustment Menu

Select - Spot Adjustment -

A1 Adjustment	A5 Adjustment(Opt.1D5)
A3 Adjustment	A2 Adjustment(Opt.001)
A4 Adjustment	
Default Cal Adjustment	Cancel

Information

If you replace or adjust A1 board, perform A1 Adjustment.
If you replace or adjust A3 board, perform A3 Adjustment and A2 Adjustment(Opt.001).
If you replace or adjust A4 board, perform A4 Adjustment and A2 Adjustment(Opt.001).
If you replace or adjust A2 board, perform A2 Adjustment(Opt.001).
If you replace or adjust A5 board, perform A5 Adjustment(Opt.1D5).
If you replace the Standard Test Head, perform A3 Adjustment and A2 Adjustment(Opt.001)

For more detailed adjustment procedure, refer to the chapter of Adjustment or Post Repair Procedure in the Service Manual.

Initialization of the System Calibration Data

The EEPROM has the system calibration data. When the EEPROM on the A21 Analog Interface Board is replaced, it is necessary to initialize the EEPROM using the “EEPROM Initialize” in the Adjustment Program. All Adjustment must be performed after performing this item. This item is included in the “All Adjustment”. When you encounter the error regarding the EEPROM such as “EEPROM TEST:Fail” or “EEPROM CSUM ERROR”, firstly perform this item to disappear it.

Required Equipment

Nothing

Procedure

- Step 1.** Run the adjustment program.
- Step 2.** Choose the EEPROM Initialize in the Main Menu.
It is possible to perform this item with the All Adjustment too.
- Step 3.** Make sure that nothing is connected to the E4991A.
- Step 4.** Follow the adjustment program instruction to update the correction constant.

NOTE

All Adjustment must be performed after performing this item.

A1 VCXO Frequency Adjustment

The purpose of this procedure is to adjust the VCXO on the A1 Reference Oscillator Board.

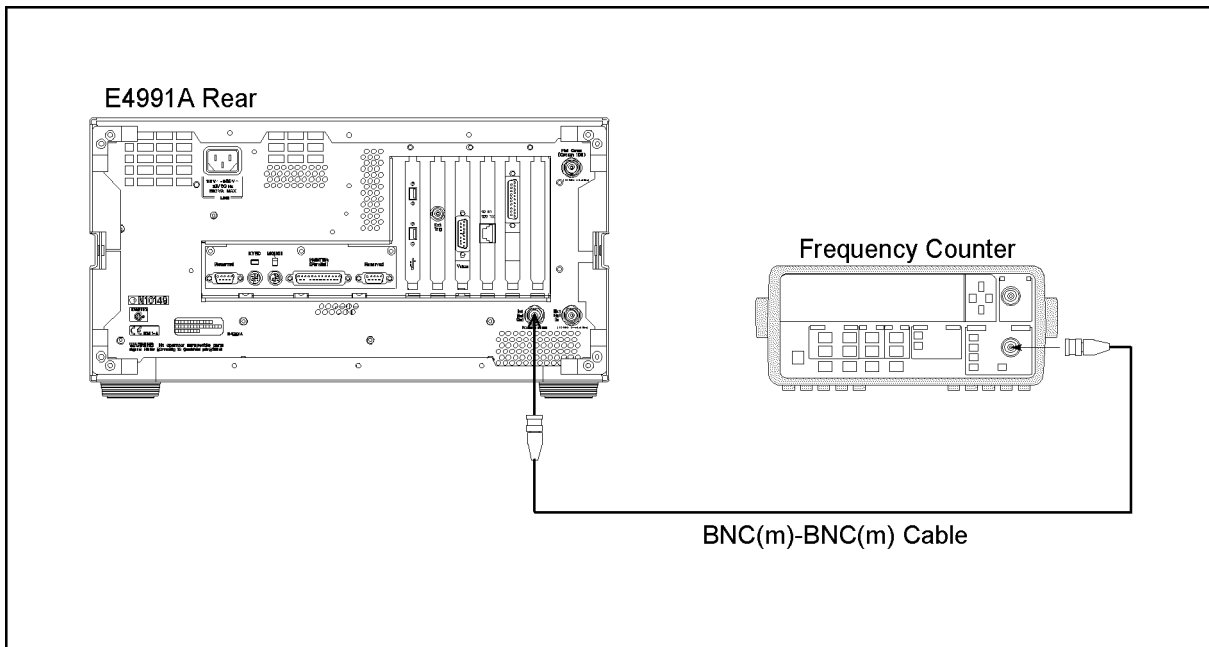
Required Equipment

Description	Recommended Model
Frequency Counter	53181A Opt.010 and 030, 53131A Opt.010 and 030 or 53132A Opt.010 and 030
BNC(m)-BNC(m) Cable, 61 cm	p/n 8120-1839

Procedure

- Step 1.** Run the adjustment program.
- Step 2.** Choose the A1 Adjustment in the Spot Adjustment.
It is possible to perform this item with the All Adjustment too.
- Step 3.** Make sure that nothing is connected to the “Ext Ref In” on the E4991A rear panel.
- Step 4.** Connect the instrument as shown in Figure 3-10

Figure 3-10 A1 VCXO Frequency Adjustment Setup



e4991ase010

- Step 5.** Follow the adjustment program instruction to update the correction constant.

A3 Local Level Adjustment

The purpose of this procedure is to adjust the local level on the A3 Source Board.

Required Equipment

Nothing

Procedure

- Step 1.** Run the adjustment program.
- Step 2.** Choose the A3 Adjustment in the Spot Adjustment.
It is possible to perform this item with the All Adjustment too.
- Step 3.** Make sure that nothing is connected to the E4991A.
- Step 4.** Follow the adjustment program instruction to update the correction constant.

A3 Output AGC Gain Adjustment

The purpose of this procedure is to adjust the gain of AGC on the A3 Source Board.

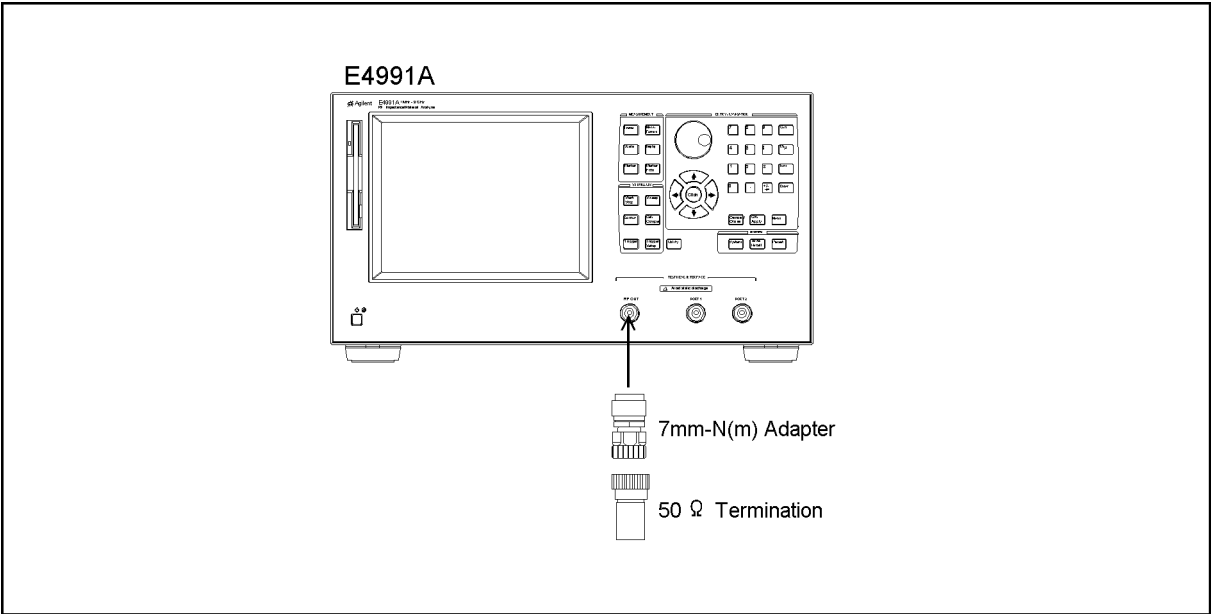
Required Equipment

Description	Recommended Model
Calibration Kit	16195B(furnished with E4991A)
7mm-N(m) Adapter	11525A

Procedure

- Step 1.** Run the adjustment program.
- Step 2.** Choose the A3 Adjustment in the Spot Adjustment.
It is possible to perform this item with the All Adjustment too.
- Step 3.** Connect the instrument as shown in Figure 3-11.

Figure 3-11 A3 AGC Gain Adjustment Setup



e4991ase016

- Step 4.** Follow the adjustment program instruction to update the correction constant.

A3 Output Level Adjustment

The purpose of this procedure is to adjust the A3 output level and flatness.

Required Equipment

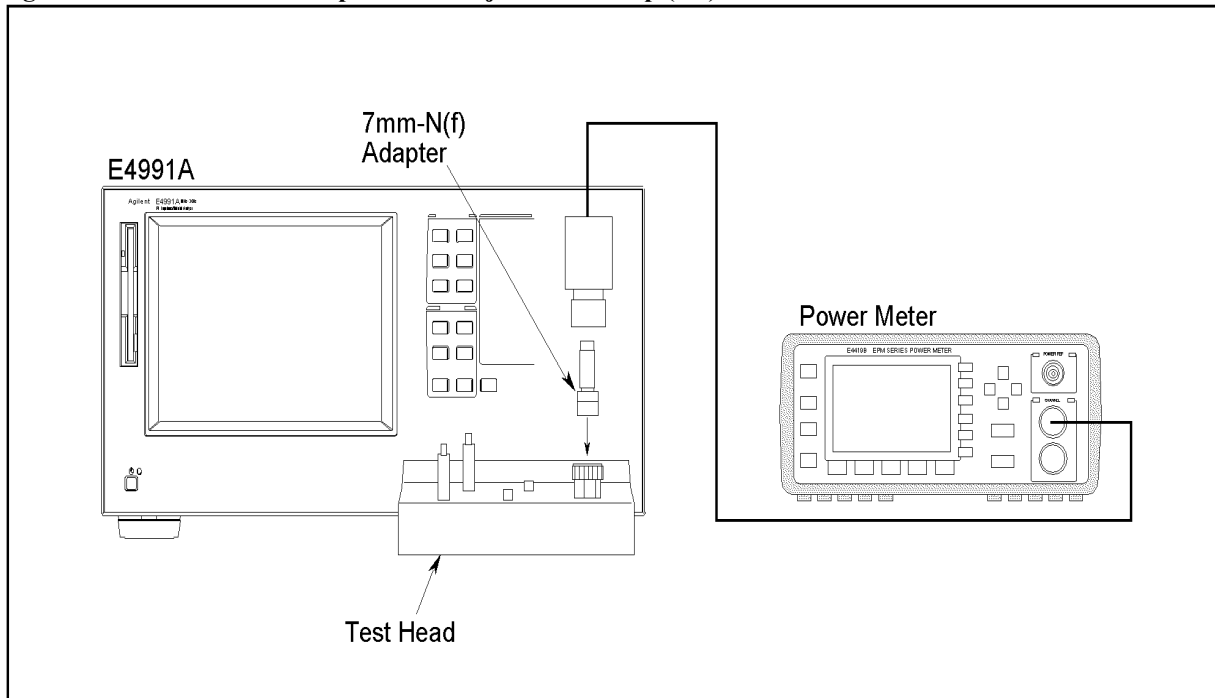
Description	Recommended Model
Power Meter	438A, E4418A/B or E4419A/B
Power Sensor	8482A+8481D or E9304A *1
Calibration Kit	16195B
7mm-N(f) Adapter	11524A

*1. The E9304A cannot be used with the 438A.

Procedure

- Step 1.** Run the adjustment program.
- Step 2.** Choose the A3 Adjustment in the Spot Adjustment.
It is possible to perform this item with the All Adjustment too.
- Step 3.** Connect the instrument as shown in Figure 3-12.

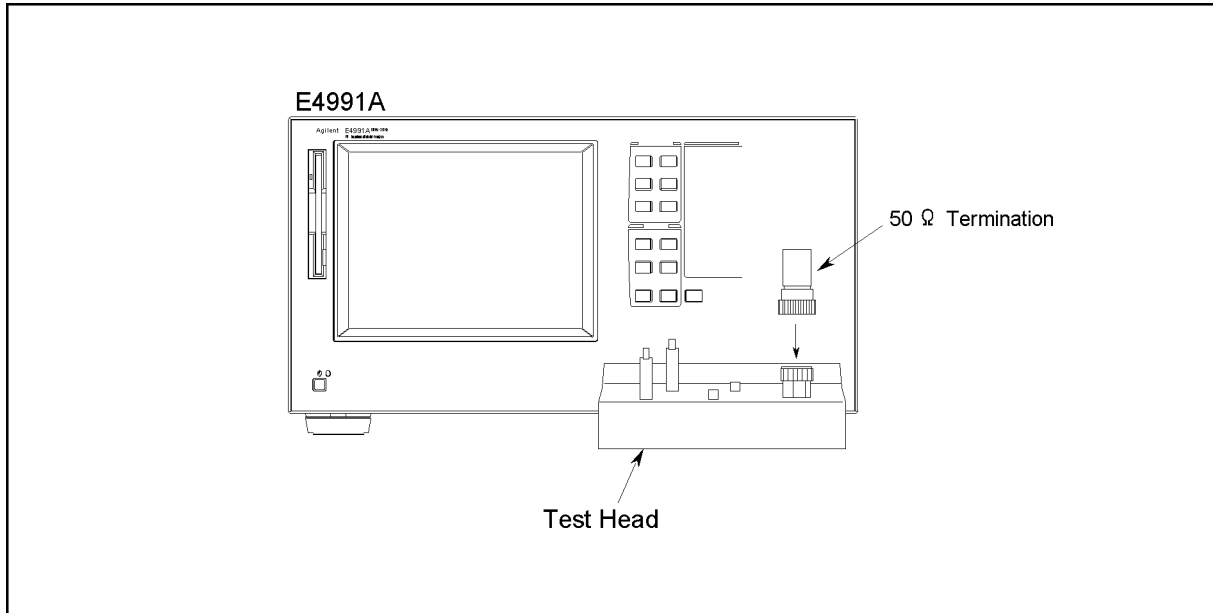
Figure 3-12 A3 Output Level Adjustment Setup (1/2)



e4991ase005

- Step 4.** Click OK, then wait till the measurement completion.
- Step 5.** Disconnect the power sensor and the adapter from the 7mm connector.
- Step 6.** Connect the instrument as shown in Figure 3-13.

Figure 3-13 A3 Output Level Adjustment Setup (2/2)



e4991ase009

- Step 7.** Follow the adjustment program instruction to update the correction constant.

A4 AGC Gain Adjustment

The purpose of this procedure is to adjust the Gain of AGC on the A4 Receiver Board.

Required Equipment

Nothing

Procedure

- Step 1.** Run the adjustment program.
- Step 2.** Choose the A4 Adjustment in the Spot Adjustment.
It is possible to perform this item with the All Adjustment too.
- Step 3.** Make sure that nothing is connected to the E4991A.
- Step 4.** Follow the adjustment program instruction to update the correction constant.

A4 Local Level Adjustment

The purpose of this procedure is to adjust the local level in the A4 Receiver Board.

Required Equipment

Nothing

Procedure

- Step 1.** Run the adjustment program.
- Step 2.** Choose the A4 Adjustment in the Spot Adjustment.
It is possible to perform this item with the All Adjustment too.
- Step 3.** Make sure that nothing is connected to the E4991A.
- Step 4.** Follow the adjustment program instruction to update the correction constant.

A4 IF Gain Adjustment

The purpose of this procedure is to adjust the IF Gain in the A4 Receiver Board.

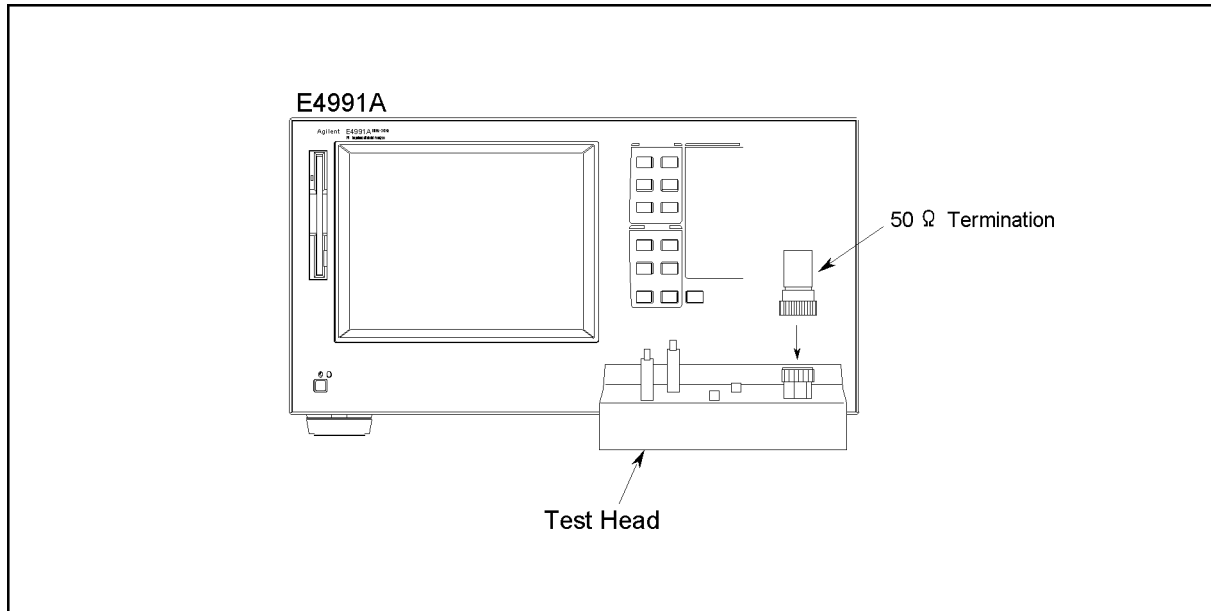
Required Equipment

Description	Recommended Model
Calibration Kit	16195B(furnished with E4991A)

Procedure

- Step 1.** Run the adjustment program.
- Step 2.** Choose the A4 Adjustment in the Spot Adjustment.
It is possible to perform this item with the All Adjustment too.
- Step 3.** Connect the instrument as shown in Figure 3-14.

Figure 3-14 A4 IF Gain Adjustment Setup



e4991ase009

- Step 4.** Follow the adjustment program instruction to update the correction constant.

Default Cal Coefficient Adjustment

The purpose of this procedure is to keep the default of the coefficient of calibration.

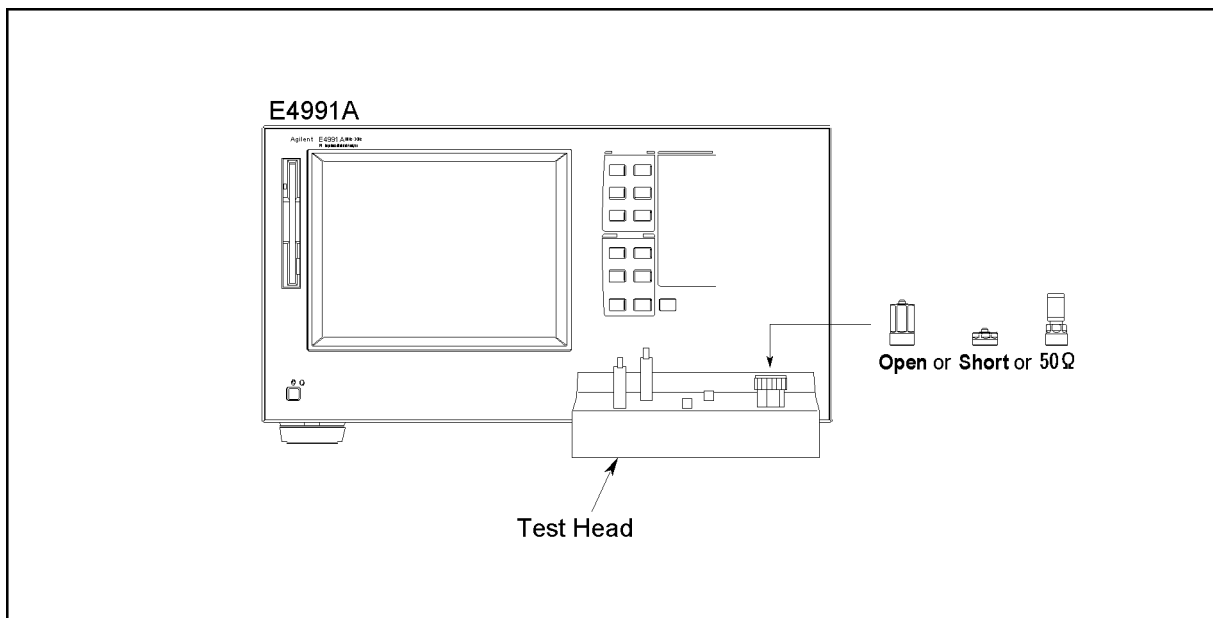
Required Equipment

Description	Recommended Model
Calibration Kit	16195B(furnished with E4991A)

Procedure

- Step 1.** Run the adjustment program.
- Step 2.** Choose the Default Cal Adjustment in the Spot Adjustment.
 It is possible to perform this item with the All Adjustment too.
- Step 3.** Connect the instrument as shown in Figure 3-15.

Figure 3-15 **Default Cal Coefficient Adjustment Setup**



e4991ase018

- Step 4.** Follow the adjustment program instruction to update the correction constant.

A5 Reference Oven Adjustment (Opt 1D5 only)

The purpose of this procedure is to adjust the 10MHz high stability reference oscillator (Option 1D5) frequency.

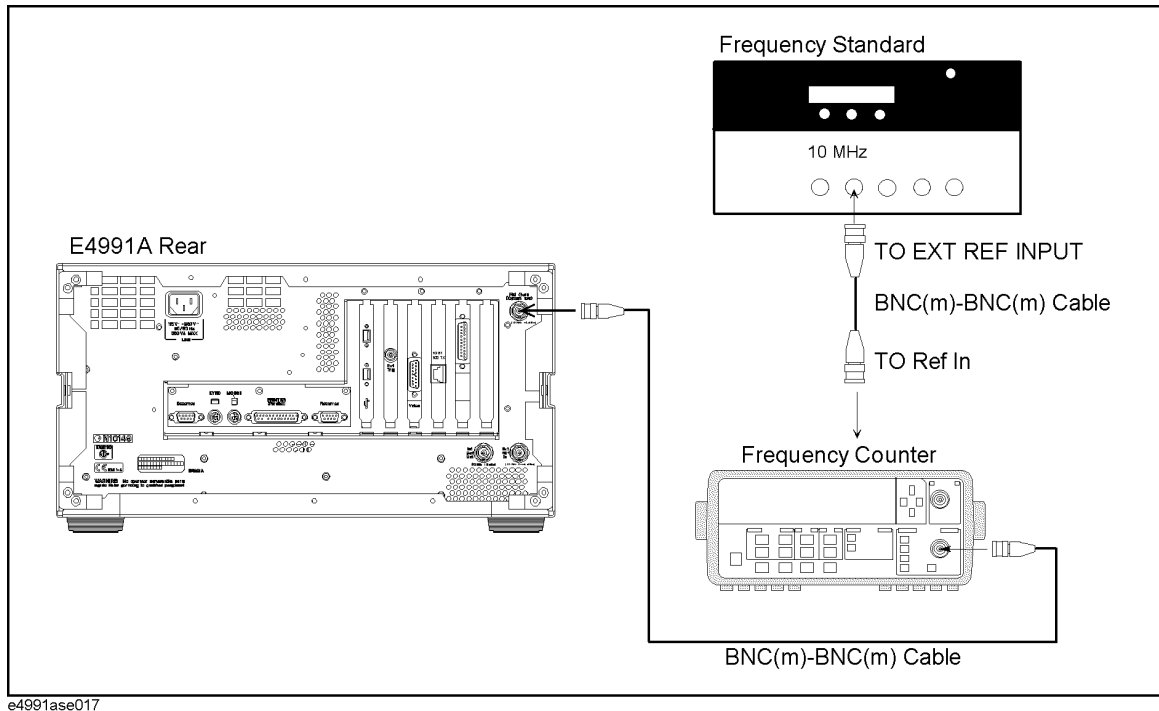
Required Equipment

Description	Recommended Model
Frequency Counter	53181A Opt.010 and 030, 53131A Opt.010 and 030 or 53132A Opt.010 and 030
Frequency Standard	5071A or 5061B
BNC(m)-BNC(m) Cable, 61 cm	p/n 8120-1839
BNC(m)-BNC(m) Cable,122cm	p/n 8120-1840

Procedure

- Step 1.** Run the adjustment program.
- Step 2.** Choose the A5 Adjustment (Opt .1D5) in the Spot Adjustment.
It is possible to perform this item with the All Adjustment too.
- Step 3.** Connect the instrument as shown in Figure 3-16.

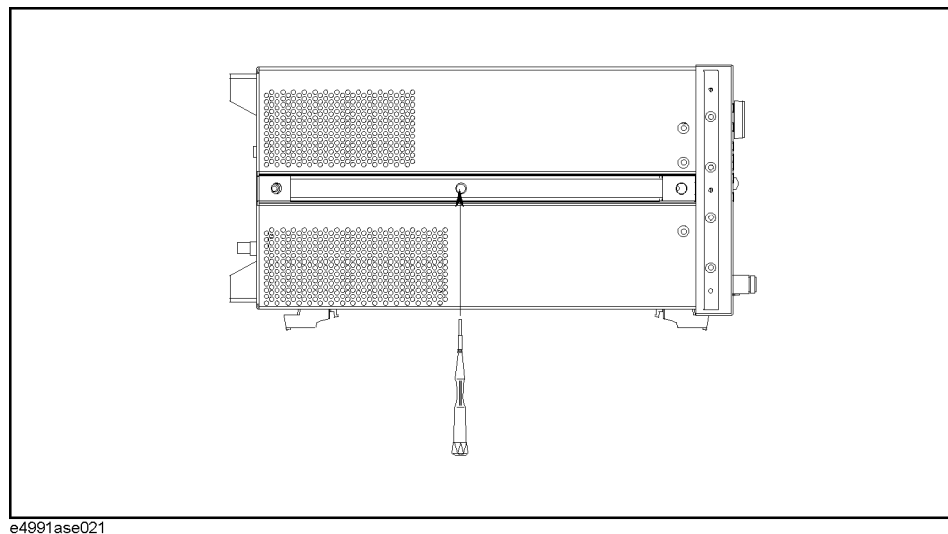
Figure 3-16 A5 Reference Oven Adjustment Setup



Step 4. Follow the adjustment program instruction to update the correction constant.

Step 5. Adjust “Reference Oven Adjustment screw” as shown in Figure 3-17 so that the counter reading is 10MHz +/- 1Hz, if the counter reading is out of 10MHz +/- 1Hz. Then remove side strap handle.

Figure 3-17 Reference Oven Adjustment Screw



A2 DC Bias Voltage Adjustment (Opt 001 only)

The purpose of this procedure is to adjust the output voltage and the voltage monitor on the A2 DC Bias Board.

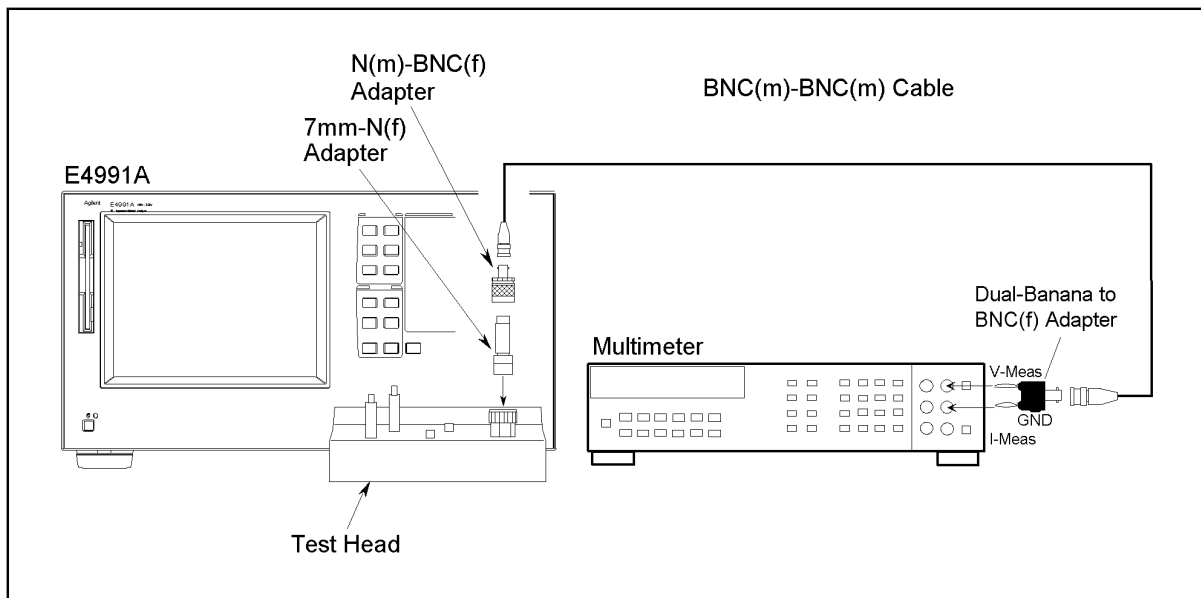
Required Equipment

Description	Recommended Model
Multimeter	3458A
7mm-N(f) Adapter	11524A
N(m)-BNC(f) Adapter	p/n 1250-0780
BNC(f)-Banana Adapter	p/n 1251-2277
BNC Cable, 61 cm	p/n 8120-1839

Procedure

- Step 1.** Run the adjustment program.
- Step 2.** Choose the A2 Adjustment (Opt .001) in the Spot Adjustment.
It is possible to perform this item with the All Adjustment too.
- Step 3.** Connect the instrument as shown in Figure 3-18.

Figure 3-18 A2 DC Bias Voltage Adjustment Setup



e4991ase014

- Step 4.** Follow the adjustment program instruction to update the correction constant.

A2 DC Bias Current Adjustment (Opt 001 only)

The purpose of this procedure is to adjust the output current and the current monitor on the A2 DC Bias Board.

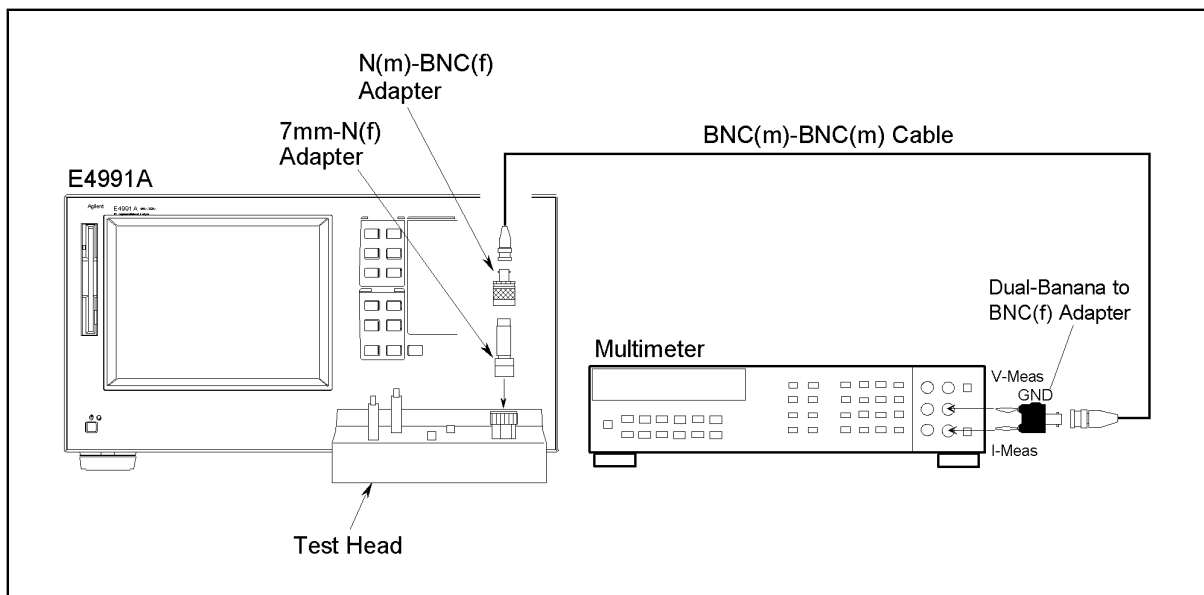
Required Equipment

Description	Recommended Model
Multimeter	3458A
7mm-N(f) Adapter	11524A
N(m)-BNC(f) Adapter	p/n 1250-0780
BNC(f)-Banana Adapter	p/n 1251-2277
BNC Cable, 61 cm	p/n 8120-1839

Procedure

- Step 1.** Run the adjustment program.
- Step 2.** Choose the A2 Adjustment (Opt . 001) in the Spot Adjustment.
It is possible to perform this item with the All Adjustment too.
- Step 3.** Connect the instrument as shown in Figure 3-19.

Figure 3-19 A2 DC Bias Current Adjustment Setup



e4991ase013

- Step 4.** Follow the adjustment program instruction to update the correction constant.

A2 DC Bias Output Resistor/Conductance Adjustment (Opt 001 only)

The purpose of this procedure is to get the output resistor and the output conductance on the A2 DC Bias Board.

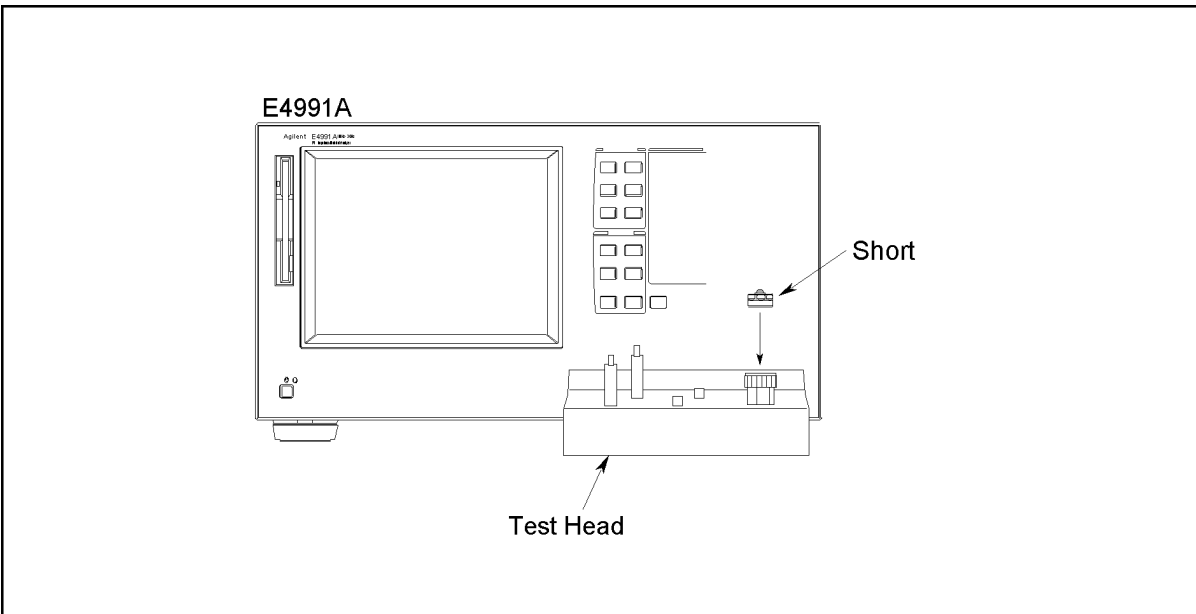
Required Equipment

Description	Recommended Model
Calibration Kit	16195B(furnished with E4991A)

Procedure

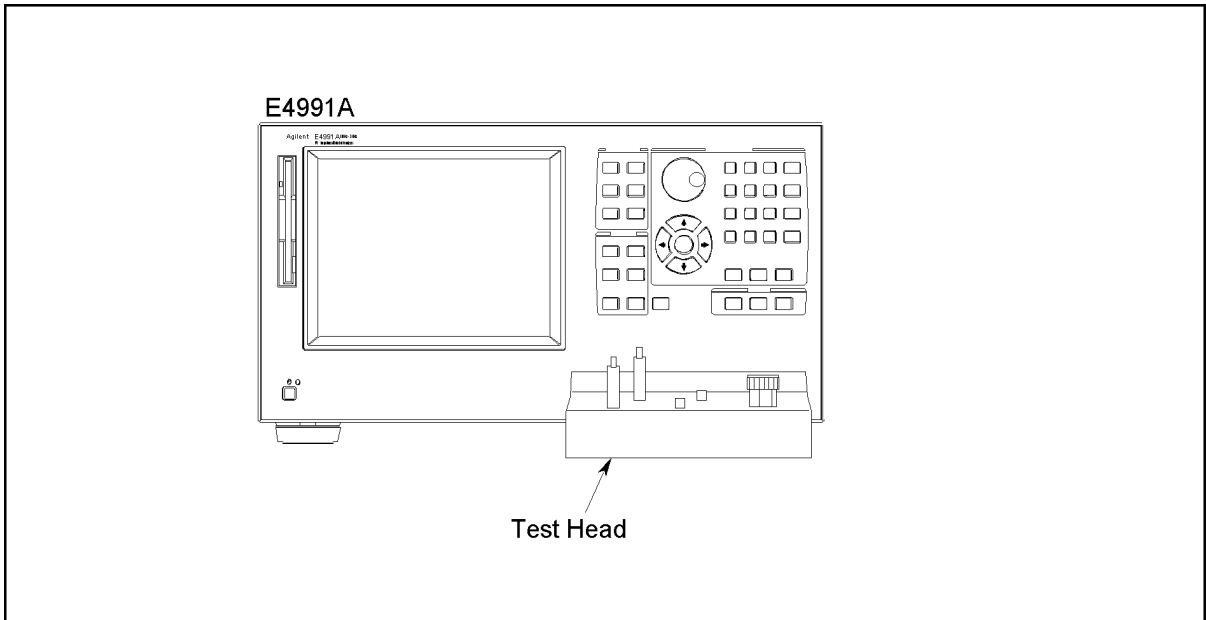
- Step 1.** Run the adjustment program.
- Step 2.** Choose the A2 Adjustment (Opt .001) in the Spot Adjustment.
It is possible to perform this item with the All Adjustment too.
- Step 3.** Connect the instrument as shown in Figure 3-20 and Figure 3-21.

Figure 3-20 A2 DC Bias Output R/C Adjustment Setup (1/2)



e4991ase019

Figure 3-21 A2 DC Bias Output R/C Adjustment Setup (2/2)



e4991ase020

Step 4. Follow the adjustment program instruction to update the correction constant.

Writing the Instrument ID

The E4991A has an instrument ID such as a serial number and an option number in the EEPROM. When the option configuration is changed or the EEPROM on the A21 Analog Interface Board is replaced, it is necessary to re-write the instrument ID using the “Write ID” in the Adjustment Program.

Required Equipment

Nothing

Procedure

- Step 1.** Run the adjustment program.
- Step 2.** Choose `Write ID` in the Main Menu.
- Step 3.** Make sure that nothing is connected to the E4991A.
- Step 4.** Follow the adjustment program instruction to re-write instrument ID in EEPROM. This process can not be performed without inputting a password. This password is “ctuKobe”.

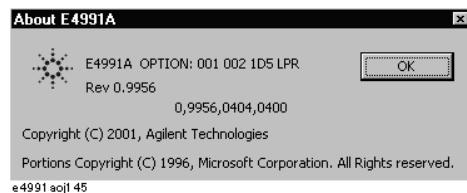
How to confirm the E4991A option installed

You can know the E4991A option number and firmware revision by the following E4991A mouse procedure.

- Step 1.** Click **System...** on the E4991A **System** menu.
- Step 2.** Click **About E4991A...**, and then About E4991A dialog box as shown in Figure 3-22 will be open.

Figure 3-22

About E4991A dialog box



- Step 3.** The E4991A option number and firmware revision are appeared in the dialog box.

Or, by the following E4991A front panel procedure.

- Step 1.** Press **[System]** key on the E4991A front panel.
- Step 2.** Move the cursor to **About E4991A...** using the arrow key, and press **[Click]** key on the front panel.
- Step 3.** The E4991A option number and firmware revision is displayed in the dialog box.

System Backup (for serial prefix JP1KH, JP2KH, and MY432)

The E4991A has the system files, application files and correction constant data in the C drive of the hard disk. The E4991A also has a backup file in the H drive (Hidden Drive) of the hard disk drive which includes a compression image of the system files, application files, and correction constant data. The System Backup copies the system files, application files and correction constant data in the C drive to the H drive. The correction constant data in the C drive and the EEPROM is updated to new data after performing the adjustment at the same time. It is necessary to perform the System Backup after performing the adjustment so that the System Recovery can be performed correctly. The procedure to perform the System Backup is as follows.

NOTE

The System Backup must be performed by manual after performing the Adjustment. The Adjustment Program can't perform System Backup.

How to make a system backup disk

- Step 1.** Copy the files (copydisk.exe, Backup.bin) which is downloadable from CTU-Kobe web site to the specific directory on the PC.
- Step 2.** Insert a floppy disk in the floppy disk drive of the PC.
- Step 3.** Run the DOS prompt, and change the current directory to the specific directory which includes the above two files.
- Step 4.** Perform the following command. Then, the system backup disk will be made automatically.

“copydisk.exe backup.bin a:“

System backup Procedure

- Step 1.** Connect the external keyboard with the E4991A.
- Step 2.** Insert the above system backup disk in the floppy disk drive of the E4991A.
- Step 3.** Power on E4991A.
- Step 4.** Press **[F]** key on the external keyboard as soon as the AMI BIOS System Configuration Display as shown in Figure 3-23 is displayed after RAM counting.

Figure 3-23

AMIBIOS System Configuration Display

AMIBIOS System Configuration (C) 1985-1997, American Megatrends Inc.,							
Main Processor	:	AMD-K6-2-/400		Base Memory Size	:	640KB	
Math Processor	:	Built-In		Ext. Memory Size	:	64512KB	
Floppy Drive A:	:	1.44 MB 3 1/2"		Display Type	:	VGA/EGA	
Floppy Drive B:	:	None		Serial Port(s)	:	3F8, 2F8	
AMIBIOS Date	:	07/15/95		Parallel Port(s)	:	378	
External Cache	:	512KB,Disabled		Power Management	:	APM, SMI	
ATA(PI) Device(s)	Type	Size		LBA Mode	32Bit Mode	Block Mode	PIO Mode
Primary Master	: Hard Disk	8064MB		LBA	Off	16Sec	4
PCI Devices:							
PCI Onboard Bridge Device				PCI Onboard USB Controller, IRQ9			
PCI Onboard IDE				PCI Slot 1 Ethernet, IRQ10			
PCI Slot 2 VGA				PCI Slot 3 Unknown Device, IRQ11			

e4991ase069

The contents of the system backup disk are loaded while Figure 3-24 is displayed. After a short time, the system backup start screen as shown in Figure 3-25 is displayed.

Figure 3-24

Searching File Display

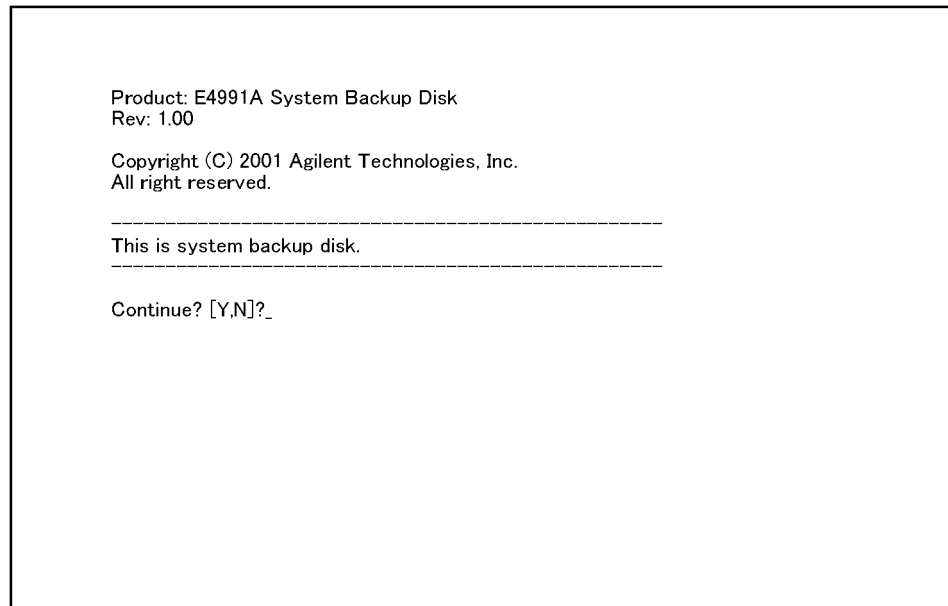
AMIBIOS System Configuration (C) 1985-1997, American Megatrends Inc.,							
Main Processor	:	AMD-K6-2-/400		Base Memory Size	:	640KB	
Math Processor	:	Built-In		Ext. Memory Size	:	64512KB	
Floppy Drive A:	:	1.44 MB 3 1/2"		Display Type	:	VGA/EGA	
Floppy Drive B:	:	None		Serial Port(s)	:	3F8, 2F8	
AMIBIOS Date	:	07/15/95		Parallel Port(s)	:	378	
Power Management	:	APM,SMI					
ATA(PI) Device(s)	Type	Size		LBA Mode	32Bit Mode	Block Mode	PIO Mode
Primary Master	: Hard Disk	8064MB		LBA	Off	16Sec	4
PCI Devices:							
PCI Onboard Bridge Device				PCI Onboard USB Controller, IRQ9			
PCI Onboard IDE				PCI Slot 1 Ethernet, IRQ10			
PCI Slot 2 VGA				PCI Slot 3 Unknown Device, IRQ11			

Searching for Boot Record from Floppy..OK

e4991ase070

Figure 3-25

System Backup Start Screen



e4991ase068

Step 5. Press **[Y]** key on keyboard in the following case.

Continue? [Y,N]? Y

A Backup file is already exist, Overwrite? [Y,N]? Y

Step 6. Remove the system backup disk from the floppy disk drive after confirming the following display.

DONE

A:\>

A:\> is indicated on the screen when the system backup is complete.

NOTE

You can confirm if the system backup is complete by the following procedure.

A:\> C:

C:\> dir /a

Then, confirm the file size and the time stamp of the following two files.

1. drvspace.000

2. sysbak.dat (the same file size, and the time stamp is the present.)

Step 7. Shut down the E4991A by pressing the power switch.

Step 8. The E4991A will restart in the system backup complete condition.

NOTE

System backup can be suspended without execution by pressing **[N]** instead of **[Y]** Step 5. A:\> is also indicated on the screen after this section is made. Remove the system backup

Adjustment

System Backup (for serial prefix JP1KH, JP2KH, and MY432)

_____ disk and shut down the E4991A by pressing the power switch.

4 Troubleshooting

This chapter provides procedure to isolate the failure assembly in the E4991A RF Impedance/Material Analyzer.

Introduction

WARNING These servicing instructions are for use by qualified personnel only. To avoid electrical shock, do not perform any servicing unless you are qualified to do so.

WARNING The opening of covers or removal of parts is likely to expose dangerous voltages. Disconnect the instrument from its power supply.

CAUTION Many of the assemblies in this instrument are very susceptible to damage from ESD (electrostatic discharge). Perform the following procedures only at a static-safe workstation and wear a grounding strap.

CAUTION Do NOT operate without following instructions. Programs or files in the instrument may be broken.

How to exit from the E4991A Measurement View

You need to exit from the E4991A Measurement View to perform the some troubleshooting. The following is the procedure to exit from the E4991A Measurement View.

- Step 1.** Connect the mouse and the external keyboard to the E4991A. Then turn on the E4991A.
- Step 2.** Click **System - Exit** from the menu bar. This opens the **Enter Password to exit** dialog box as shown in Figure 4-1.

Figure 4-1

Enter Password to exit dialog box



e4991ase052

- Step 3.** Enter the password: **e4991a** into the **Password** box by using the Enter Password to exit dialog box that appears by clicking the **Keyboard...** button or by using the external keyboard.
- Step 4.** Exit from the E4991A Measurement View by clicking the **OK** button. Then windows desktop screen is displayed.

NOTE

You have to shut down the E4991A by the following procedure and turn on E4991A after exiting the E4991A Measurement View.

1. Click **Start - Shut Down...**
 2. Click the **Shut down** button in the **Shut Down Windows** dialog box to select it.
 3. Click the **OK** button.
-

To Troubleshoot the Instrument

The primary procedural tool in this section is the flowchart. The flowchart contains entire troubleshooting path from a failed instrument to a working one, and will direct you in an orderly manner through the possible failure symptoms. Reference letters on the flowcharts point to procedural steps that explain the brief instructions in the chart.

Primary Trouble Isolation

The action in the Primary Trouble Isolation are done without disassembling the E4991A.

Step 1. Perform power-up

About few minutes after the E4991A is turned on, the measurement view is displayed on the screen. The display on the screen should be similar to the Figure 4-13, “G: Measurement View,” on page 165.

Step 2. Check the display

If there is no display on the LCD after the E4991A is turned on, go to “No Display Troubleshooting” on page 156. If the E4991A stops in booting process in spite of the anything is displayed on the LCD, go to “Booting Process Troubleshooting (for serial prefix JP1KH, JP2KH, and MY432)” on page 159 or “Booting Process Troubleshooting (for serial prefix MY433 and later)” on page 166. The power on self test is performed once automatically after the E4991A measurement view is displayed. If power on self test fails, go to “Troubleshooting Using Internal Test” on page 170.

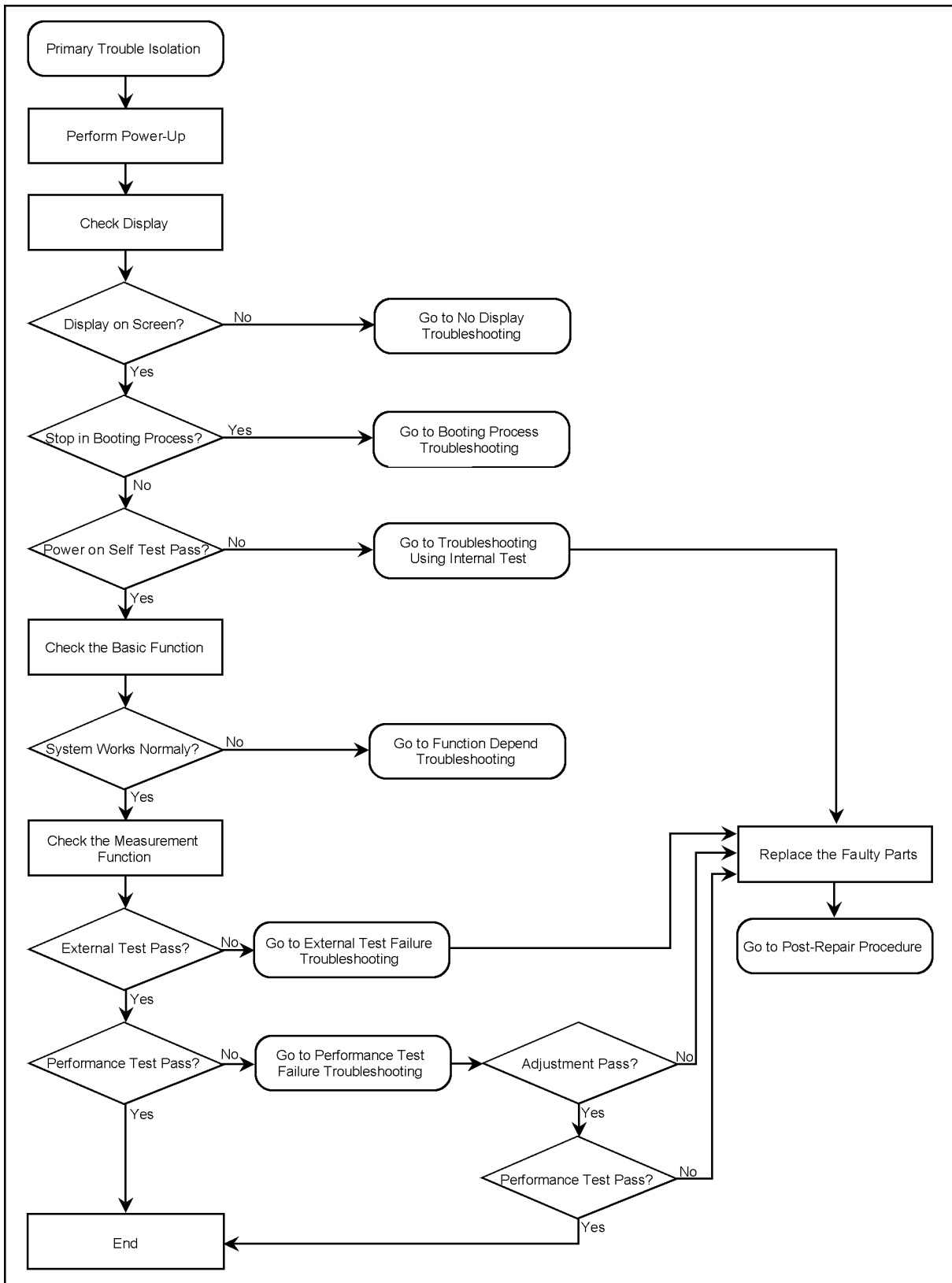
Step 3. Check the Basic Function

If you find the E4991A’s function without measurement part doesn’t work correctly, go to “Function Depend Troubleshooting” on page 173.

Step 4. Check the Measurement Function

If you find the measurement function doesn’t work correctly, perform the external test and the performance test. When the external test fails, go to “External Tests Failure Troubleshooting” on page 187. When the performance test fails, go to “Performance Tests Failure Troubleshooting” on page 194.

Figure 4-2 Primary Trouble Isolation Flowchart



e4991ase051

4. Troubleshooting

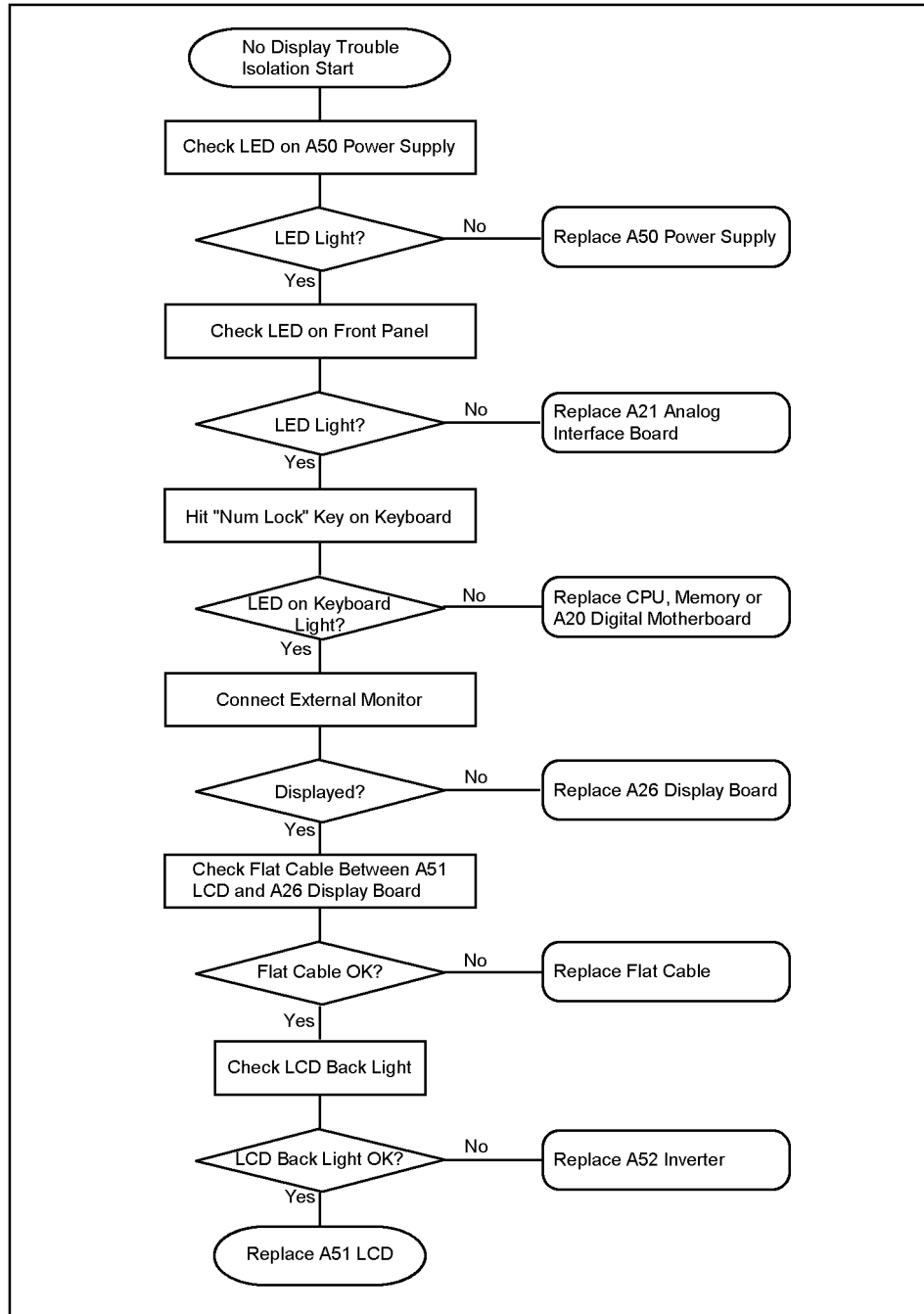
No Display Troubleshooting

If you encounter problems which there is no display, isolate the failure part in accordance with the following procedure.

Connect the keyboard to the E4991A rear, and turn the power on. And, start the trouble isolation.

Figure 4-3

No Display Trouble Isolation



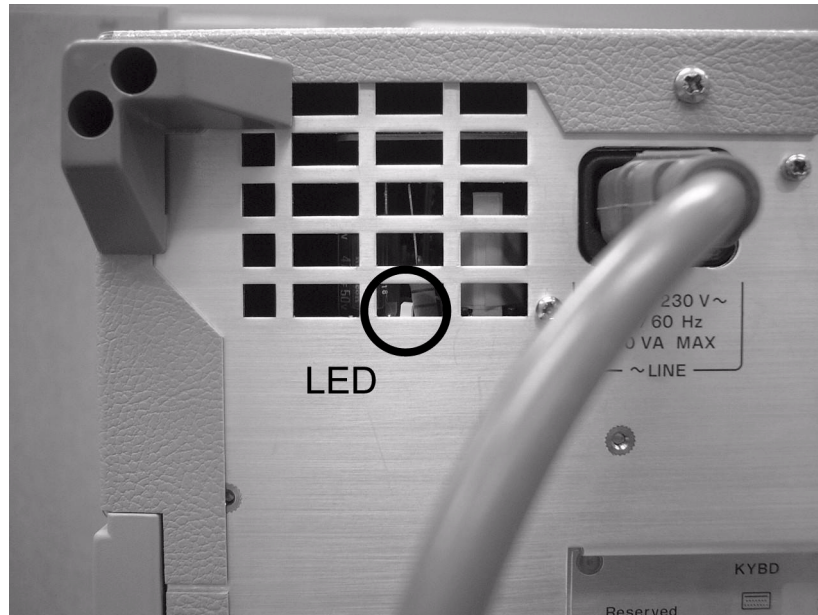
4287ase04012

Step 1. Check LED on A50 Power Supply

From the E4991A rear, check the LED inside of the lattice of the rear panel as shown in Figure 4-4. If the LED doesn't light, the A50 Power Supply assembly is failure.

Figure 4-4

LED on the A50 Power Supply



Step 2. Check power LED

If the power LED on Front Panel doesn't light and the fans inside of the E4991A doesn't run, problem seems in the A21 Analog Interface board or the flat cable between the A21 and the A22 Front Panel Keyboard.

If power shutdown occurs immediately after the power LED lights, there is a possibility that the fan stops. The E4991A has three fans inside. There is one CPU fan on the A20 Digital Motherboard. There are two system fans which are secured on the frame. A power shutdown occurs the moment the system fans stops. In this case, remove the E4991A outer cover and make sure whether the fans run or stop.

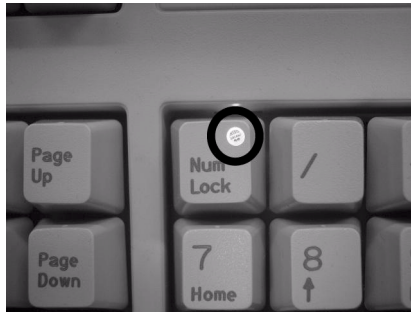
Troubleshooting
No Display Troubleshooting

Step 3. Check LED of “Num Lock” key

Hit the “Num Lock” key which is on the keyboard as shown in the Figure 4-5. If the LED doesn't light, problem seems in the CPU, DIMM (memory), or A20 Digital Motherboard.

Figure 4-5

LED of the Num Lock key



NOTE

Make sure of the followings before replacing the CPU, DIMM64MB, or A20.

- Whether CPU, DIMM64MB, and BIOS ROM on the A20 are connection good or not.
- Whether the jumpers setting on the A20 are correct or not as described in “Configure the Motherboard” on page 196.
- Whether BIOS options are correct or not as described in “To Confirm or Set the BIOS Options” on page 198.

Step 4. Checking with the external monitor

Connect an additional VGA monitor to the VIDEO output on the E4991A rear panel.

- If something is displayed on the external monitor, problem is around the LCD.
- If nothing is displayed even on the external monitor, problem seems in A26 Display board or around the A20 Digital Motherboard.

Step 5. Check Flat Cable

Check a flat cable between A51 LCD and A26 display board.

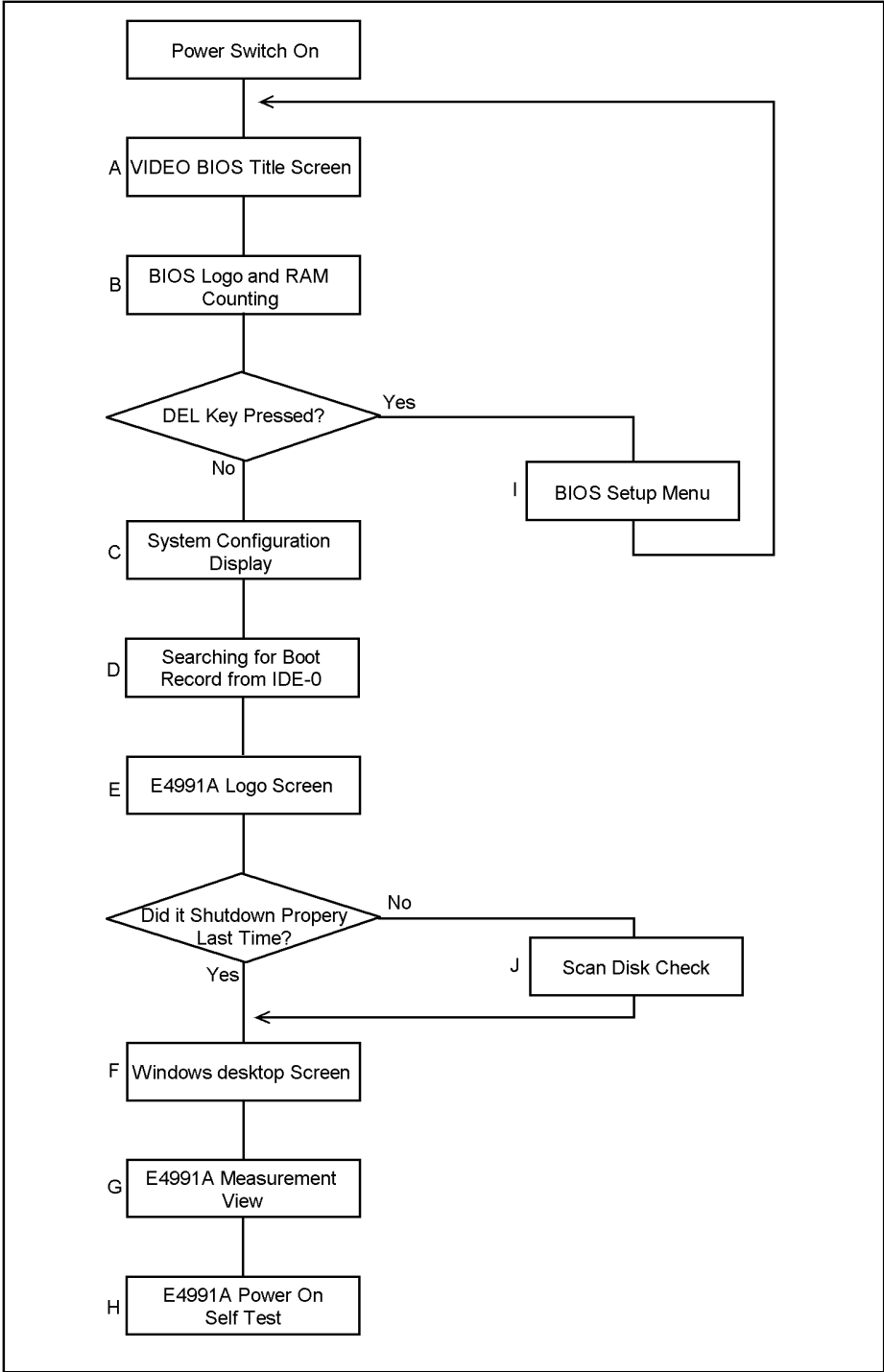
Step 6. Check around the Back Light

Check A52 inverter board and cable between A52 and A26 and cables between A51 LCD and A52.

Booting Process Troubleshooting (for serial prefix JP1KH, JP2KH, and MY432)

Figure 4-6

Booting Process



e4991ase033

Troubleshooting

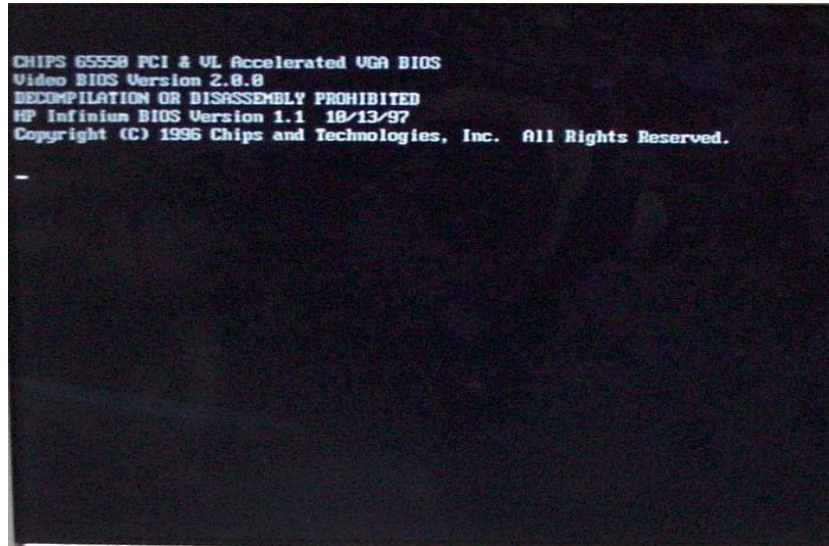
Booting Process Troubleshooting (for serial prefix JP1KH, JP2KH, and MY432)

Step 1. Video BIOS Boot

Video BIOS title screen shown in Figure 4-7 is displayed first, when the E4991A turned on. If the Video BIOS title screen doesn't displayed, go to "No Display Troubleshooting" on page 156.

Figure 4-7

A: Video BIOS Title Screen



Step 2. BIOS, RAM Counting

BIOS logo screen shown in Figure 4-8 describes the BIOS name, model number of the Digital Motherboard, CPU type and RAM size on the Digital Motherboard, and type of the Mass Storage.

If the message is displayed, you can assume that A20 Digital Motherboard, CPU and DIMM64MB are functioning correctly.

If the E4991A stops during checking RAM, you can assume problem is in the A20, or DIMM64MB.

NOTE

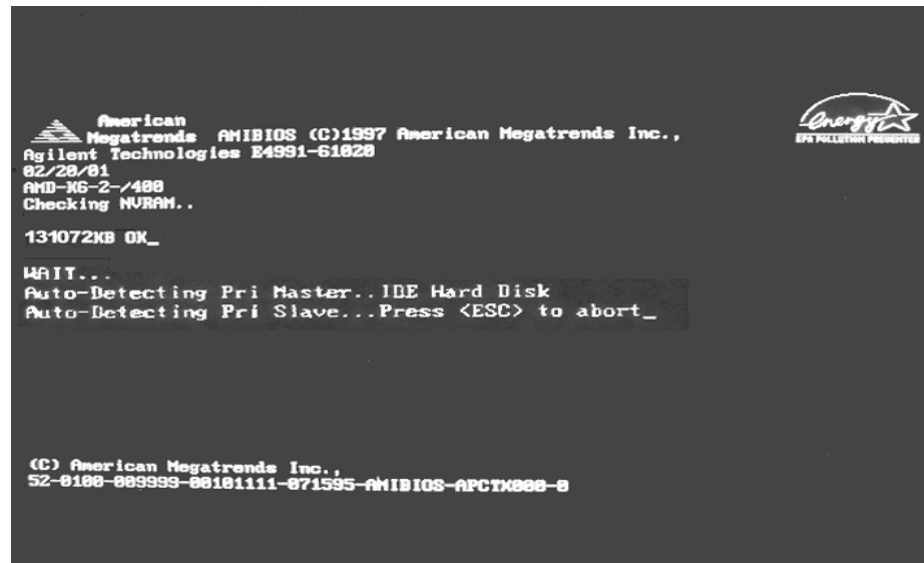
Hit **[Delete]** key on the external keyboard as soon as the message of "Hit DEL if you want to run SETUP" is displayed during RUM counting, if you want run the BIOS setup utility.

It is able to be the followings using the BIOS setup utility. For details of the BIOS options the E4991A is specified, refer to "To Confirm or Set the BIOS Options" on page 198.

- to set the system date and time
 - to change the first boot device (if you want to boot from floppy disk, it is necessary to change it.)
 - to confirm the BIOS options
-

Figure 4-8

B: BIOS Logo and RAM Counting

**Step 3.** System Configuration

The BIOS checks the E4991A configuration and displays it shown in as Figure 4-9. Three PCI boards, A21, A25, and A26 can be confirmed like below.

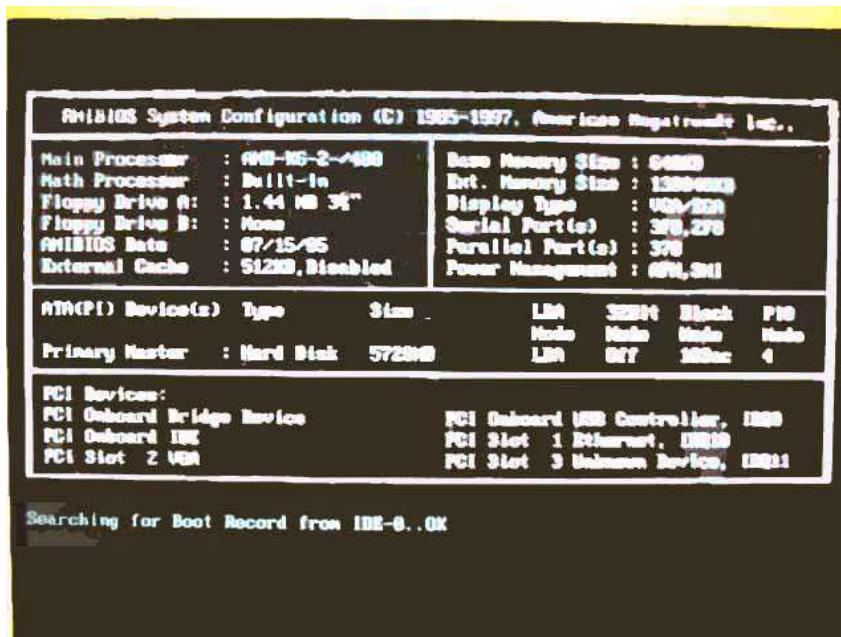
- “PCI Slot 1 : Ethernet” is A25 LAN board
- “PCI Slot 2 : VGA” is A26 Display board
- “PCI Slot 3 : Unknown Device” is A21 Analog Interface board

If the BIOS couldn’t detect above boards caused by hardware problem or poor connection, nothing is displayed there. In addition, the BIOS can not check the operation of the above boards. When nothing is displayed there, doubt first whether a PCI slot connection is poor or not.

But A24 GPIB board can’t be confirmed because it is on the ISA slots.

Figure 4-9

C: System Configuration

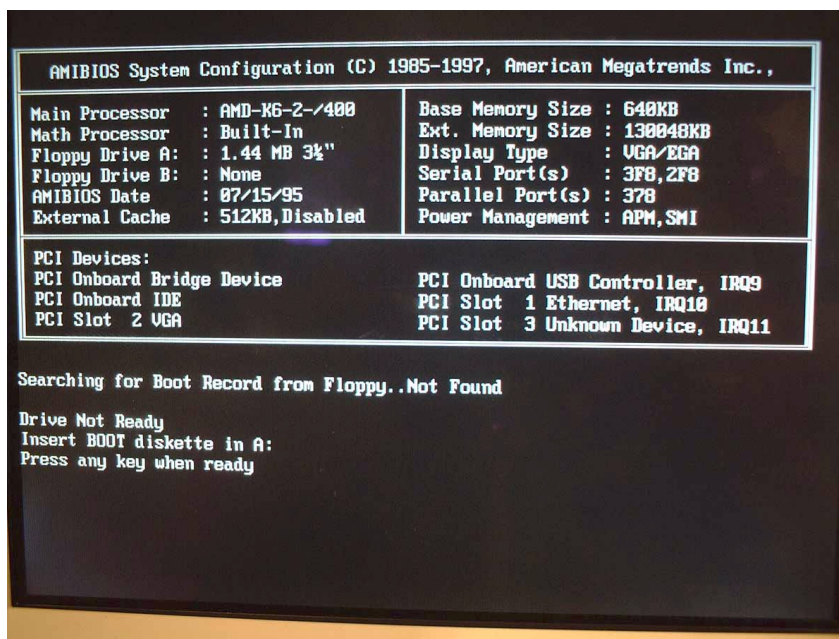


Step 4. Searching for Boot Record

A message of “Searching for Boot Record from IDE-0..OK” shown in Figure 4-9 is displayed after system configuration is displayed when the E4991A starts to boot from the A27 Mass Storage (IDE-0) without problem. However, a message of “Drive Not Ready” shown in Figure 4-10 is displayed when the E4991A could not boot from it. In this case, the E4991A may have a problem around the A27.

Figure 4-10

D: message of Hard Disk not ready



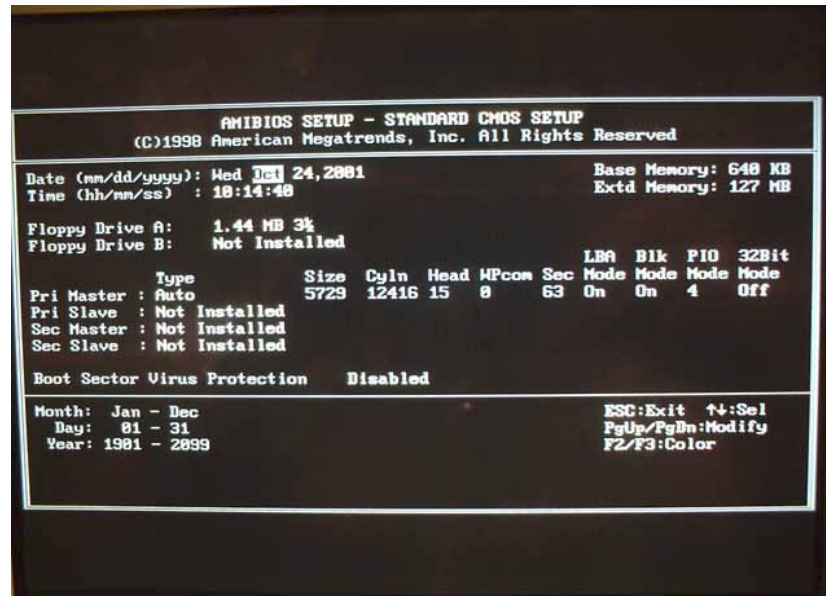
Booting Process Troubleshooting (for serial prefix JP1KH, JP2KH, and MY432)

You can check whether the A27 gives hardware problem or not using BIOS setup utility as shown in Figure 4-11. For details of how to run the BIOS setup utility, refer to “Run the BIOS setup utility” on page 198.

Move the cursor to “Auto-Detect Hard Disks” using [↑], [↓] keys and hit [Enter] key at the BIOS setup utility main menu. Then Figure 4-11 is displayed.

Figure 4-11

Auto-Detect Hard Disks page



The E4991A has an A27 (hard disk drive) which is connected to the IDE1 connector on the A20 Digital Motherboard. The disk size, cyln and so on are displayed as shown in the Figure 4-11 as soon as the mass storage is detected. If the mass storage is not detected, “Not Installed” is displayed on “Pri Master” right. In this case, check the flat cables first which are connected with the A27 and the A20 via the A26 Display board. If the flat cables are ok, replace the A27.

Step 5. E4991A Logo Screen

Files of the E4991A logos are in A27 Mass Storage. If the logos are displayed, the A27 works.

NOTE

If the E4991A was turned off without shutdown process, Microsoft Scandisk run after E4991A logo is displayed. If serious trouble is found in the scan disk, reinstall the operating system. For details of the system installation, refer to Appendix B, “System Installation for A27 Mass Storage,” on page 311. And if the operating system still doesn’t boot properly after reinstallation, A27 has to be replaced physically.

And, you encounter the following problems, try to reinstall the operating system before replacing the A27.

- “xxx file is missing” is displayed on the DOS screen.
- The E4991A logo screen is not displayed after “Searching for Boot Record from IDE-0 .. OK” is displayed.

Troubleshooting

Booting Process Troubleshooting (for serial prefix JP1KH, JP2KH, and MY432)

- Windows always boots with Safe Mode.

NOTE

To use the E4991A functions are necessary to install its device drivers to the operating system. The Agilent factory installs the necessary device drivers to the E4991A (operating system) and ship it. The operating system checks the necessary device drivers. When the operating system doesn't detect them, the message box is displayed. You need to prepare the device driver and to install it, if you experience the above situation.

Figure 4-12

E: E4991A Logo Screen



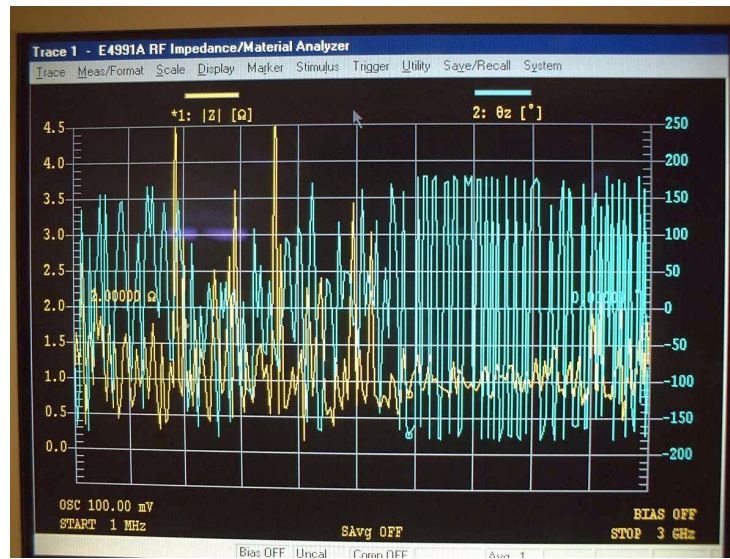
During the logo screen is displayed, an operating system (Windows 98) is loaded from A27 to DIMM64MB.

Step 6. Measurement View

The measurement View as shown in Figure 4-13 is displayed after the E4991A firmware is loaded without problem.

Figure 4-13

G: Measurement View



Step 7. Power On Self Test

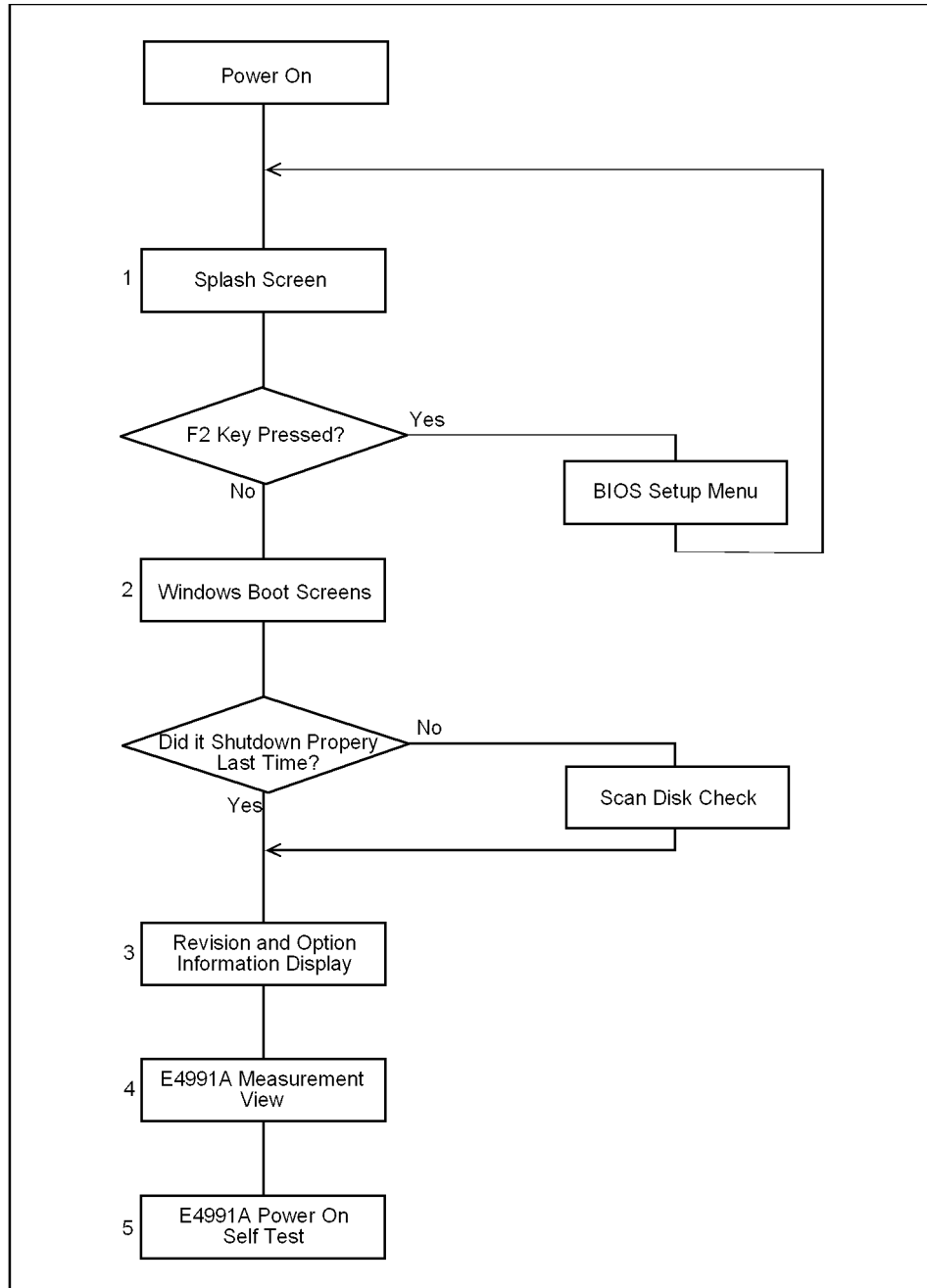
The power on self test is executed once automatically before the measurement starts. For details, refer to “Troubleshooting Using Internal Test” on page 170. In addition, a message of the “Internal Test In Progress...” is displayed during the power on self test in progress. If an hang-up occurs during the power on self test, problem seems in analog block such as A1 Reference OSC, A3 Source, A4 Receiver or A2 DC Bias(Opt.001).

Booting Process Troubleshooting (for serial prefix MY433 and later)

Figure 4-14 represents the booting process flow in the E4991A. If the E4991A stops in the booting process, troubleshoot using the following step-by-step procedure.

Figure 4-14

Booting process flowchart



e4991ase090

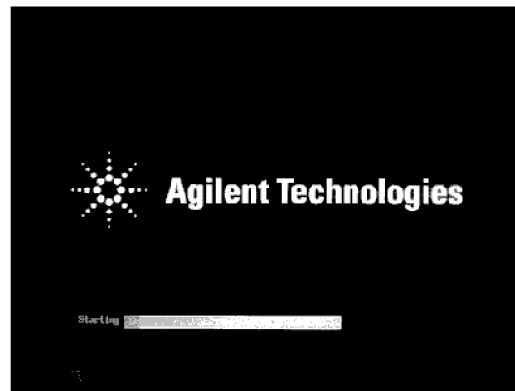
Step 1. Splash Screen

The splash screen is displayed with Agilent logo as shown in Figure 4-15.

If the splash screen is displayed, you can assume that the A20 digital motherboard is functioning correctly.

NOTE

While the splash screen is displayed, if you want to run the BIOS setup utility, push F2 key as soon as in the screen.

Figure 4-15**Splash Screen**

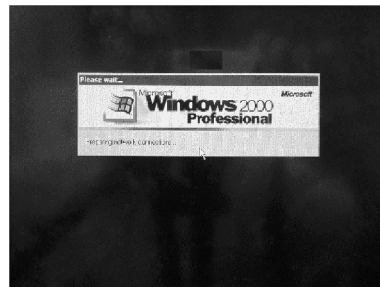
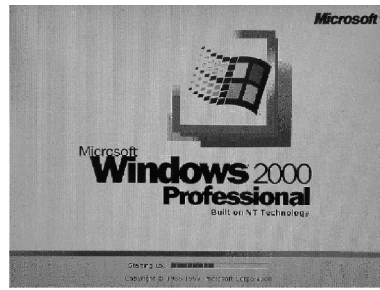
e5061ase049

Step 2. Windows boot screens

The Windows boot screens are displayed. The Windows boot screens consists of two screens. Each screen is displayed in the order as shown in Figure 4-15. If the Windows boot screens are displayed, it is assumed that the A27 HDD works. While the Window screens are displayed, Windows operating system is starting up.

Figure 4-16

Windows boot screens



e5061ase051

If you encounter the following problems, try to reinstall the operating system before replacing the A27.

- "xxx file is missing" is displayed on DOS screen.
- The Window boot screen is not displayed after the splash screen is displayed.
- Windows always boots up with Safe Mode.

NOTE

If the E4991A was turned off without shutdown process, Microsoft Scandisk runs while the windows boot screens are displayed. If a serious problem is found in the scandisk, reinstall the operating system. For details of the operating system installation, refer to Appendix B, "System Installation for A27 Mass Storage," on page 311. If the operating system still doesn't boot up properly after reinstallation, replace the A27.

NOTE

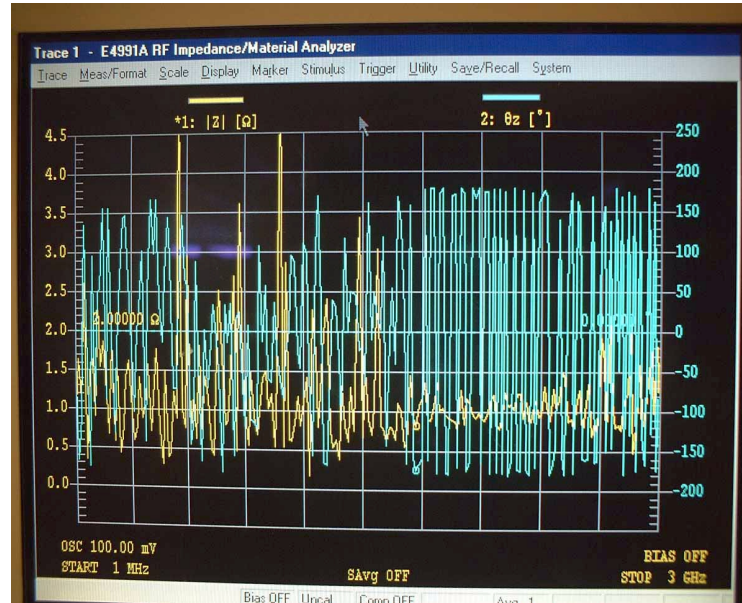
The operating system automatically checks the device drivers, which are necessary to use the E4991A functions and are installed in the system before the E4991A is shipped from Agilent factory. If the operating system doesn't detect them, a message box is displayed. In this case, install the device driver.

Step 3. Measurement view

The measurement view as shown in Figure 4-17 is displayed after the system initialization is completed without problem.

Figure 4-17

Measurement view

**Step 4. Power On Self Test**

The power on self test is executed once automatically before the measurement starts. For details, refer to “Troubleshooting Using Internal Test” on page 170. In addition, a message of the “Internal Test In Progress...” is displayed during the power on self test in progress. If an hang-up occurs during the power on self test, problem seems in analog block such as A1 Reference OSC, A3 Source, A4 Receiver or A2 DC Bias(Opt.001).

Troubleshooting Using Internal Test

Power On Self Test

The E4991A performs the power on self test once after the E4991A is turned on. When the failure part is detected in the E4991A, a message of the “Power on test failed” is displayed. The content of the power on self test is same as the internal test.








PLL unlock

When phase lock loop doesn't work in the E4991A, not “Power on test failed” but “PLL unlock” is displayed.

- If you use the external reference signal (Opt.1D5), check to see if it is correct. If you use the correct signal or you don't use it, there is a possibility to need repair and/or adjustment.
- When the E4991A is turned on from cold, “PLL unlock” is displayed during few time very occasionally because warm-up time is not enough. If “PLL unlock” is displayed continuously after warm-up, there is a possibility to need repair and/or adjustment. There is a possibility that A1 Reference OSC or A3 Source or A5 10MHz Oven(Opt.1D5) gives problem.

To Execute the Internal Test

If the “Power on test failed” is displayed after the E4991A is turned on, you should perform the internal test to isolate the faulty assembly. You can execute the internal test by the following procedure.

- Step 1.** Press **[Menu]** on the front panel.
- Step 2.** Select System Menu using  key.
- Step 3.** Select **Diagnostic** using  key and press  key.
- Step 4.** Select **Internal Test** using  key and press  key.
- Step 5.** Select **Test Start** using  key and press  key in the internal test menu.

Internal Test

The internal test contains the following two tests.

- Analog Test
This is the test to check the function related to the analog section. When the analog test fails, “Analog Test: FAIL” will be displayed.
- System Test
This is the test to check the function related to the digital section. When the system test fails, “System Test: FAIL” will be displayed.

Analog Test Failure Troubleshooting in the Internal Test

When “Analog Test: Fail” is displayed in the internal test, replace the faulty assembly as shown in Table 4-1. The contents of the analog test is as follows;

Table 4-1 Troubleshooting Information for Analog Test Failure

Test No.	First Failed Test	Test Point	Probable Faulty Assembly					
			A1 Ref OSC	A3 Source	A4 Receiver	A2 DC Bias(001)	A5 Freq Ref(1D5)	A6 Test Head
1	DC_A1_P9V	+9V on A1	†††					
2	DC_A1_N9V	-9V on A1	†††					
3	DC_A1_P5VRF1	+5V for RF1 on A1	†††					
4	DC_A1_P5VRF2	+5V for RF2 on A1	†††					
5	DC_A1_P5V	+5V on A1	†††					
6	DC_A3_P5VPLL	+5V for PLL on A3		†††				
7	DC_A3_P10V	-10V on A3		†††				
8	DC_A3_N5V	-5V on A3		†††				
9	DC_A3_N10VPLL	-10V on A3		†††				
10	DC_A3_OUTDET	Detect Level of RFOUT AGC on A3		†††				
11	DC_A3_LODET	Detect Level of Local AGC on A3		†††				
12	DC_A4_P10V	+10.5V on A4			†††			
13	DC_A4_P5V	+5V on A4			†††			
14	DC_A4_P8VA	+8V for CH1 on A4			†††			
15	DC_A4_P8VB	+8V for CH2 on A4			†††			
16	DC_A4_N10_5V	-10.5V on A4			†††			
17	DC_A4_N5V	-5V on A4			†††			
18	DC_A4_LODET	Detect Level of Local AGC on A4		††	†††			
19	A2_STAT	Status of A2				†††		
20	DC_A2_P50V	+50V on A2				†††		
21	DC_A2_N50V	-50V on A2				†††		
22	DC_A2_P5VREF	+5V for Reference on A2				†††		
23	FREQ_A1_VCO1	VCO Output for RF1 on A1	†††					
24	FREQ_A1_REF1	PLL Reference for RF1 on A1	†††					
25	FREQ_A1_VCO2	VCO Output for RF2 on A1	†††					
26	FREQ_A1_REF2	PLL Reference for RF2 on A1	†††					

Table 4-1 Troubleshooting Information for Analog Test Failure

Test No.	First Failed Test	Test Point	Probable Faulty Assembly					
			A1 Ref OSC	A3 Source	A4 Receiver	A2 DC Bias(001)	A5 Freq Ref(1D5)	A6 Test Head
27	FREQ_A3_VCO	VCO Output for A3	††	†††				

†††: Most suspicious assembly

††: Suspicious assembly

NOTE

When many tests fails in Table 4-1, replace A21 Analog Interface Board or A10 Analog Mother Board.

System Test Failure Troubleshooting in the Internal Test

When “System Test: Fail” is displayed in the internal test, check each error using the following procedure.

- ANALOG IF TEST
 1. Turn off the instrument, and then turn on it.
 2. If this fail still remains, replace A21 Analog Interface Board.
- EEPROM TEST
 1. Turn off the instrument, and then turn on it.
 2. If this fail still remains, perform “EEPROM Initialize” and all adjustments using the Adjustment Program as shown in Chapter 3, “Adjustment,”.
 3. If this fail still remains, replace EEPROM, and then perform “Write ID”, “EEPROM Initialize” and all adjustments using the Adjustment Program as shown in Chapter 3, “Adjustment,” and Chapter 8, “Post-Repair Procedures,”.
 4. If this fail still remains, replace A27 HDD, and then perform all adjustments using Adjustment Program as shown in Chapter 3, “Adjustment,” and Chapter 8, “Post-Repair Procedures,”.
- KEYBD TEST
 1. Check the status of each front key and turn off the instrument, and then turn on it.
 2. If this fail still remains, replace A22 Front Keyboard.

NOTE

When “KEYBD TEST” is failed, perform the internal test using the mouse.

- SYSTEM COLOR TEST
 1. Turn off the instrument, and then turn on it.
 2. Usually, this fail is disappeared after rebooting

Function Depend Troubleshooting

Functions

The E4991A has the following typical functions.

- The hardkeys and knob located on the front panel are divided 4 blocks labeled “Entry/Navigation block”, “Measurement block”, “Stimulus block”, and “System block” respectively. Some of the front panel keys control the E4991A functions directly. Refer to “To check the Front Panel” on page 177, if you want to check the front panel.
- Almost all the information required for the measurement value, setup state, result data processing, menu bar, softkey label and others is indicated on the color LCD display. An 8.4-inch TFT display is used. Refer to “To check the LCD” on page 177, if you want to check the LCD.
- Use of the external keyboard ensures effective entry of the numerical value and character string which is connected to the E4991A rear panel. Refer to “To check the External Keyboard” on page 177, if you want to check the external keyboard.
- Use of the mouse allow you to freely move the pointer on the E4991A LCD display, and effective perform a great variety setups which is connected to the E4991A rear panel. Refer to “To check the Mouse” on page 178, if you want to check the mouse.
- The floppy disk drive is used to save the E4991A setup state and measurement data in the floppy disk and to call them up. It is compatible with a 3.5-inch, 720KB or 1.44MB, DOS format floppy disk. Refer to “To check the FDD” on page 178, if you want to check the FDD.
- The external color monitor is available to display the same information as the E4991A LCD. Refer to “To check the VGA Display Output” on page 178, if you want to check the VGA Display Output.
- The external trigger input terminal allows you to enter the trigger signal to command execution of measurement. Refer to “To check the External Keyboard” on page 177, if you want to check the external trigger input.
- You can use the LAN port to connect the E4991A to the LAN. Refer to “To check the LAN (for serial prefix JP1KH, JP2KH, and MY432)” on page 179, if you want to check the LAN.
- A specified printer is available to print out the E4991A measurement display, setup display and others. You can use it to connect the printer parallel port. Refer to “To check the Printer Parallel port (for serial prefix JP1KH, JP2KH, and MY432)” on page 186, if you want to check the printer parallel port.
- It is available to build an automatic measurement by connecting the external controller and other equipment through GPIB connector. Refer to “To check the GPIB” on page 186, if you want to check the GPIB.

To check the Device Driver (for serial prefix JP1KH, JP2KH, and MY432)

Make sure first whether the E4991A device drivers are installed properly or not by the following procedure, if you experience the E4991A function doesn't work.

- Step 1.** Exit from the E4991A Measurement Display as shown in “How to exit from the E4991A Measurement View” on page 153. Then windows desktop screen is displayed.
- Step 2.** Right mouse click “My Computer” icon, and click “Properties”. Then System Properties dialog box is displayed.
- Step 3.** Click **Device Manager** tag. The operating system detects all the necessary device driver, Figure 4-18 is displayed. However, if it doesn't detect the necessary device driver, a yellow back grounded “!” icon as shown in Figure 4-19 is displayed. The Figure 4-19 shows the example of the operating system doesn't detect the LAN board (3Com EtherLink 10/100 PCI TX NIC [3C905B-TX]) properly. So, the device of the LAN board with the yellow back grounded “!” icon is displayed.

Figure 4-18

View Installed Device Drivers

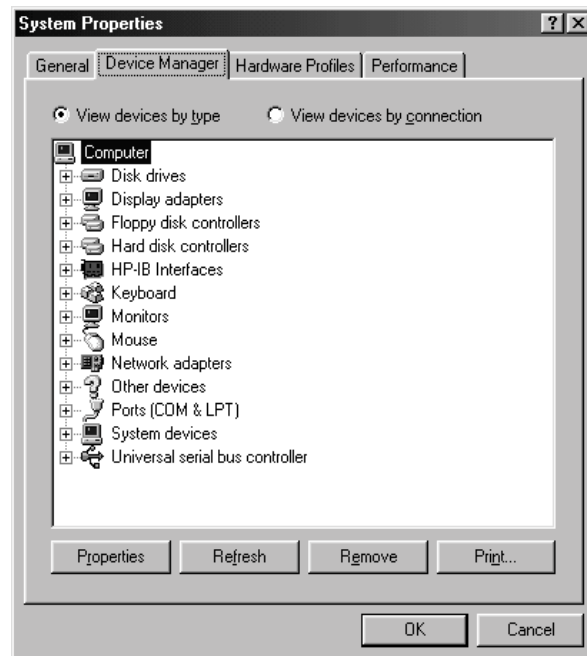
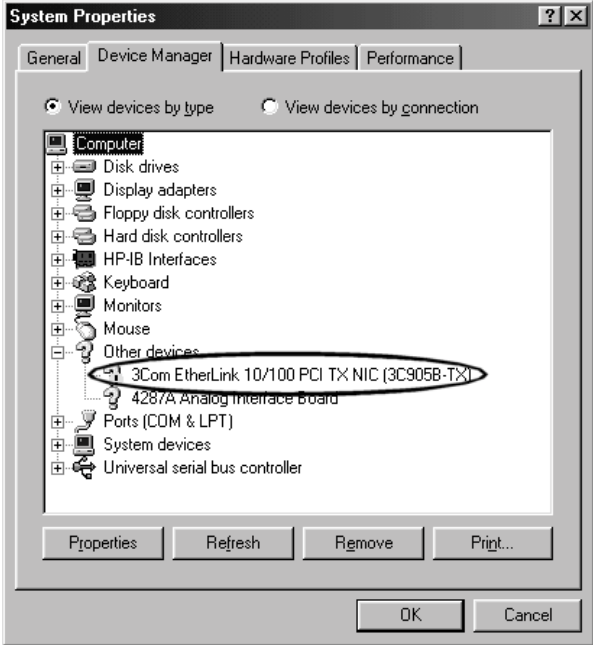


Figure 4-19 Example of no device driver file in system



To check the Device Driver (for serial prefix MY433 and later)

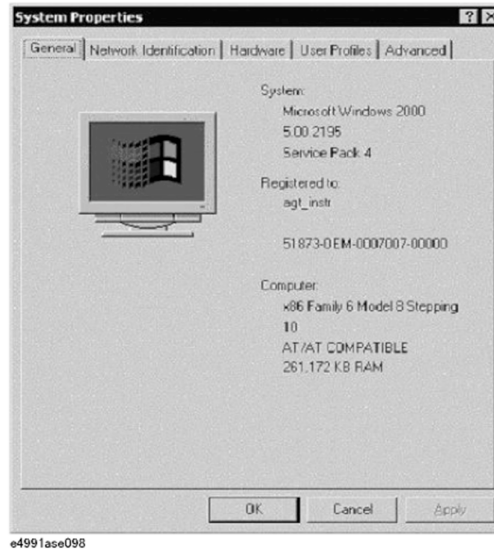
Make sure first whether the E4991A device drivers are installed properly or not by the following procedure, if you experience the E4991A function doesn't work.

- Step 1.** Exit from the E4991A Measurement Display as shown in "How to exit from the E4991A Measurement View" on page 153. Then windows desktop screen is displayed.
- Step 2.** Click "My Computer" with the right button and select "Properties" as shown in Figure 4-20. Then, the System Properties(Figure 4-21) will appear.

Figure 4-20 Opening System Property Window

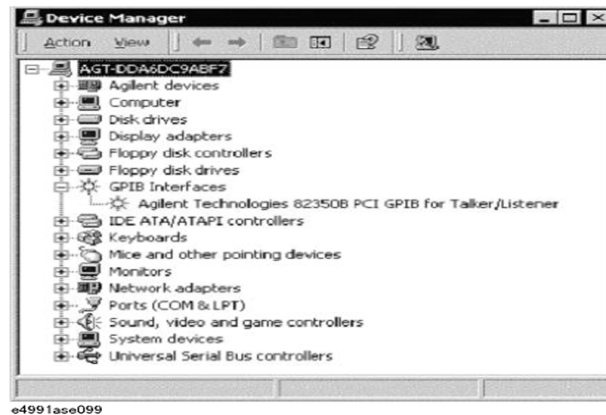


Figure 4-21 System Properties Window (General)



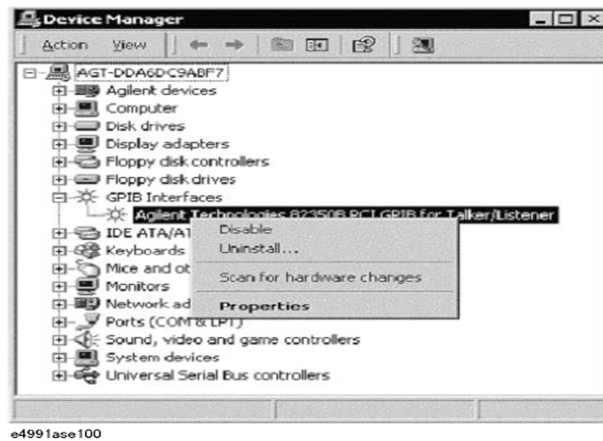
Step 3. Click Hardware tab and Device Manager button. The operating system detects all the necessary device drivers and displays the device names as shown in Figure 4-22.

Figure 4-22 System Properties Window (Hardware)



Click the icon with the right button and click Property to show the detail of the status, as shown in Figure 4-23.

Figure 4-23 Opening Device Driver Property



To check the Front Panel

Procedure

Randomly press the front panel keys and rotate the knob to verify that they work correctly.

You can check this function using the external test as showing in “To Execute the Internal Test” on page 170

If any fail to work, it assumes that the A22 Front keyboard or A21 Analog Interface board gives problem. Or, it assume that any front panel key has been subsided in the panel.

To check the LCD

You can check this function using the external test as showing in “To Execute the Internal Test” on page 170

To check the External Keyboard

Procedure

- Step 1.** Connect the external keyboard to the E4991A rear.
- Step 2.** Turn the E4991A on.
- Step 3.** Press [Menu] key.
- Step 4.** Press the [↑], [↓] keys on the external keyboard, and make sure that the cursor on the menu bar moves to up or down. If any fail to work, there is a possibility that the external keyboard or the A20 Digital Motherboard gives problem.

To check the Mouse

Procedure

- Step 1.** Connect the mouse to the E4991A rear.
- Step 2.** Turn the E4991A on.
- Step 3.** Move the mouse and press the mouse buttons, and make sure that the mouse pointer moves smoothly and the mouse buttons work correctly. If any fail to work, there is a possibility that the mouse or the A20 Digital Motherboard gives problem.

To check the FDD

Procedure

- Step 1.** Inset the floppy disk into the E4991A FDD.
- Step 2.** Click the followings. Then “Save As” dialog box is displayed.

Save/Recall - SAVE STATE

- Step 3.** Select the drive and file name as follows;

Drive: [-a-]

File name: e4991a

Then, click **OK**. If any fail to work, there is a possibility that the floppy disk, the A28 FDD or the flat cables between the FDD and the A20 Digital Motherboard via the A26 Display board gives problem.

- Step 4.** Next, click the followings to recall the state file you saved. Then “Open” dialog box is displayed.

Save/Recall - RECALL STATE

- Step 5.** Select the drive and file name as follows;

Drive: [-a-]

File name: e4991a

Then, click **OK**. If any fail to work, there is a possibility that the floppy disk, the A28 FDD or cable between the FDD and the A20 Digital Motherboard gives problem.

To check the VGA Display Output

Procedure

- Step 1.** Connect the external monitor to the E4991A rear.
- Step 2.** Turn the external monitor on.
- Step 3.** Make sure that the screen on the external monitor is the same as the screen on the LCD. If screen is not displayed on the external monitor, there is a possibility that the A26 Display board gives problem.

To check the External Trigger Input

Procedure

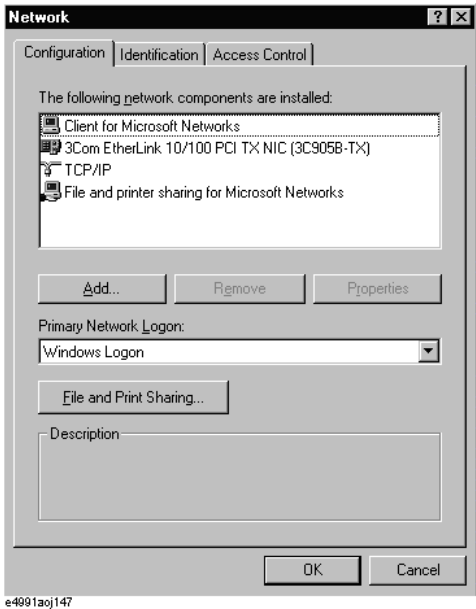
- Step 1.** Press [**Preset**] key. Then the E4991A is initialized.
- Step 2.** Select the trigger source to “EXTERNAL” by following front panel procedure.
[Trigger Setup] - Trigger Source - External
- Step 3.** Attach the 50ohm termination(BNC) to the E4991A Ext Trig connector rear, then a trigger is generated and measurement data is displayed.
- Step 4.** Remove the 50ohm termination(BNC) from the E4991A Ext Trig connector rear, then a trigger is generated and measurement data is displayed.
- Step 5.** If measurement doesn't execute under the external trigger in spite of the internal trigger works properly, there is a possibility that the A21 Analog Interface board gives problem.

To check the LAN (for serial prefix JP1KH, JP2KH, and MY432)

Procedure

- Step 1.** Connect the LAN cable between the E4991A rear and the personal computer. If you have a crossed LAN cable, it is available to connect with them directly. Or, if have a straight LAN cable, it is available to connect with them via multi port Hub.
- Step 2.** Exit from the E4991A Measurement Display as shown in “How to exit from the E4991A Measurement View” on page 153. Then windows desktop screen is displayed.
- Step 3. Set up the IP address/subnet mask**
 - a.** Open the shortcut menu by right-clicking the **Network Neighborhood** icon on the desktop and click **Properties**. This opens up the **Network** dialog box (Figure 4-24).

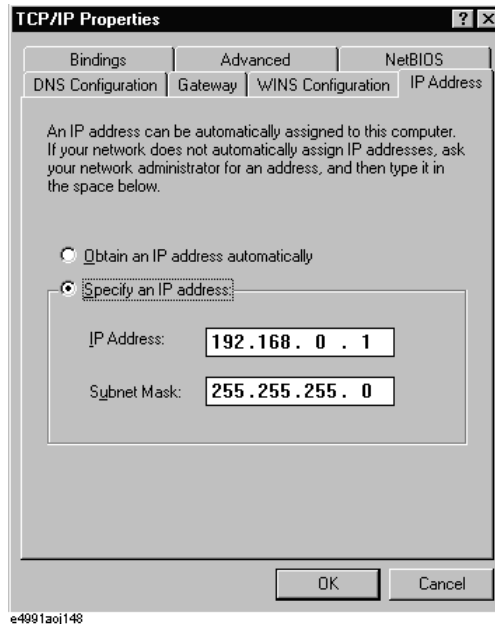
Figure 4-24 Network dialog box



Troubleshooting
Function Depend Troubleshooting

- b. Click the **TCP/IP** icon in the **Configuration** tab to select it.
- c. Click the **Properties** button. This opens the **TCP/IP Properties** dialog box (Figure 4-25).

Figure 4-25 TCP/IP Properties dialog box (IP Address tab)



- d. If the IP Address and the Subnet Mask are not assigned yet, enter them as follows.

IP Address 192.168.0.1
Subnet Mask 255.255.255.0

If they are already assigned, go to step 4.

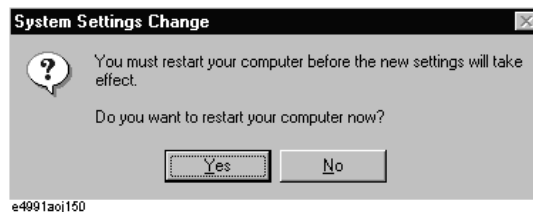
The following is how to enter the IP Address and the Subnet Mask.

Click the **Specify an IP address** option button in the **IP Address** tab to select it and input your IP address in the **IP Address** box and your subnet mask in the **Subnet Mask** box (overwrite the initial values) to assign a specific IP address and subnet mask.

Step 4. Shut down the E4991A

- a. Click the **OK** button to close the **TCP/IP Properties** dialog box.
- b. Click the **OK** button to close **Network** dialog box. This opens the **System Setup Change** dialog box (Figure 4-26).

Figure 4-26 System Setup Change dialog box



- c. Click the **Yes** button to restart the E4991A.

NOTE

Shut down the E4991A by following the procedure below if you click the **No** button by mistake.

1. Click **Start - Shut Down...**
 2. Click the **Shut down** button in the **Shut Down Windows** dialog box to select it.
 3. Click the **OK** button.
-

Step 5. Turn the E4991A on again, after shutdown. Then, the LAN settings take effect.

Step 6. Open the DOS prompt by the following the mouse procedure from personal computer.

Start - Programs - MS-DOS Prompt

You can confirm whether the E4991A LAN hardware and setting is available or not using ping command. Type “ping xxx.xxx.xxx.xxx”, and press **[Enter]** key from the Command Prompt window. Where “xxx.xxx.xxx.xxx” is the IP address of the E4991A you assigned.

Figure 4-27 and Figure 4-28 are examples of the ping command response. When the E4991A returns response to the personal computer, such a Figure 4-27 is displayed. When the E4991A doesn't return the response, such a Figure 4-28 is displayed.

If the E4991A doesn't return the response, there is a possibility that the A25 LAN Interface board gives problem.

Figure 4-27

Example of the ping command succeeds

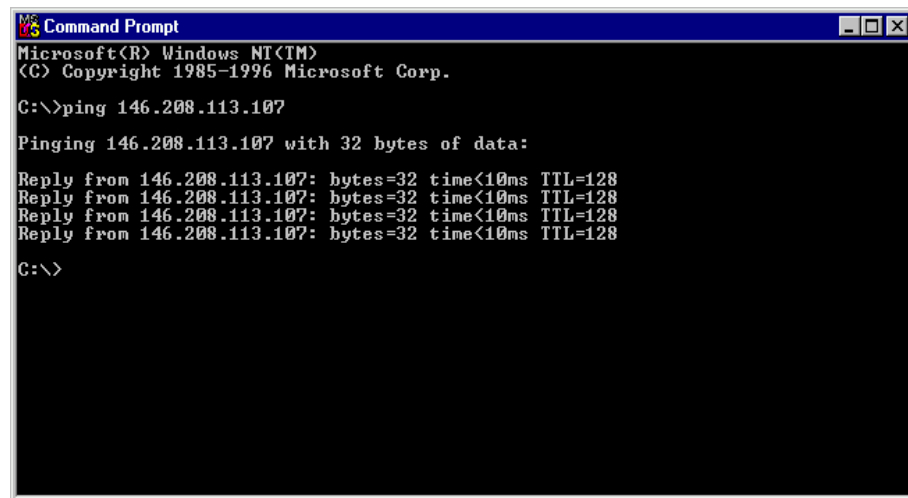
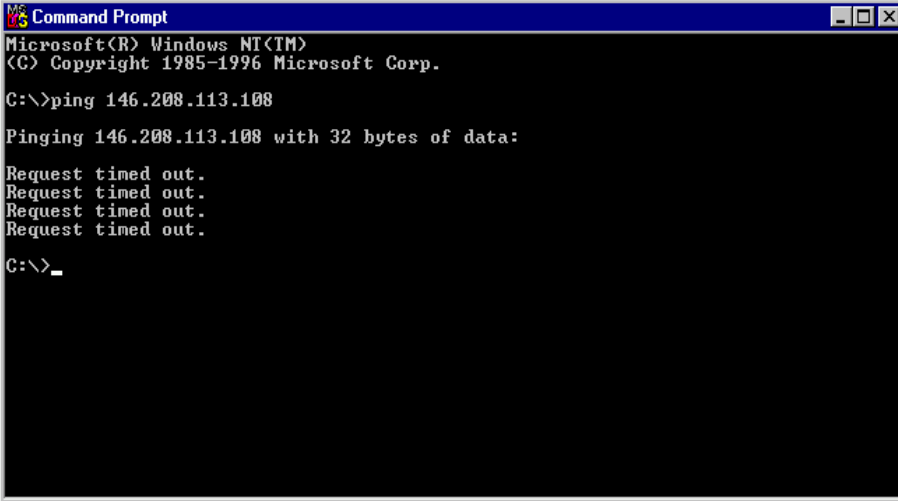


Figure 4-28

Example of the ping command fails



```
Microsoft Windows [Version 5.00.2600.5512]
Copyright (c) 2006 Microsoft Corporation. All rights reserved.

C:\>ping 146.208.113.108

Pinging 146.208.113.108 with 32 bytes of data:

Request timed out.
Request timed out.
Request timed out.
Request timed out.

C:\>_
```

To Check the LAN (for serial prefix MY433 and later)

Procedure

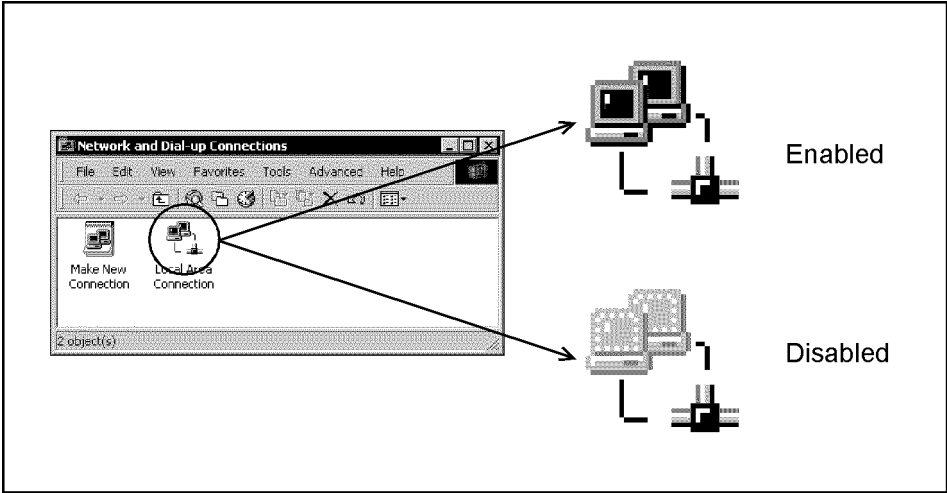
- Step 1.** Exit from the E4991A Measurement Display as shown in “How to exit from the E4991A Measurement View” on page 153. Then windows desktop screen is displayed.
- Step 2.** Connect a LAN cable between the LAN port on the rear panel and an external computer (PC).

NOTE

Use a crossed LAN cable to enable the peer-to-peer communication between the E4991A and the PC. If the E4991A needs to be connected to the PC via a multi port Hub, use a straight LAN cable.

- Step 3.** Double-click “**My Computer**” icon on Windows desktop of the E4991A. And double-click “**Control Panel**”. The Control Panel window will appear.
- Step 4.** Double-click “**Network and Dial-up Connections**” icon to show the Network and Dial-up Connections window as shown in the left of Figure 4-29.

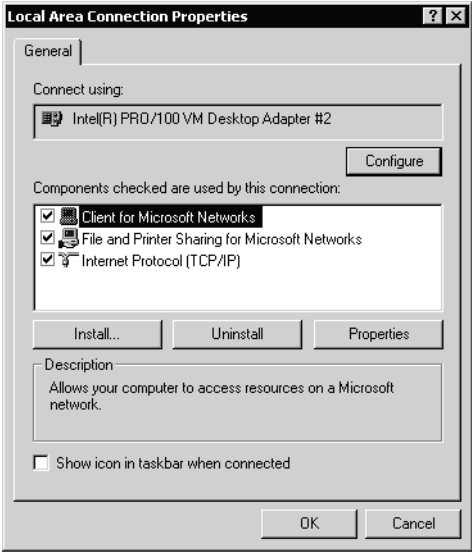
Figure 4-29 Network and Dial-up Connections window



e5070bse117

- Step 5.** Check the Local Area Connection icon to confirm whether the network connection is enabled or disabled. The meaning of the icon is shown in the right of Figure 4-29. If the connection is disabled, Double-click the Local Area Connection icon.
- Step 6.** Set up the IP address/subnet mask as follows.
 - a. Click the Local Area Connection icon with the right button and click "Properties". This opens the "Local Area Connection Properties" dialog box as shown in Figure 4-30.

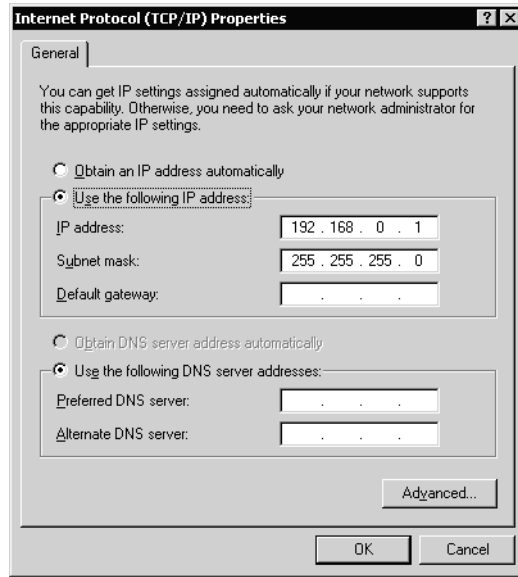
Figure 4-30 Network dialog box



e5070bse115

- b. Click "Internal Protocol (TCP/IP)" icon.
- c. Click the "Properties" button. This opens the "TCP/IP Properties" dialog box as shown in Figure 4-31.

Figure 4-31 TCP/IP Properties dialog box (IP Address tab)



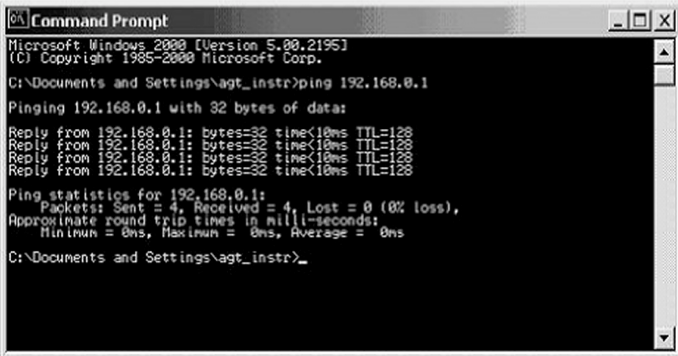
- d. If the IP Address and the Subnet Mask are already assigned, go to Step 7. If they are not assigned yet, enter them as follows:

IP Address 192.168.0.1
Subnet Mask 255.255.255.0
Default Gateway blank

To enter a specific IP Address and Subnet Mask, click "Use the following IP address" option button to select it. Input your IP address in the "IP Address" box and your subnet mask in the Subnet Mask box (overwrite the initial values).

- Step 7.** By clicking "OK" button, the network settings take effect. Verify the E4991A LAN settings and response to a command from the external computer as follows:
- On the external computer, click "Start" button in the Windows Start menu bar using a mouse.
 - Click "Programs" and "Accessories" and "Command Prompt" to open the DOS (Command) Prompt window.
 - Type a ping command followed by the E4991A IP address as "ping xxx.xxx.xxx.xxx" (where, xxx.xxx.xxx.xxx is the IP address such as 192.168.0.1 assigned in Step 6-d.) Press key on the keyboard.
 - The external computer displays a message of ping command response from the E4991A. Figure 4-32 shows an example of normal result that indicates the IP address, packet size, and a response time counted by the computer. The ping command is repeated 4 times.

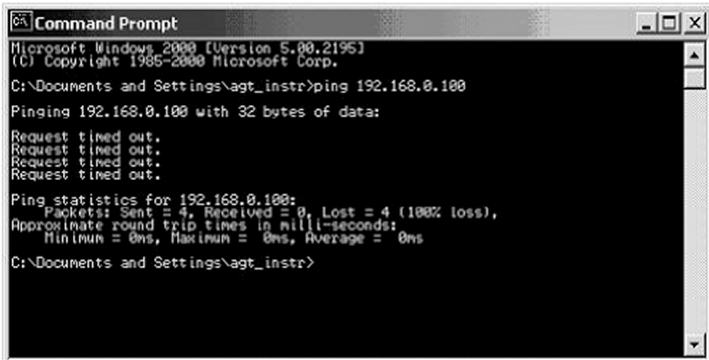
Figure 4-32 Example of normal ping command test result



e4991ase101

If the E4991A doesn't return the response, the external computer displays a message of "Request timed out" as shown in Figure 4-33. In this case, a failure in the A20 digital motherboard is suspected.

Figure 4-33 Example of no response for ping command



e4991ase102

To check the Printer Parallel port (for serial prefix JP1KH, JP2KH, and MY432)

Test Equipment

Please refer

http://www.agilent.com/find/ctdkobe_printers

for the latest supported printers.

Printer Cable (Parallel Cable)

Procedure

- Step 1.** Connect the printer cable between the printer and the E4991A printer parallel port.
- Step 2.** Press **[Preset]** key. Then the E4991A is initialized.
- Step 3.** Start printing by following mouse procedure. Then Press **OK** on Print Menu.

Display - PRINT - Graph[Mono]

- Step 4.** If any fail to work, there is a possibility that the A20 Digital Mother board, connection of the printer cable or the printer driver gives problem.

To check the Printer USB port (for serial prefix MY433 and later)

Test Equipment

Please refer

http://www.agilent.com/find/ctdkobe_printers

for the latest supported printers.

Printer Cable (USB Cable)

Procedure

- Step 1.** Connect the printer cable between the printer and the E4991A USB port.
- Step 2.** Press **[Preset]** key. Then the E4991A is initialized.
- Step 3.** Start printing by following mouse procedure. Then Press **OK** on Print Menu.

Display - PRINT - Graph[Mono]

- Step 4.** If any fail to work, there is a possibility that the A20 Digital Mother board, connection of the printer cable or the printer driver gives problem.

To check the GPIB

Procedure

Perform the E4991A performance test program. If the controller can not detect the E4991A, there is a possibility that the A24 GPIB board or connection of the GPIB cable gives problem.

External Tests Failure Troubleshooting

If you can't identify the faulty assembly using the internal tests, you can execute the external tests in addition to the internal tests. These external tests are also built-in tests and 9 tests are available in the E4991A diagnostic test mode. Refer to Table 4-2 to know which assembly is probably faulty and should be replaced.

To Execute the External Test

To execute the external tests, perform the following procedures. This procedure should be done with the mouse and the external keyboard.

- Step 1.** Connect the mouse and the external keyboard to rear panel, and then turn on E4991A.
- Step 2.** Click System Menu on the menu bar.
- Step 3.** Click **Diagnostic** in the System menu.
- Step 4.** Double-Click **External Test** in the Diagnostic menu. Then the External Test dialog box is opened.
- Step 5.** Click the button of the each test to execute the specified test.
- Step 6.** Perform each test according to the instruction.

The contents of the external test

The external test contains the following tests.

- Front Keyboard & LCD Display
- Source
- Out ATT
- Input ATT
- IF Gain
- Front Isolation
- Test Head
- DC Bias
- Z Meas

Front Keyboard & LCD Display Test

This test is to check if the function of the front keyboard and the LCD works normally.

Required Equipment

Nothing

Procedure

The following is the procedure to perform the Front Keyboard & LCD Display Test

- Step 1.** Open the External Test dialog box as described in “To Execute the External Test” on page 187.
- Step 2.** Click **1.Front Keyboard & LCD Display** on External Test dialog box.
- Step 3.** Push the front key according to the front keyboard map, and confirm if the key and the knob work normally.
- Step 4.** Click each LCD button on LCD Display Menu, and confirm if the function of the LCD works normally.
- Step 5.** Click **PASS** and exit this window, if all tests is passed. Click **FAIL** and exit this window, if a test is failed.

Source Test

This test is to check if the function of the receiver reads the level of the source normally.

Required Equipment

Description	Recommended Model
Calibration Kit	16195B (50 ohm)

Procedure

The following is the procedure to perform the Source Test.

- Step 1.** Connect the Test Head to the instrument.
- Step 2.** Open the External Test dialog box as described in “To Execute the External Test” on page 187.
- Step 3.** Click **2.Source** on External Test dialog box.
- Step 4.** Connect the 50ohm Termination of the 16195B to DUT Port on the Test Head. Then click **OK**.
- Step 5.** Click **OK & Next>>** to go to the next test.

Out ATT Test

This test is to check if the Output Attenuator on A3 Board is changed normally.

Required Equipment

Description	Recommended Model
Calibration Kit	16195B (50 ohm)

Procedure

The following is the procedure to perform the Out ATT Test.

- Step 1.** Connect the Test Head to the instrument.
- Step 2.** Open the External Test dialog box as described in “To Execute the External Test” on page 187.
- Step 3.** Click **3.Out ATT** on External Test dialog box.
- Step 4.** Connect the 50ohm Termination of the 16195B to DUT Port on the Test Head. Then click **OK**.
- Step 5.** Click **OK & Next>>** to go to the next test.

Input ATT Test

This test is to check if the Input Attenuator on A4 Board is changed normally.

Required Equipment

Description	Recommended Model
Calibration Kit	16195B (50 ohm)

Procedure

The following is the procedure to perform the Input ATT Test.

- Step 1.** Connect the Test Head to the instrument.
- Step 2.** Open the External Test dialog box as described in “To Execute the External Test” on page 187.
- Step 3.** Click **4.Input ATT** on External Test dialog box.
- Step 4.** Connect the 50ohm Termination of the 16195B to DUT Port on the Test Head. Then click **OK**.
- Step 5.** Click **OK & Next>>** to go to the next test.

IF Gain Test

This test is to check if the IF Gain(IF=12.5kHz, 10kHz) on A4 Board works normally.

Required Equipment

Description	Recommended Model
Calibration Kit	16195B (50 ohm)

Procedure

The following is the procedure to perform the IF Gain Test.

- Step 1.** Connect the Test Head to the instrument.
- Step 2.** Open the External Test dialog box as described in “To Execute the External Test” on page 187.
- Step 3.** Click **5.IF Gain** on External Test dialog box.
- Step 4.** Connect the 50ohm Termination of the 16195B to DUT Port on the Test Head. Then click **OK**.

Front Isolation Test

This test is to isolate PORT1 and PORT2 on A4 Board.

Required Equipment

Description	Recommended Model
50 ohm Termination(N)	HP 909C Opt.012
N(m)-N(m), 61cm Cable	11500B

Procedure

The following is the procedure to perform the Front Isolation Test.

- Step 1.** Make sure that nothing is connected to the instrument.
- Step 2.** Open the External Test dialog box as described in “To Execute the External Test” on page 187.
- Step 3.** Click **6.Front Isolation** on External Test dialog box.
- Step 4.** Connect RF OUT and PORT2 using N Cable, and connect the 50ohm Termination(N) to PORT1. Then click **OK**.
- Step 5.** Click **OK & Next>>** to go to the next test.
- Step 6.** Connect RF OUT and PORT1 using N Cable, and connect the 50ohm Termination(N) to PORT2. Then click **OK**.
- Step 7.** Click **OK & Next>>** to go to the next test.

Test Head Test

This test is to check if the test head works normally.

Required Equipment

Description	Recommended Model
Calibration Kit	16195B (50 ohm)
N(m)-N(m), 61cm Cable	11500B

Procedure

The following is the procedure to perform the Test Head Test.

- Step 1.** Make sure that nothing is connected to the instrument.
- Step 2.** Open the External Test dialog box as described in “To Execute the External Test” on page 187.
- Step 3.** Click **7.Test Head** on External Test dialog box.
- Step 4.** Connect RF OUT and PORT1 using N Cable. Then click **OK**.
- Step 5.** Connect RF OUT and PORT2 using N Cable. Then click **OK**.
- Step 6.** Connect the Test Head to the instrument, and connect the 50ohm Termination of the 16195B to DUT Port on the Test Head. Then click **OK**.
- Step 7.** Click **OK & Next>>** to go to the next test.

DC Bias Test (Option 001 only)

This test is to check if the function of A2 DC Bias Board(Option 001) works normally.

Required Equipment

Description	Recommended Model
Calibration Kit	16195B (Open, Short, 50 ohm)

Procedure

The following is the procedure to perform the DC Bias Test.

- Step 1.** Connect the Test Head to the instrument.
- Step 2.** Open the External Test dialog box as described in “To Execute the External Test” on page 187.
- Step 3.** Click **8.DC Bias** on External Test dialog box.
- Step 4.** Connect the OPEN(0 S) Termination of the 16195B to DUT Port on the Test Head. Then click **OK**.

Step 5. Connect the SHORT(0 ohm) Termination of the 16195B to DUT Port on the Test Head. Then click **OK**.

Step 6. Connect the 50 ohm Termination of the 16195B to DUT Port on the Test Head. Then click **OK**.

Z Meas Test

This test is to check if the measurement of OPEN, SHORT and LOAD works normally.

Required Equipment

Description	Recommended Model
Calibration Kit	16195B (Open, Short, 50 ohm)

Procedure

The following is the procedure to perform the Z Meas Test.

Step 1. Connect the Test Head to the instrument.

Step 2. Open the External Test dialog box as described in “To Execute the External Test” on page 187.

Step 3. Click **9.Z meas** on External Test dialog box.

Step 4. Connect the OPEN(0 S) Termination of the 16195B to DUT Port on the Test Head. Then click **OK**.

Step 5. Click **OK & Next>>** to go to the next test.

Step 6. Connect the SHORT(0 ohm) Termination of the 16195B to DUT Port on the Test Head. Then click **OK**.

Step 7. Click **OK & Next>>** to go to the next test.

Step 8. Connect the 50 ohm Termination of the 16195B to DUT Port on the Test Head. Then click **OK**.

Step 9. Click **OK & Next>>** to go to the next test.

External Test Failure Troubleshooting

When the external test fails, replace the faulty assembly as shown in Table 4-2.

Table 4-2 Troubleshooting Information for External Test Failure

Test No.	First Failed Test	Probable Faulty Assembly					
		A1 Ref OSC	A3 Source	A4 Reciever	A2 DC Bias(001)	A5 Freq Ref(1D5)	A6 Test Head
1	FRONT KEY & LCD*1						
2	SOURCE	††	†††	††			
3	OUTPUT ATT	††	†††	††			
4	INPUT ATT	††	††	†††			
5	IF GAIN	††	††	†††			
6	FRONT ISOLATION			†††			
7	TEST HEAD						†††
8	DC BIAS TEST				†††		
9	Z MEAS	††	†††	†††	††	†	††

*1.If “FRONT KEY &LCD” test fails, verify A22 Front Panel Keyboard, A51 LCD, A21 Analog Interface Board and A26 Display Board.

†††: Most suspicious assembly

††: Suspicious assembly

†: There is some possibility of a fault

Performance Tests Failure Troubleshooting

Perform the following procedure sequentially when any performance tests fail.

Troubleshooting for Performance Test Failure

Table 4-3 gives the recommended adjustments when the performance test fails. You should perform the corresponding adjustments using the Spot Adjustment in the Adjustment Program as shown in Table 4-3. If the performance test still fails, replace the assembly as shown in Table 4-4. Note that this table lists some typical cases. In a few cases, other assembly may actually be faulty.

Table 4-3

Recommended Adjustment for Performance Test Failure

Test No.	First Failed Test	Recommended Adjustment (Spot Adjustment in Adjustment Program)				
		A1 Adjustment	A3 Adjustment	A4 Adjustment	A2 Adjustment	A5 Adjustment
1	Frequency Accuracy Test (Std)	√				
	Frequency Accuracy Test (Opt. 1D5)					√
2	OSC Level Accuracy Test		√			
3	Impedance measurement accuracy test		√			
4	DC Bias Level accuracy Test (Opt.001)				√	

Table 4-4

Isolate Faulty Assembly for Performance Test Failure

Test No.	First Failed Test	Probable Faulty Assembly				
		A1 Ref OSC	A3 Source	A4 Receiver	A2 DC Bias(001)	A5 Freq Ref(1D5)
1	Frequency Accuracy Test (Std)	†††				
	Frequency Accuracy Test (Opt. 1D5)					†††
2	OSC Level Accuracy Test		†††			
3	Impedance Measurement Accuracy Test		††	†††		
4	DC Bias Level Accuracy Test (Opt. 001)				†††	

†††: Most suspicious assembly

††: Suspicious assembly

To Configure the A20 Digital Motherboard and BIOS (for serial prefix JP1KH, JP2KH, and MY432)

If you replace the A20 Digital Motherboard, you need to confirm the jumpers for the specific CPU installed. You also need to confirm the BIOS options using the BIOS setup utility procedure. And, the BIOS detects the A27 Mass Storage connected to the A20, and displays these parameters. It is a useful tool to verify whether the A27 gives problem or not.

The jumpers on the A20 and the BIOS setups are presented in the following pages.

To Identify the Motherboard Used

The E4991A consists of Digital Motherboard and AMD-K6/2-400MHz processor. This motherboard displays the message "Hunter ATX - PE-PHATX-03 - xx/xx/xx" and "AMD-K6-2-/400" during the Memory checking after power on as shown in Figure 4-8.

Configure the Motherboard

There are several jumpers on the A20 digital motherboard that must be configured to the correct settings for the AMD-K6/2-400MHz microprocessor as shown in Table 4-5 to Table 4-12. Figure 4-34 shows the A20 digital motherboard jumpers location.

Table 4-5

JP1

1-2	2-3
OFF	ON

Table 4-6

JP2

1-2	3-4	5-6	7-8
ON	OFF	OFF	OFF

Table 4-7

JP3 CPU Speed (AMD-K6/2E-400MHz)

1-2	3-4	5-6
ON	OFF	OFF

Table 4-8

JP4 BUS Clock (66MHz)

1-2	3-4	5-6
OFF	OFF	ON

Table 4-9

JP7 BIOS Write Protect (Non Writable)

1-2	2-3
ON	OFF

Table 4-10

JP9 CMOS Reset (Normal)

1-2	2-3
ON	OFF

Table 4-11

JP10 CPU Voltage Selection (2.2V)

1-2	3-4	5-6	7-8
OFF	ON	OFF	OFF

Table 4-12

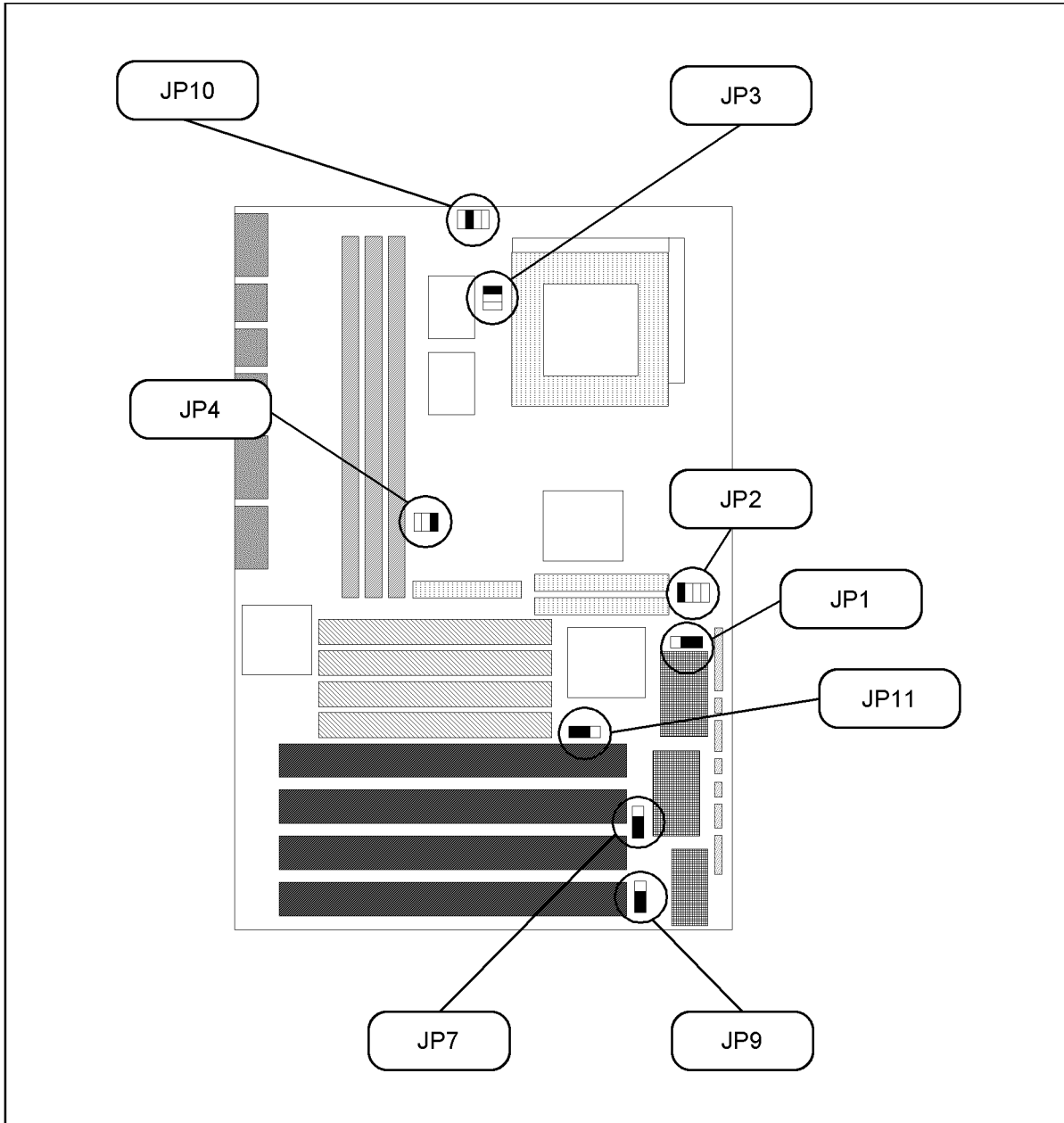
JP11 Power On Select

1-2	2-3
ON	OFF

To Configure the A20 Digital Motherboard and BIOS (for serial prefix JP1KH, JP2KH, and MY432)

NOTE If the jumper settings, especially jumper 3, 4, or 10 is incorrect, there is a possibility that it gives damage to the microprocessor. You must be attentive to configure the jumpers.

Figure 4-34 A20 Digital Motherboard Jumpers Location



e4991ase031

Troubleshooting

To Configure the A20 Digital Motherboard and BIOS (for serial prefix JP1KH, JP2KH, and MY432)

To Confirm or Set the BIOS Options

Generally, BIOS (Basic Input Output System) is a software to control the data input/output of the personal computer. The E4991A has the BIOS inside. Use the following procedure to confirm or set the BIOS options, known as the BIOS setup utility.

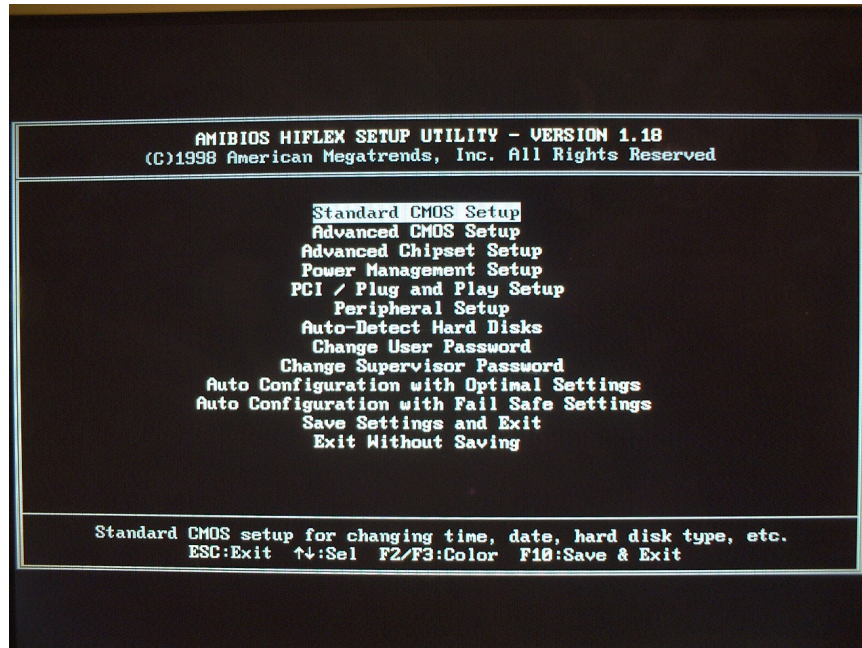
Run the BIOS setup utility

You can use the external keyboard in the BIOS setup utility to perform various functions.

- Step 1.** Connect the external keyboard to the E4991A rear panel. Then turn the E4991A on.
- Step 2.** Hit **[Delete]** key as soon as the message of “Hit DEL if you want to run SETUP” is displayed.
- Step 3.** Enter password as “e4991a” when you are required it. Then Figure 4-35 is displayed.

Figure 4-35

BIOS setup utility main menu Page



The BIOS setup utility has 11 windows. For details of the BIOS options in the each window are described in bellow pages. You can select a window using **[↑]**, **[↓]** keys or **[Tab]** key, and perform an operation using **[Enter]** key.

To Configure the A20 Digital Motherboard and BIOS (for serial prefix JP1KH, JP2KH, and MY432)

The windows are:

- Standard COMS Setup

The default settings of all the Standard CMOS Setup options are described in the “Standard CMOS Setup” on page 200.

- Advanced CMOS Setup

The default settings of all the Advanced CMOS Setup options are described in the “Advanced CMOS Setup” on page 201.

- Advanced Chipset Setting

The default settings of all the Advanced Chipset Setting options are described in the “Advanced Chipset Setup” on page 202.

- Power Management Setup

The default settings of all the Power Management Setup options are described in the “Power Management Setup” on page 203.

- PCI/Plug and Play Setup

The default settings of all the PCI/Plug and Play Setup options are described in the “PCI / Plug and Play Setup” on page 204.

- Peripheral Setup

The default settings of all the Peripheral Setup options are described in the “Peripheral Setup” on page 205.

- Auto-Detect Hard Drive

After replacing the A27 Mass Storage, you can confirm whether the connection between the A27 and the A20 Digital Motherboard is good or not. Because, BIOS automatically configures the drive parameters after A27 has detected.

- Change User Password

This option is unnecessary to use in the E4991A.

- Change Supervisor Password

- Auto Configuration With Optimal Settings

This option is unnecessary to use in the E4991A.

- Auto Configuration With Fail Safe Settings

This option is unnecessary to use in the E4991A.

- Save Settings and Exit

If you want to quit from BIOS setup utility without saving, select a “Exit Without Saving”. For details, refer to “Exit Without Saving” on page 207.

- Exit Without Saving

If you want to quit from BIOS setup utility with saving, select a “Save Setting and Exit”. For details, refer to “Save Settings and Exit” on page 207.

Troubleshooting

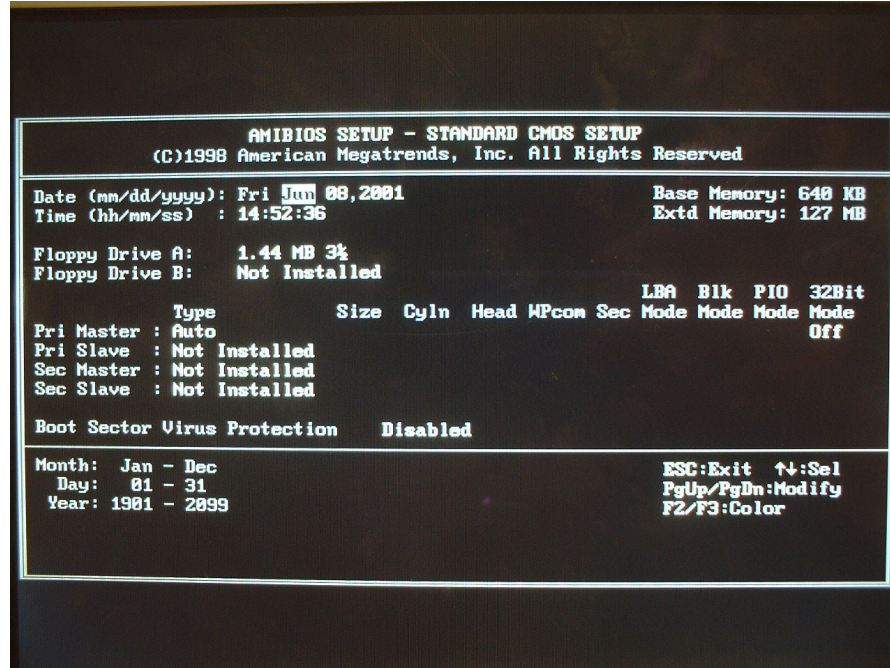
To Configure the A20 Digital Motherboard and BIOS (for serial prefix JP1KH, JP2KH, and MY432)

Standard CMOS Setup

Standard Setup options are displayed by choosing “Standard CMOS Setup” using [↑], [↓] keys and hit [Enter] key at the BIOS setup utility main menu. Then Figure 4-36 is displayed. If date or time is incorrect, change it using [↑], [↓] keys, [PageUp] key and [PageDown] key. If you want to exit from this page, and go to main menu, hit [ESC] key.

Figure 4-36

STANDARD CMOS SETUP Page



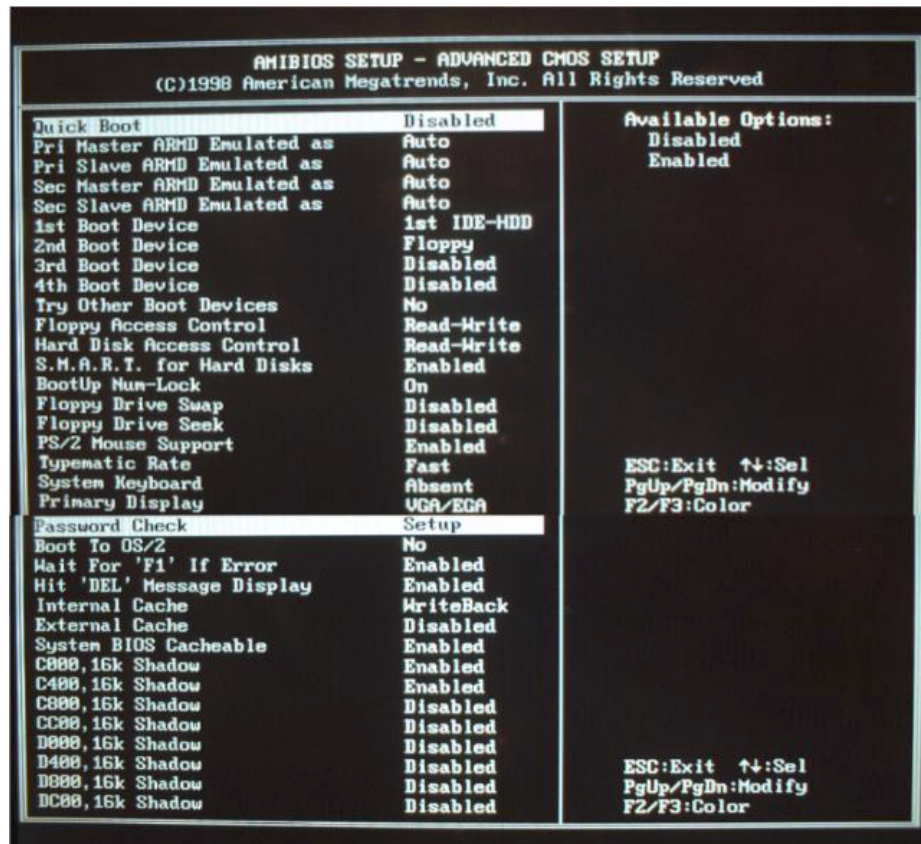
To Configure the A20 Digital Motherboard and BIOS (for serial prefix JP1KH, JP2KH, and MY432)

Advanced CMOS Setup

Advanced CMOS Setup options are displayed by choosing “Standard CMOS Setup” using [↑], [↓] keys and hit [Enter] key at the BIOS setup utility main menu. Then Figure 4-37 is displayed. Compare the default BIOS options as shown in Figure 4-37 with your E4991A’s BIOS options. If there is difference, change BIOS option using [↑], [↓] keys, [PageUp] key and [PageDown] key. If you want to exit from this page, and go to main menu, hit [ESC] key.

Figure 4-37

ADVANCED CMOS SETUP Page



Troubleshooting

To Configure the A20 Digital Motherboard and BIOS (for serial prefix JP1KH, JP2KH, and MY432)

Advanced Chipset Setup

Advanced Chipset Setup options are displayed by choosing “Advanced Chipset Setup” using [↑], [↓] keys and hit [Enter] key at the BIOS setup utility main menu. Then Figure 4-38 is displayed. Compare the default BIOS options as shown in Figure 4-38 with your E4991A’s BIOS options. If there is difference, change BIOS option using [↑], [↓] keys, [PageUp] key and [PageDown] key. If you want to exit from this page, and go to main menu, hit [ESC] key.

Figure 4-38

ADVANCED CHIPSET SETUP page

AMIBIOS SETUP - ADVANCED CHIPSET SETUP	
(C)1998 American Megatrends, Inc. All Rights Reserved	
USB Function	Enabled
USB KB/Mouse Legacy Support	Disabled
Port 64/88 Emulation	Disabled
SDRAM RAS# to CAS# Override	Disabled
SDRAM CAS# Latency	2
SDRAM RAS# Timing	5
SDRAM Speculative Read Logic	Disabled
DRAM Speed	Manual
DRAM Read Burst Timing	x4EDO x4FPM
DRAM Write Burst Timing	x4EDO x4FPM
DRAM Lead Off Timing	11/7/3
Fast EDO Read Cycle Timing	Disabled
Speculative Lead Off Timing	Disabled
Memory Address Drive Strength	10mA, 16mA
Enhanced Paging Disable	Disabled
DRAM Refresh RAS Cycles (HCLK's)	5
DRAM Refresh Rate	15.6 us
Suspend Refresh Type	CBR
Cache DRAM Refresh Time (HCLK's)	8
Memory Hole	Disabled
3bit I/O Recovery Time	Disabled
16bit I/O Recovery Time	Disabled
Clock Chip Spread Spectrum	Disabled

Available Options:
Disabled
Enabled

ESC:Exit ↑:Sel
PgUp/PgDn:Modify
F2/F3:Color

ESC:Exit ↑:Sel
PgUp/PgDn:Modify
F2/F3:Color

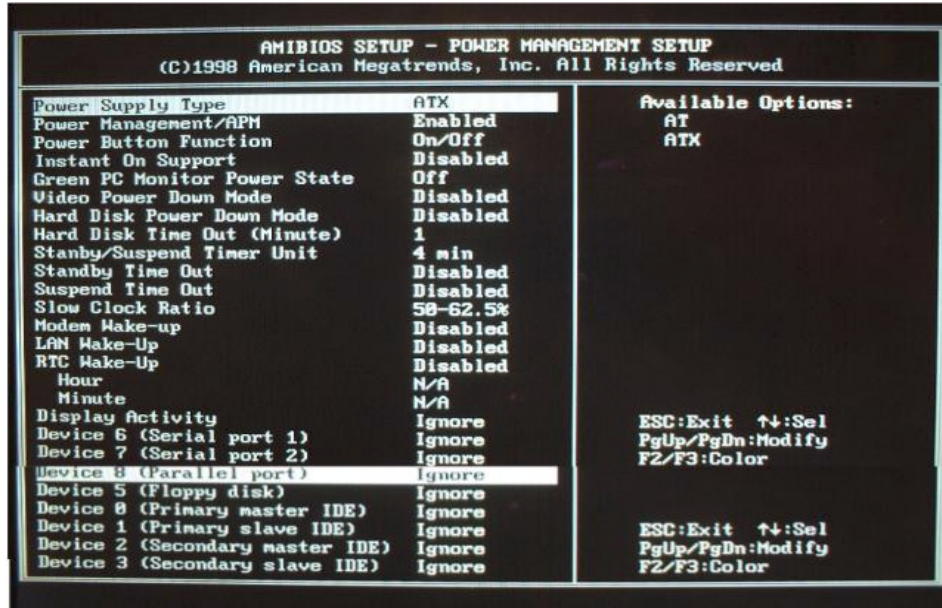
To Configure the A20 Digital Motherboard and BIOS (for serial prefix JP1KH, JP2KH, and MY432)

Power Management Setup

Power Management Setup options are displayed by choosing “Power management Setup” using [↑], [↓] keys and hit [Enter] key at the BIOS setup utility main menu. Then Figure 4-39 is displayed. Compare the default BIOS options as shown in Figure 4-39 with your E4991A’s BIOS options. If there is difference, change BIOS option using [↑], [↓] keys, [PageUp] key and [PageDown] key. If you want to exit from this page, and go to main menu, hit [ESC] key.

Figure 4-39

POWER MANAGEMENT SETUP Page



Troubleshooting

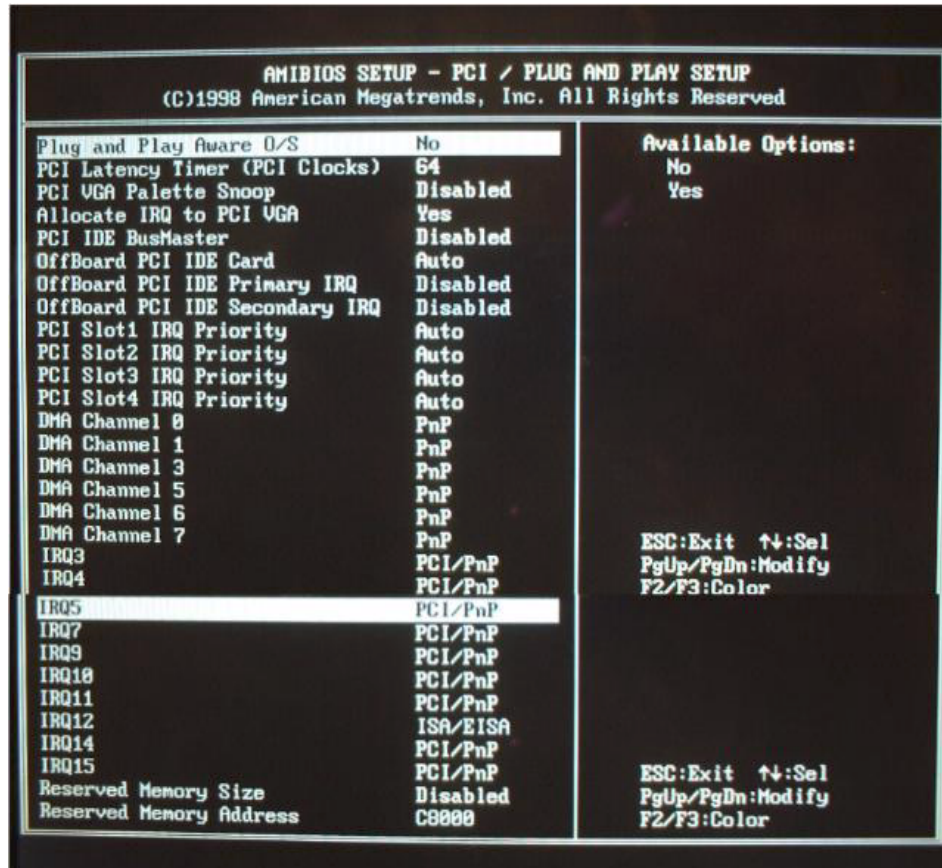
To Configure the A20 Digital Motherboard and BIOS (for serial prefix JP1KH, JP2KH, and MY432)

PCI / Plug and Play Setup

PCI/Plug and Play Setup options are displayed by choosing “PCI / Plug and Play Setup” using [↑], [↓] keys and hit [Enter] key at the BIOS setup utility main menu. Then Figure 4-40 is displayed. Compare the default BIOS options as shown in Figure 4-40 with your E4991A’s BIOS options. If there is difference, change BIOS option using [↑], [↓] keys, [PageUp] key and [PageDown] key. If you want to exit from this page, and go to main menu, hit [ESC] key.

Figure 4-40

PCI / PLUG AND PLAY SETUP Page



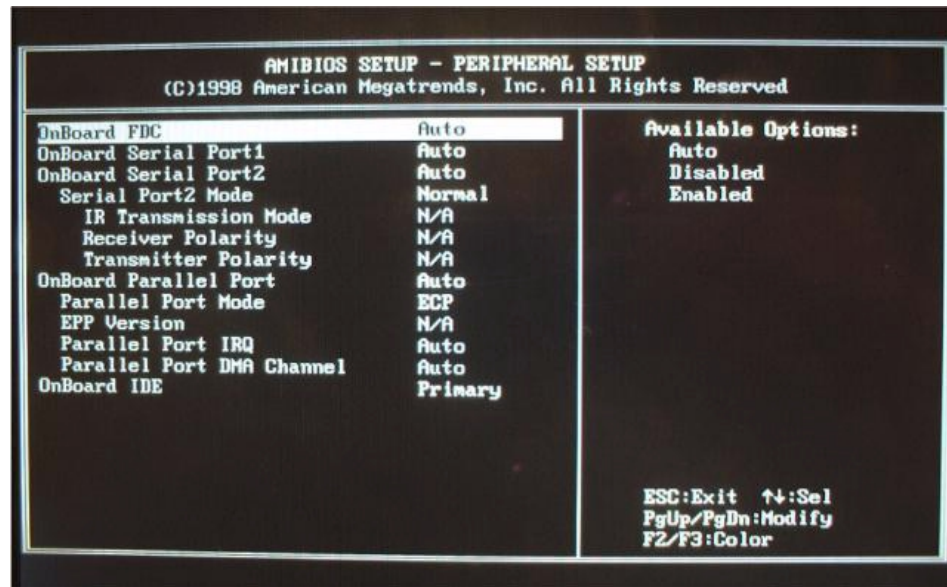
To Configure the A20 Digital Motherboard and BIOS (for serial prefix JP1KH, JP2KH, and MY432)

Peripheral Setup

Peripheral Setup options are displayed by choosing “Peripheral Setup” using [↑], [↓] keys and hit [Enter] key at the BIOS setup utility main menu. Then Figure 4-41 is displayed. Compare the default BIOS options as shown in Figure 4-41 with your E4991A’s BIOS options. If there is difference, change BIOS option using [↑], [↓] keys, [PageUp] key and [PageDown] key. If you want to exit from this page, and go to main menu, hit [ESC] key.

Figure 4-41

PERIPHERAL SETUP Page



Troubleshooting

To Configure the A20 Digital Motherboard and BIOS (for serial prefix JP1KH, JP2KH, and MY432)

Auto-Detect Hard Disks

Auto-Detect Hard Disks options are displayed by choosing “Auto-Detect Hard Disks” using [↑], [↓] keys and hit [Enter] key at the BIOS setup utility main menu. Then Figure 4-42 is displayed. You can find A27 mass storage (hard disk or flash disk) drive parameters for IDE1 drive connected to the primary channel installed in the A20 Digital Motherboard. If you doubt the mass storage doesn't work properly, make sure that the E4991A system detects the mass storage correctly using this option.

Figure 4-42

AUTO-DETECT HARD DISK SETUP Page



To Configure the A20 Digital Motherboard and BIOS (for serial prefix JP1KH, JP2KH, and MY432)

Change Supervisor Password

Usually, you are required a password first, when the BIOS setup utility is executed. If a password is not assigned in your E4991A, set it using BIOS setup utility. Move the cursor to “Change Supervisor Password” using [↑], [↓] keys and hit **[Enter]** key at the BIOS setup utility main menu, and you have to set the password to “e4991a”, don’t set it to others.

Save Settings and Exit

It is necessary to save BIOS options before exit on the BIOS setup utility, when you want to change and save a BIOS option. Move the cursor to “Save Settings and Exit” using [↑], [↓] keys and hit **[Enter]** key at the BIOS setup utility main menu. Then, the message of “Save current settings and exit (Y/N)?” is displayed. If yes, hit **[Y]** key. Then, the BIOS setup utility is closed.

Exit Without Saving

If you cancel the changes of the BIOS options, move the cursor to “Exit Without Saving” using [↑], [↓] keys and hit **[Enter]** key at the BIOS setup utility main menu. Then, the message of “Quit without saving (Y/N)?” is displayed. If you want to quit without saving, hit **[Y]** key. Then, the BIOS setup utility is closed.

To Configure the A20 Digital Motherboard and BIOS (for serial prefix MY433 and later)

When you replace the A20 digital motherboard, you need to confirm the jumper settings for the specific CPU installed. The jumper settings information is provided in “Configure the Motherboard” on page 208.

You also need to confirm the BIOS options using the BIOS setup utility procedure. The BIOS setup procedure is described in “To Confirm or Set the BIOS Options” on page 209.

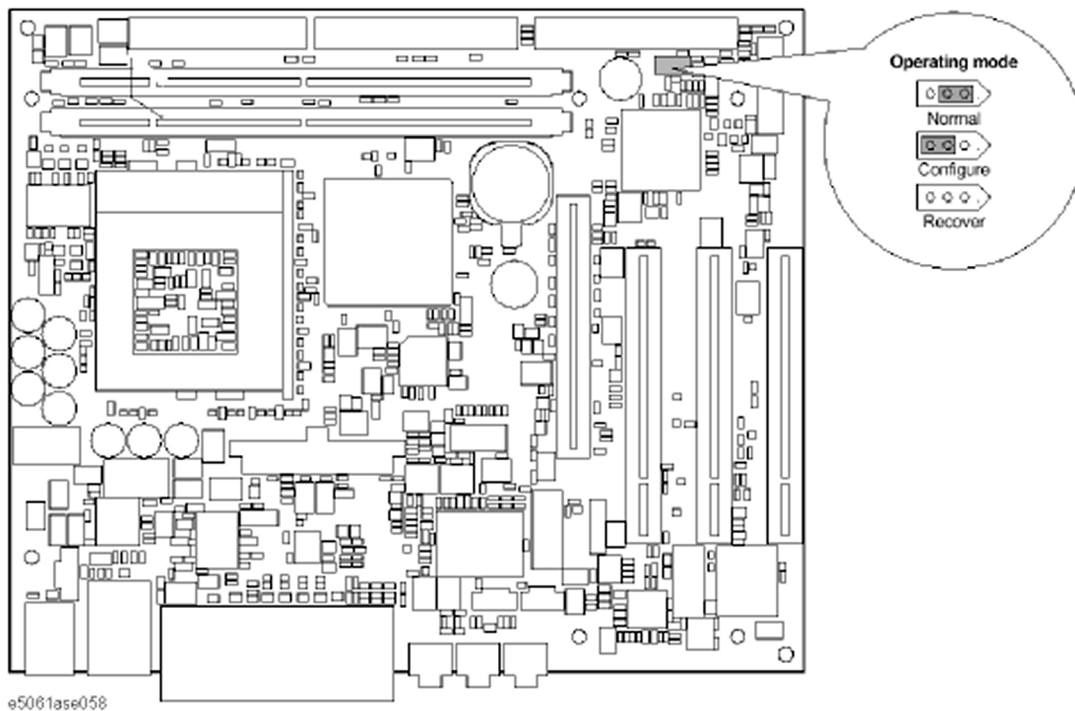
To Identify the Motherboard Installed

Confirm the splash screen is displayed in the beginning of the boot process as shown in Figure 4-15.

Configure the Motherboard

There is a jumper on the A20 digital motherboard that must be configured to the correct setting. Confirm that the jumper setting is “Normal” as shown in Figure 4-43.

Figure 4-43 A20 digital motherboard jumpers location and settings



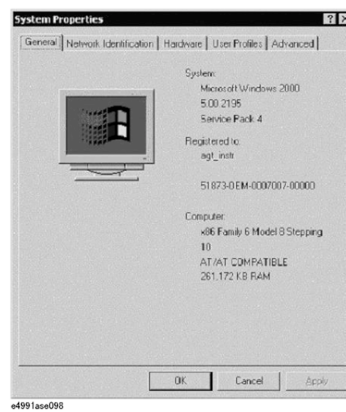
Testing DRAM on the Motherboard

When the A20 digital motherboard is replaced with a new one, it is advisable to perform the DRAM test before proceeding to the BIOS setup utility procedure. Confirm the DRAM count in accordance with the following procedure.

To Configure the A20 Digital Motherboard and BIOS (for serial prefix MY433 and later)

- Step 1.** Connect the external keyboard and mouse to the E4991A rear panel connectors.
- Step 2.** Turn the instrument on. Wait until the E4991A boots up. Do not press any key until the E4991A measurement view appears.
- Step 3.** Press **[System]** key on the front panel.
- Step 4.** Click **Misc Setup** in the softkey menu.
- Step 5.** Click **Control Panel...** in the softkey menu.
- Step 6.** Scroll the function viewer to find "System" icon and double-click "System". This opens "System Properties" window as shown in Figure 4-44.

Figure 4-44 System Properties window



- Step 7.** Verify that "260,148 KB RAM" is displayed in the Computer profile as shown in Figure 4-44. If it is not correct, the A20 board is faulty.
- Step 8.** Click "OK" button to close the window.
- Step 9.** Turn the E4991A off before proceeding to the next step "To Confirm or Set the BIOS Options".

To Confirm or Set the BIOS Options

BIOS is the PC's built-in program describing the standard procedure of basic inputs and outputs for the system hardware. BIOS involves the system BIOS, start-up program and BIOS setup utility. The E4991A starts up first with the BIOS when the power is turned on. Use the following procedure to confirm or set the BIOS options, known as the BIOS setup utility.

Run the BIOS setup utility

Use the external keyboard to select and set various options in the BIOS setup utility. Do not operate the E4991A front panel until you exit the BIOS option setup procedure.

- Procedure**
- Step 1.** Connect the external keyboard to the E4991A rear panel connector.
 - Step 2.** Turn the instrument on.
 - Step 3.** Press F2 key as soon as the splash screen as shown in Figure 4-15 is displayed. Wait a few

To Configure the A20 Digital Motherboard and BIOS (for serial prefix MY433 and later)

seconds until the message "Enter CURRENT Password:" appears.



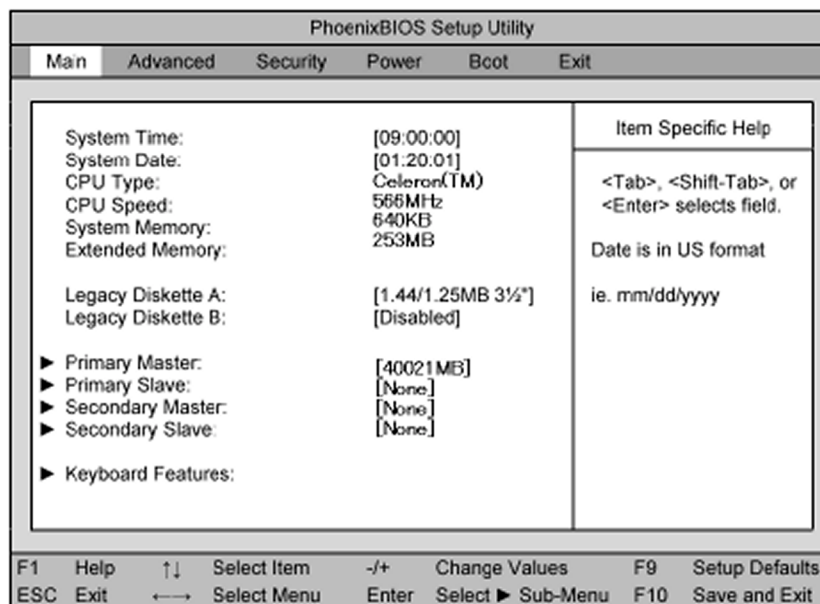





- Step 4.** Press  key (The LED in the key lights.)
- Step 5.** Enter password "e4991a" and press . Then BIOS setup utility main menu is displayed as shown in Figure 4-45.

Figure 4-45

BIOS setup utility main menu



- Step 6.** The BIOS setup utility has primary menus, most of which have sub-menus. Brief descriptions and reference pages for these menus are provided in Table 4-13. The details of the BIOS option settings in each menu and sub-menus are described on the page listed in the table.
- Step 7.** Select a desired menu using   keys. Select a item in the menu or sub-menu window using   keys. To perform an operation, use  key.

NOTE


If you want to quit the BIOS option setting and exit the BIOS setup utility without saving changes in the setup, select "Exit Discarding Changes" and press  key at the Exit Menu.

Table 4-13

BIOS setup utility primary menus and references

Menu	Options	Ref. page
Main	Product description including processor and memory fitted Date and time IDE disks found and sub-menus for extra configuration	on page 210

Table 4-13

BIOS setup utility primary menus and references

Menu	Options	Ref. page
Advanced	Start-up display mode (silent-boot etc.) Operating system type (ACPI etc.) Advanced chipset configuration Processor cache control PCI space configuration I/O devices configuration Advanced hard disk drive options System monitoring Version information	on page 212
Security	Passwords and permissions	on page 214
Power	Action after AC-reconnect Power savings modes and timers	on page 214
Boot	Selects device boot order	on page 213
Exit	Save with or without changes Load/save default settings (from flash ROM)	on page 215

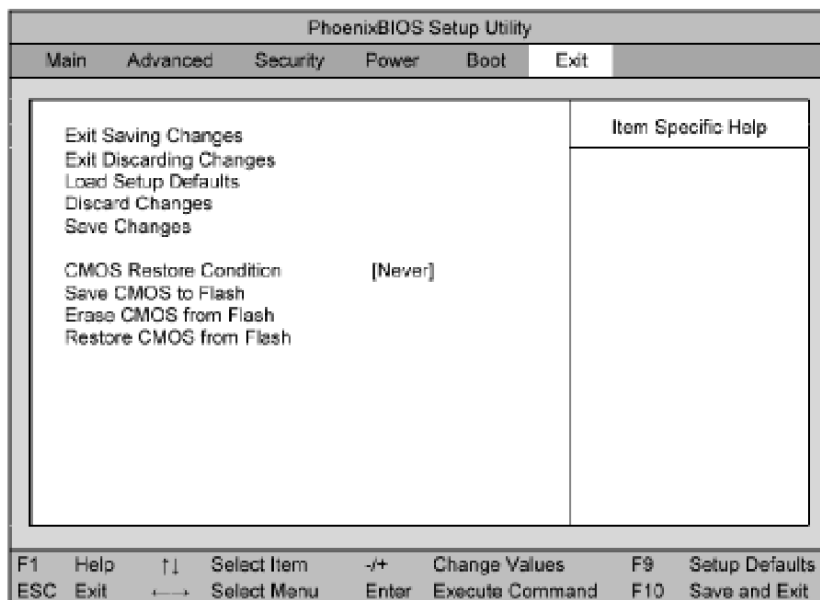
Load Setup Defaults**NOTE**

Perform the following procedure only when the A20 digital motherboard is replaced. Jump to “Advanced Menu” when you check whether the BIOS options are correctly set or not.

Exit menu shown below is displayed by choosing "Exit" using keys and by pressing key at the BIOS Setup Utility main menu. Select “Load Setup Default” using keys. The dialog box “Setup Confirmation” prompts you to select Y (Yes) or N (No). Press and to load the manufacture Setup Defaults into the BIOS ROM. As a result, almost all of the BIOS options are automatically configured to the optimal settings for the E4991A.

Figure 4-46

Exit menu (for Load Setup Defaults)



Advanced Menu

The Advanced Menu shown below is displayed by choosing "Advanced" using keys and by pressing key at the BIOS Setup Utility main menu. Select "Advanced Chipset Control" using keys. The current setup states are displayed as shown in Figure 4-48. If "Video Boot Type" is incorrect, select it using keys, and change the setting by pressing keys.

If you want to exit from this page and return to main menu, press key.

Figure 4-47

Advanced Menu

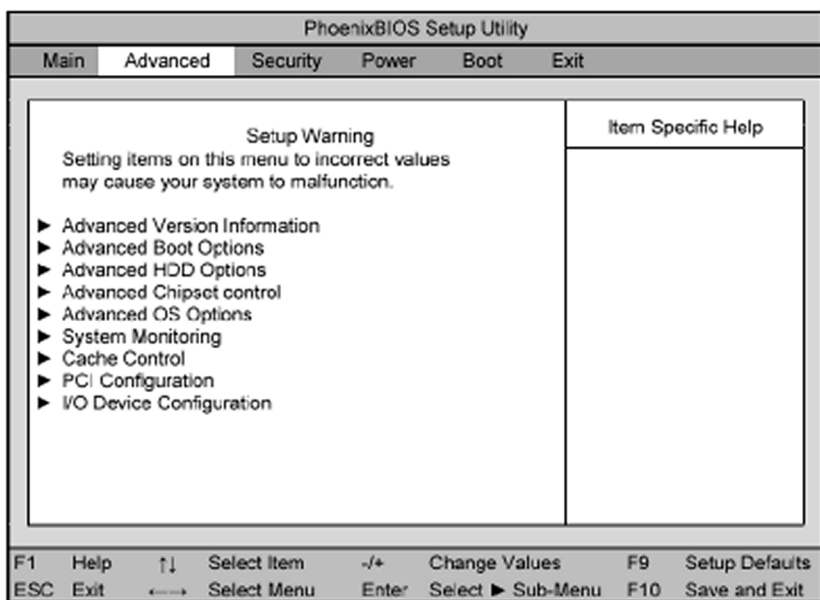
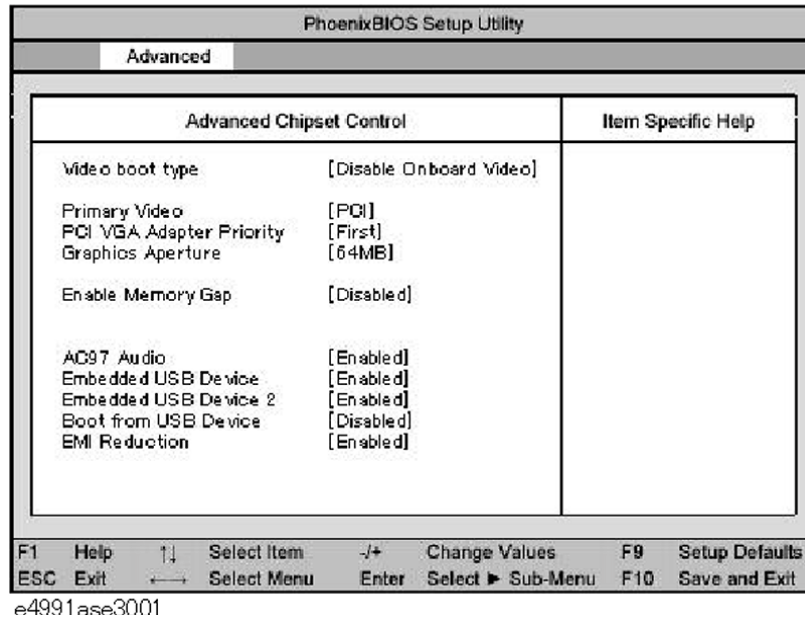


Figure 4-48

Advanced Chipset Control Sub-menu

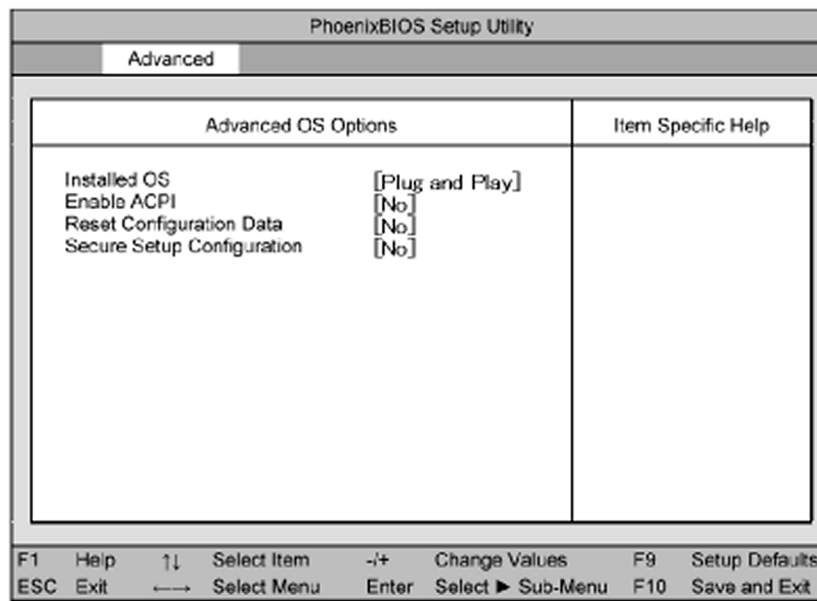


Next, select “Advanced OS Options” using **↑** **↓** keys. The current setup states are displayed as shown in Figure 4-49. If “Installed OS” or “Enable ACPI” is incorrect, select it using **↑** **↓** keys, and change the setting by pressing **+** **-** keys.

If you want to exit from this page and return to main menu, press **Esc** key.

Figure 4-49

Advanced OS Options Sub-menu







Boot Menu

The Boot Menu shown below is displayed by choosing "Boot" using **←** **→** keys and by pressing **Enter** key at the BIOS Setup Utility main menu. The current setup states are

Troubleshooting

To Configure the A20 Digital Motherboard and BIOS (for serial prefix MY433 and later)

displayed as shown in Figure 4-50. If the setup is incorrect, select it using   keys, and change the setting by pressing   keys.


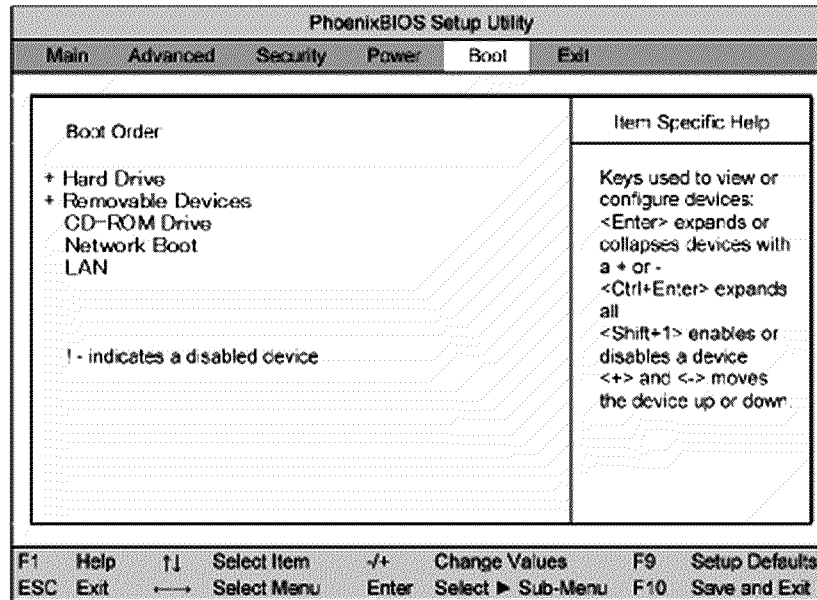
If you want to exit from this page and return to main menu, press  key.









Figure 4-50

Boot Menu










Change Supervisor Password

A password needs to be entered to execute the BIOS setup utility. If a password has not been assigned in the E4991A, set the password using this BIOS setup utility as follows.

- Select "Security" using   keys at the BIOS Setup Utility main menu and press  key.
- Select "Set Supervisor password" using   keys and press  key.
- Enter the password of "e4991a". Never set another password.
- Press  key.
- If a message of "New supervisor password installed. Press any key to continue" is displayed, press  key.

Power Menu

The Power Menu shown below is displayed by choosing "Power" using   keys and by pressing  key at the BIOS Setup Utility main menu. The current setup states are displayed as shown in Figure 4-51. If "After Power Failure" is incorrect, select it using   keys, and change the setting by pressing   keys.


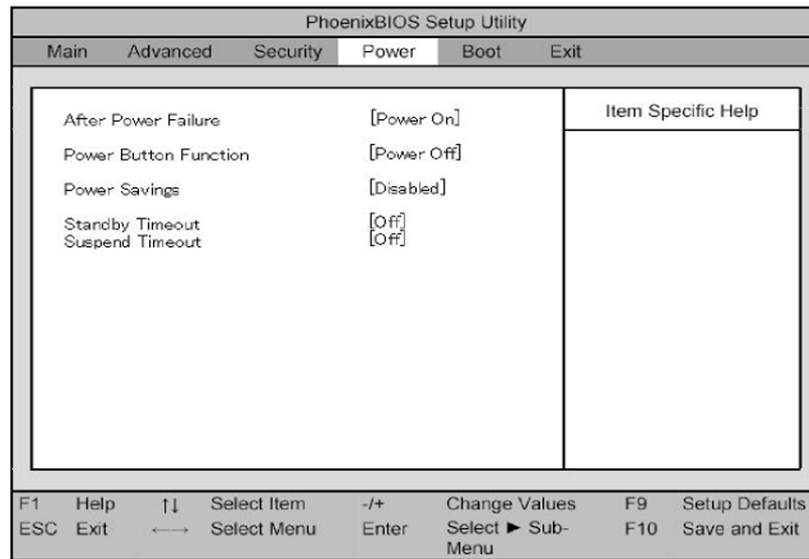
If you want to exit from this page and return to main menu, press  key.

Figure 4-51

Power Menu



Save & Exit Setup When you want to change and save a BIOS option, Select "Exit" using keys at the BIOS Setup Utility main menu and press key. Select "Save CMOS to Flash" using and press key. Then select "Exit Saving Changes" using and press key. A message of "Save configuration change and exit now?" is displayed. Select "Yes" using and press key.

The BIOS setup utility is closed after the current settings are saved.

Exit Without Saving

If you cancel the changes in the BIOS option settings, select "Exit Discarding Changes" using keys at the Exit Menu and press key.

The BIOS setup utility is closed without saving the current settings.

Troubleshooting

To Configure the A20 Digital Motherboard and BIOS (for serial prefix MY433 and later)

5 Theory of Operation

This chapter provides the theory of operation of the E4991A RF Impedance/Material Analyzer.

Overall Instrument Operation

The E4991A consists of a mainframe, a test head and a calibration kit as shown in Figure 5-1. The mainframe includes a signal source, a receiver, a digital control, and a power supply section.

The signal source generates a stimulus signal in the frequency range from 1 MHz to 3 GHz. The stimulus signal goes through the test head, and the test fixture to the device under test (DUT).

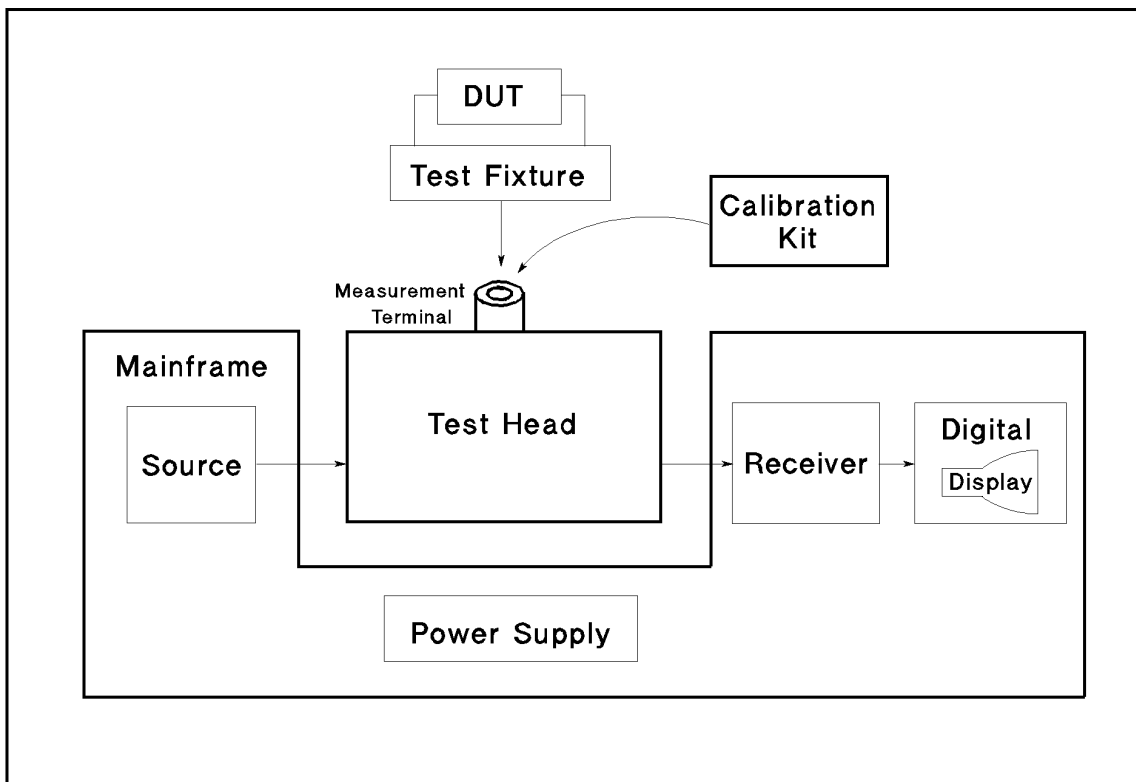
The test head detects the voltage across the DUT and the current through the DUT, and transfers the detected signals to the receiver section.

The receiver converts the analog signals to a digital data and forwards it to the digital control section.

The calibration kit is used to calibrate the E4991A system. Calibration ensures the impedance measurement accuracy at the measurement terminal of the test head.

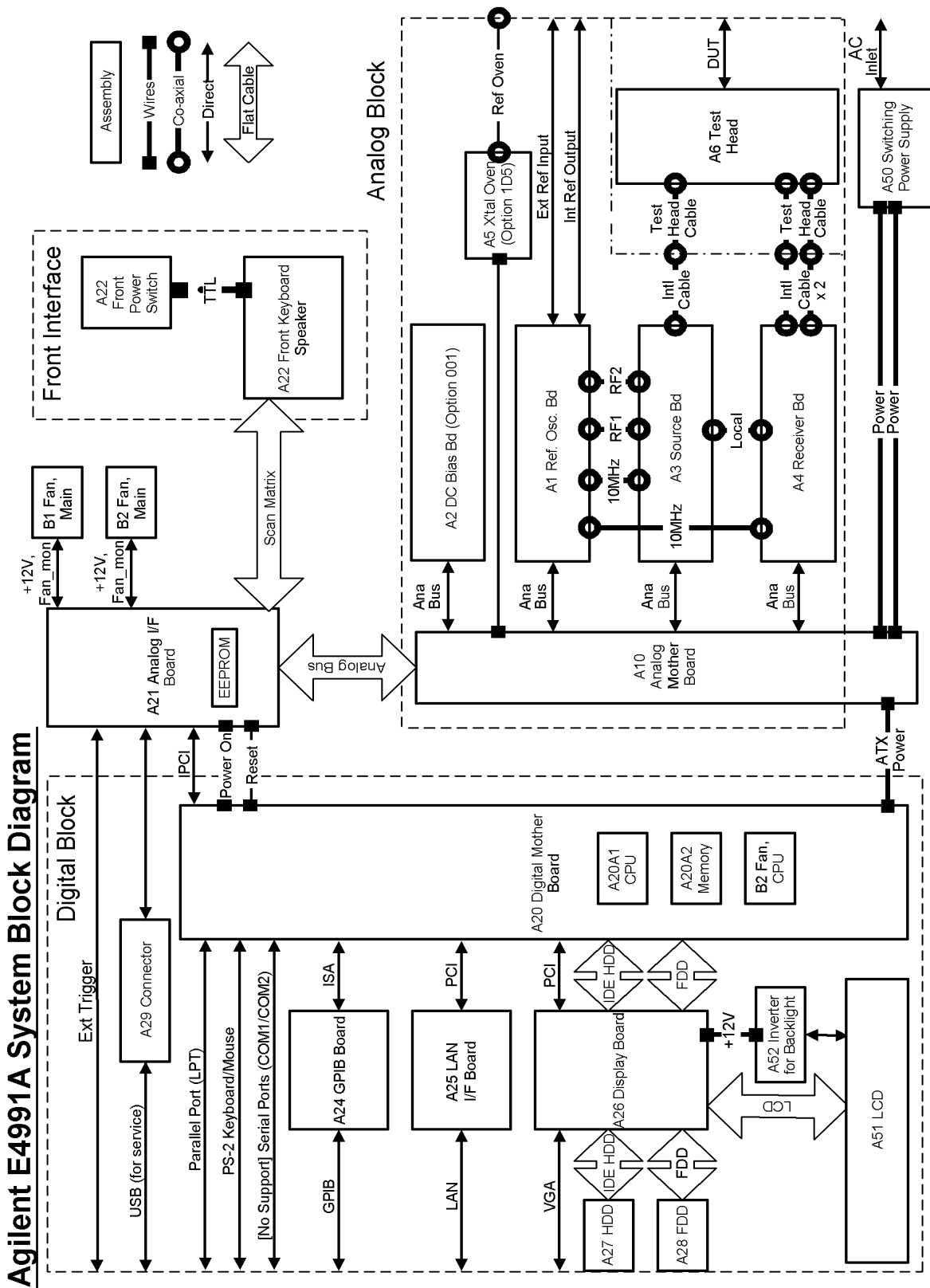
The power supply in the mainframe supplies all necessary dc power for the E4991A.

Figure 5-1



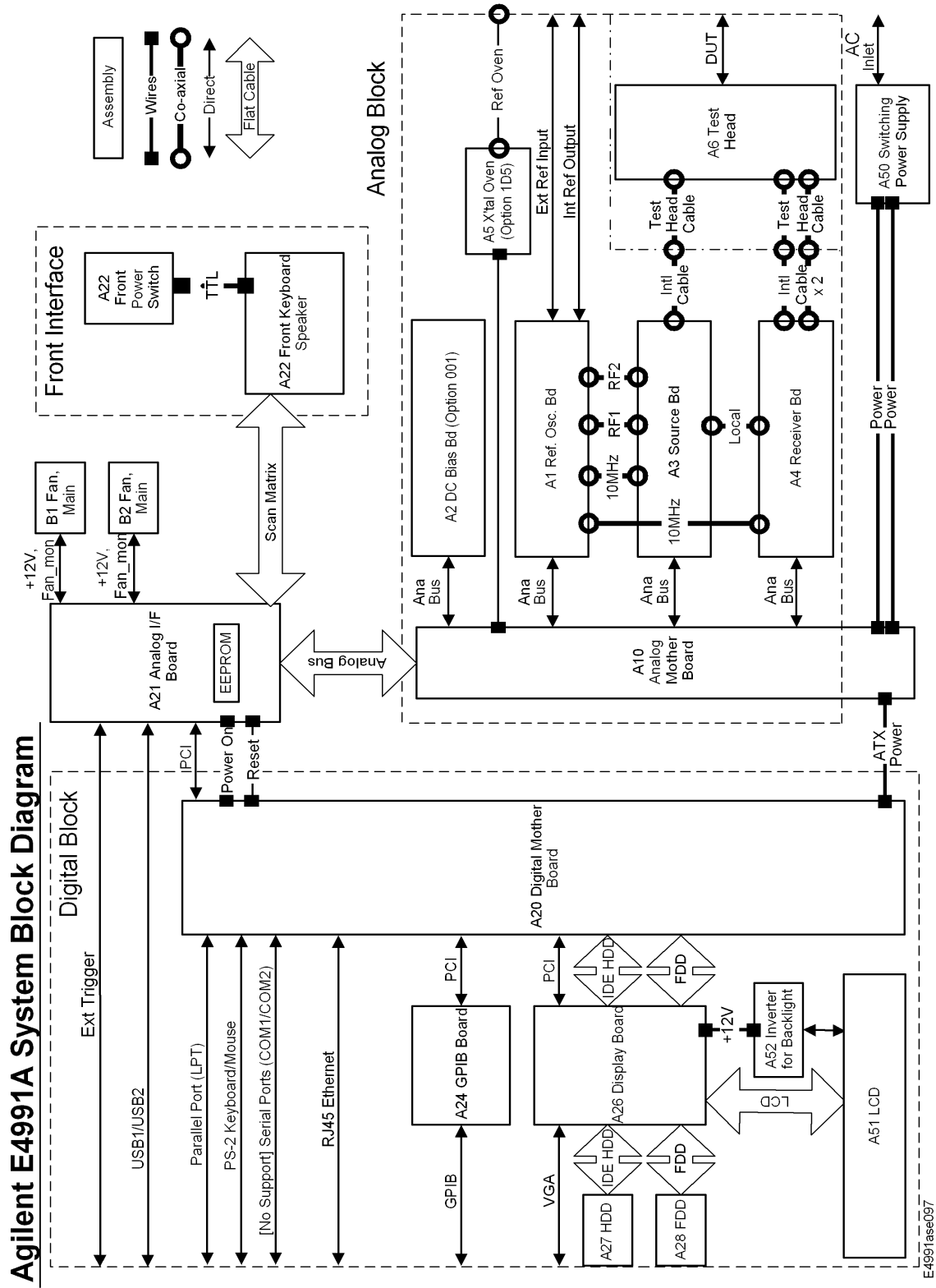
Connection between each assembly in the mainframe is shown in Figure 5-2 system block diagram.

Figure 5-2 System Block Diagram (for serial prefix JP1KH, JP2KH, and MY432)



e4991ase012

Figure 5-3 System Block Diagram (for serial prefix MY433 and later)



Digital Section

A20 Digital Motherboard (for serial prefix JP1KH, JP2KH, and MY432)

A20 digital motherboard provides basic system control and interface functions for the instrument. It contains a CPU, ROM for BIOS, 128MBytes RAM, USB interface, keyboard and mouse interfaces, and interfaces to PCI (Peripheral Component Interconnect) and ISA (Industry Standard Architecture) buses.

A20 Digital Motherboard (for serial prefix MY433 and later)

A20 digital motherboard provides basic system control and interface functions for the instrument. It contains a CPU, ROM for BIOS, 256MBytes RAM, USB interface, LAN, keyboard and mouse interfaces, and interfaces to PCI (Peripheral Component Interconnect) buses.

A21 Analog Interface Board

A21 analog interface board has several functions: an interface function between digital and analog blocks, the other interface functions for A22 front panel keyboard, a power control function, and measurement function. The A21 contains PLD (Programmable Logic Device) for interface functions, a BNC connector for external trigger input, DSP (Digital Signal Processor) for post measurement data processing and EEPROM that stores correction constants for adjustment data.

A22 Front Panel Keyboard

A22 front panel keyboard detects operator's inputs, key inputs and RPG inputs, from the front panel, and transmits them to the A21 analog interface board.

A24 GPIB Board

A24 GPIB board provides IEEE-488 standard bus services for instrument. The board interfaces the bus to A20 digital motherboard to receive and process GPIB commands.

A25 LAN Interface Board (for serial prefix JP1KH, JP2KH, and MY432)

A25 LAN interface board allows the analyzer to communicate with an external controller or an external server via a network interconnection. Protocol is TCP/IP, and it works for 10base-T and 100base-TX.

A26 Display Board

A26 display board controls LCD. The control signals are transmitted through a flat cable, and a backlight voltage is supplied through A52 inverter board.

A27 Mass Storage Disk Drive

A27 mass storage disk drive is a 2.5 inches hard disk drive. The disk drive is used to store the operating system, firmware, and user's measurement data. The drive is mounted with shock-resistance, but be careful for the mechanical handling.

A28 FDD (Floppy Disk Drive)

A28 FDD is a 1.44 MBytes, 3.5 inches, MS-DOS compatible, and it is located on the front panel. The FDD is used to store the measurement data and the instrument setup data.

A51 LCD (Liquid Crystal Display)

A51 is an 8.4 inch color TFT LCD. It consists of the LCD display and the backlight. Video signal is provided from A26 Display Board through a flat cable.

A high voltage is supplied from A52 Inverter to the LCD's backlight. The backlight determines the brightness of the LCD screen.

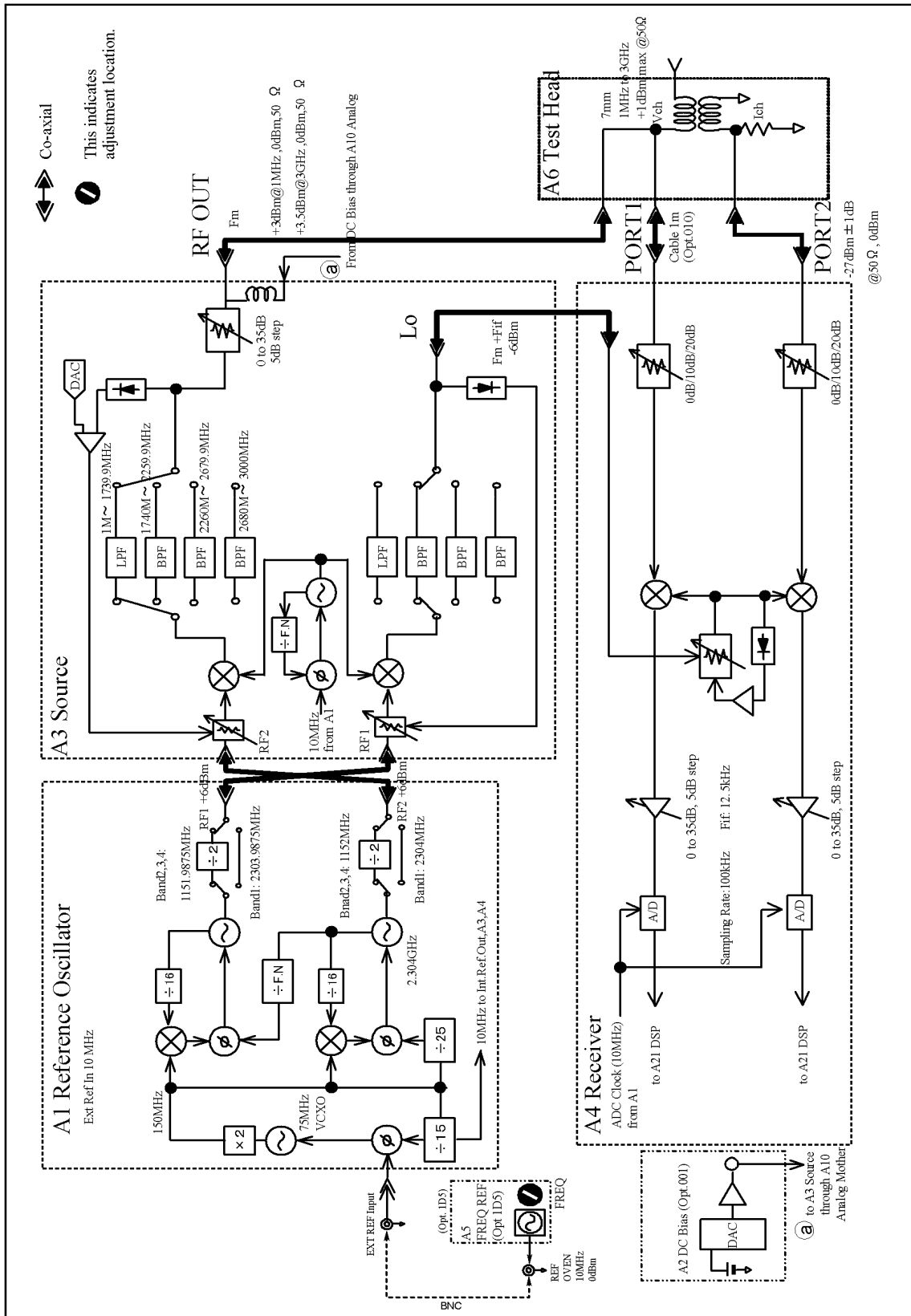
A52 Inverter Board

A52 generates a high ac voltage required to drive LCD's backlight.

Analog Section

The analog section consists of A1 reference osc board, A2 DC bias board(Option 001), A3 source board, A4 receiver board, A5 reference oven board(Option 1D5), A6 test head, and A10 analog motherboard. The A1, A2, A3, and A4 are controlled by A20 digital motherboard through A21 analog interface board and A10 analog motherboard.

Figure 5-4 Analog Block Diagram



e4991ase011

A1 Reference Oscillator Board

A1 reference oscillator board provides reference frequencies of RF1, RF2, Int Ref Out, and 10 MHz reference for A3 and A4.

The RF1 is supplied to A3 source board for local signal that will be supplied to A4 finally, and its frequency depends on measurement frequency as shown in Table 5-1. The signal level of the RF1 is +6 dBm typically. The RF2 is supplied to A3 for producing the measurement signal that is output from RF OUT port. The signal level of the RF2 is +6 dBm typically. The frequency difference between RF1 and RF2 is 12.5 kHz equal to the IF signal.

Table 5-1 RF1 and RF2 frequencies for each band

	Measurement Frequency	RF1	RF2
Band1	1 MHz – 1739.9 MHz	2303.9875 MHz	2304 MHz
Band2	1740 MHz – 2259.9 MHz	1151.9875 MHz	1152 MHz
Band3	2260 MHz – 2679.9 MHz	1151.9875 MHz	1152 MHz
Band4	2680 MHz – 3000 MHz	1151.9875 MHz	1152 MHz

A 150MHz oscillator(75MHz VCXO x 2) in A1 supplies a reference frequency signal for the PLL-controlled oscillators that create RF1 and RF2 signals. If nothing is connected to Ext Ref In connector on the rear panel, it is locked to an internal VCXO (Voltage Controlled Crystal Oscillator). But if an external 10 MHz signal is supplied to the Ext Ref In, it is locked to the external signal.

The RF2 is generated by a PLL circuit with the 6MHz reference signal (150MHz reference signal / 25). The RF1 is generated by a PLL circuit with the reference signal that is the RF2 divided by the fractional N divider. If one of the VCO control voltages in the PLLs is out of limits, “PLL Unlock” notification is displayed.

The created 150 MHz signal is also divided into a 10 MHz signal(150MHz/15), and it is supplied to A3 and A4 for reference frequency through A10 analog motherboard. The 10MHz reference signal is output to Int Ref Out BNC connector on the rear panel directly.

A3 Source Board

A3 source board supplies a measurement signal through RF OUT port to A6 test head, and a local signal to A4 receiver board. A3 source board also supplies a DC bias voltage which is generated by A2 DC bias board(Opt.001), through RF OUT port to A6 test head.

VCO (Voltage Controlled Oscillator) frequency varies from 2305 MHz to 4152 MHz, and it is mixed with RF2 signal to produce the measurement frequency(1MHz to 3GHz). The relationship of the VCO frequency and measurement frequency is shown in Table 5-2. After the mixing, the signal is filtered with a selectable BPF (Band Pass Filter) or a LPF (Low Pass Filter) to eliminate the unwanted harmonics and spurious.

Table 5-2 VCO and measurement frequencies for each band

	Measurement Frequency	VCO Frequency
Band1	1 MHz – 1739.9 MHz	2305 MHz – 4043.9 MHz
Band2	1740 MHz – 2259.9 MHz	2892 MHz – 3411.9 MHz
Band3	2260 MHz – 2679.9 MHz	3412 MHz – 3831.9 MHz
Band4	2680 MHz – 3000 MHz	3832 MHz – 4152 MHz

The filtered signal goes through an attenuator variable from 0 dB to 35 dB in 5 dB steps, and is output to RF Out port. Attenuation is controlled depending on the output power setting as shown in Table 5-3.

Table 5-3 Output Attenuator

Nominal Setting of Output Power Level	Output Attenuator on A3
-7.9 dBm ~ +1 dBm	0 dB
-12.9 dBm ~ -8 dBm	5 dB
-17.9 dBm ~ -13 dBm	10 dB
-22.9 dBm ~ -18 dBm	15 dB
-27.9 dBm ~ -23 dBm	20 dB
-32.9 dBm ~ -28 dBm	25 dB
-37.9 dBm ~ -33 dBm	30 dB
-40 dBm ~ -38 dBm	35 dB

The A3 VCO signal is also mixed with RF1 signal which is supplied to A4 receiver board.

A4 Receiver Board

A4 receiver board receives the Vch and Ich signals from the A6 test head through PORT1 and PORT2, mixes down them into 12.5KHz IF signals, and converts the analog signals to digital data. The receiver has two signal flow to measure Vch and Ich signals.

The input attenuators on A4 board are controlled to optimize the receiver input signal levels(the signal to noise ratios) for accurate measurements. These attenuators are set depending on the output power setting as shown in Table 5-4.

Table 5-4

Input Attenuator

Nominal Setting of Output Power Level	Input Attenuator on A4
-12.9 dBm ~ +1 dBm	20 dB
-22.9 dBm ~ -13 dBm	10 dB
-40 dBm ~ -23 dBm	0 dB

The variable gain IF amplifiers automatically control the IF signal levels to be within appropriate range for the input of the ADC (analog to digital converter).

The digitized data at ADC is transferred through A10 analog motherboard to the DSP on A21 analog interface board which performs vector component extraction and calculation for the Vch and Ich signal data.

A6 Test Head Board(for the standard and Option 010)

A6 test head receives the stimulus signal from the A3 source board through RFOUT port and test cable(Opt.010), and applies it to the DUT (device under test). At the same time, the test head outputs two signals(Vch and Ich signals) that represent the voltage across the DUT and the current through the DUT.

A10 Analog Motherboard

A10 analog motherboard connects A1, A2, A3, and A4 to A21 analog interface board.

A2 DC Bias Board (Option 001)

A2 DC bias board contains a DC bias source that provides a bias voltage up to 40V and a bias current up to 100 mA.

The bias voltage across the DUT and the bias current through the DUT are monitored and feedback to the bias source. This feedback operation automatically maintains the bias voltage or current at the same level as the setting value regardless of the DUT's dc resistance. The bias source allows a current compliance(limit) to be applied in the voltage bias mode and a voltage compliance in the current bias mode.

A5 Reference Oven Board (Option 1D5)

A5 reference oven board supplies a high stability 10MHz external reference signal to A1 reference oscillator board via an external connection path between rear panel BNC connectors. When the 10MHz external reference output (Option 1D5) is connected to the EXT REF Input connector on the rear panel, the internal REF OSC output signal is phase locked to the external reference signal.

6 Replaceable Parts

This chapter contains information for ordering replacement parts for the E4991A RF Impedance/Material Analyzer.

Ordering Information

To order part listed in the replaceable part lists, quote the Agilent part number (with a check digit), indicate the quantity required, and address the order to the nearest Agilent office. The check digit will ensure accurate and timely processing of the order.

To order a part not listed in the replaceable part table, include the instrument model number, the description and function of the part, and the quantity of parts required. Address the order to the nearest Agilent office.

Direct Mail Order System

Within the USA, Agilent can supply parts through a direct mail order system. There are several advantages to this system:

- Direct ordering and shipping from the Agilent Parts Center in Mountain View, California.
- No maximum or minimum on any mail order (there is a minimum order amount for parts ordered through a local Agilent office when the orders require billing and invoicing)
- Prepaid transportation (there is a small handling charge for each order).
- No invoices.

In order for Agilent to provide these advantages, please send a check or money order with each order.

Mail order forms and specific ordering information are available through your local Agilent sales office. Addresses and telephone numbers are located in a separate document shipped with the manuals.

Exchange Assemblies

Under the rebuilt-exchange assembly program, certain factory-repaired and tested assemblies are available on a trade-in basis. These assemblies are offered at lower cost than a new assembly, but meet all factory specifications required of a new assembly.

The defective assembly must be returned for credit under the terms of the rebuilt-exchange assembly program. Any spare assembly stock desired should be ordered using the new assembly part number.

Replaceable Parts List (for serial prefix JP1KH, JP2KH, and MY432)

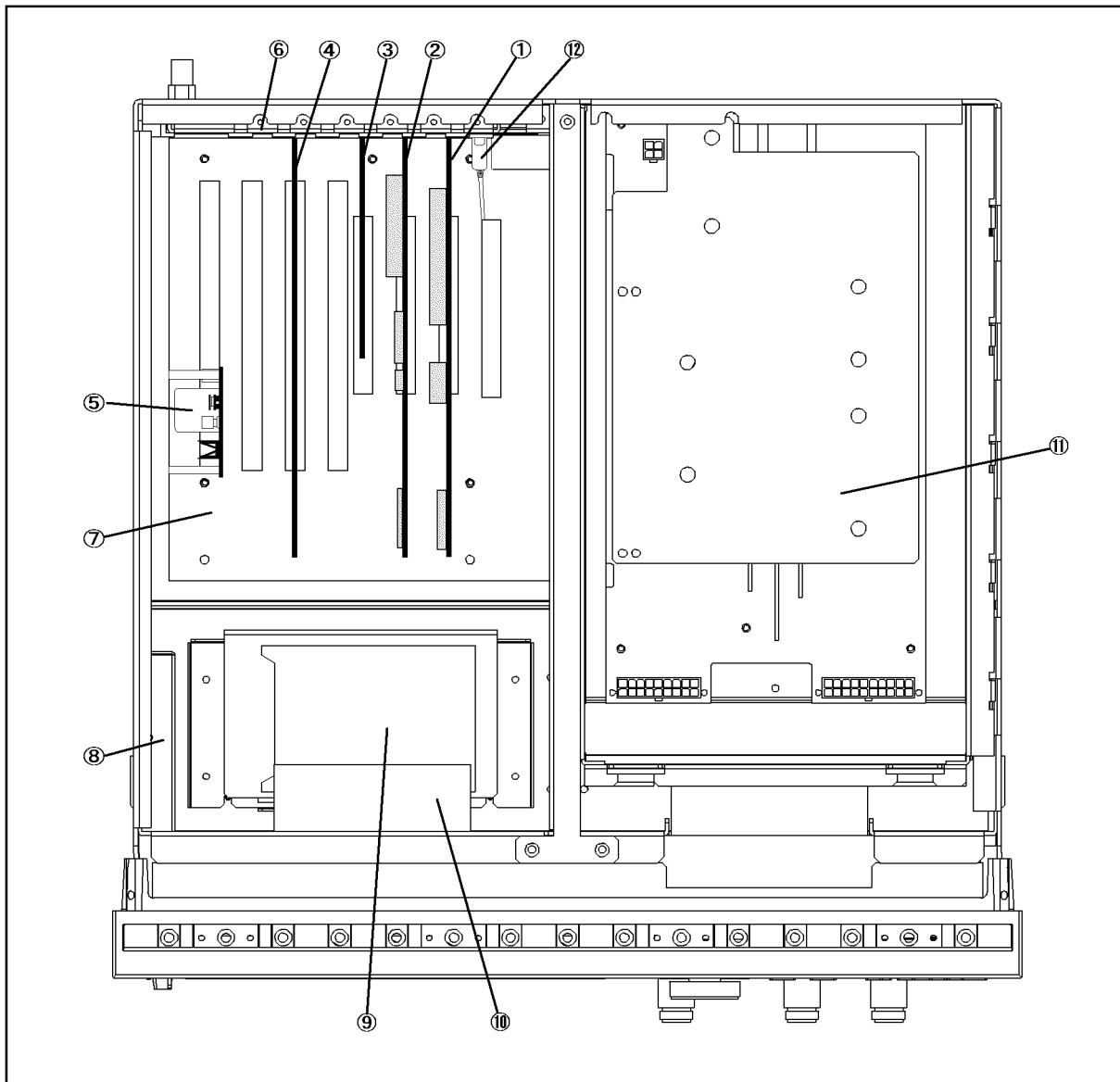
Power Cables and Plug Configurations

For details of the power cables and plug configurations, refer to Appendix D, “Power Requirement,” on page 331.

Top View (Major Assembly)

Figure 6-1

Top View (Major Assembly)



e4991ase024

Table 6-1 Top View (Major Assembly)

Ref. Desig.	Agilent Part Number	C/D	Qty.	Description
1	04287-66521	7	1	A21 ANALOG INTERFACE BOARD
	1818-6491	1	1	IC, EEPROM*1
	0515-0430	3	1	SCREW M3
2	54810-66413	6	1	A26 DISPLAY BOARD
	04287-87101	3	1	LABEL
	0515-0430	3	1	SCREW M3
3	1150-7769	2	1	A25 LAN BOARD
	0515-0430	3	1	SCREW M3
4	82341C #002	8	1	A24 GPIB BOARD
	0515-0430	3	1	SCREW M3
5	E4991-66505	7	1	A5 10MHz OVEN (Opt. 1D5)
	0515-0914	8	3	SCREW-MACH M3X0.5
6	04287-01210	5	2	SLOT COVER
	0515-0430	3	2	SCREW M3
7	E4991-61020	1	1	A20 ATX DIGITAL MOTHER BOARD
	0515-1250	7	6	SCREW M3X0.5
	0380-1811	9	1	STAND OFF
8	0950-2782	4	1	A28 FLOPPY DISK DRIVE
	04287-01203	6	1	FDD HOLDER
	0515-1056	1	3	SCREW
	0515-1550	0	4	SCREW M3-L 8 P-H
9	See Table 6-13		1	Mass Storage Disk Drive Assembly
	0515-1550	0	4	SCREW M3-L 8 P-H
10	04287-61001	8	1	FAN ASSY
	0515-1666	9	4	SCREW M4X35 POZI
11	See Table 6-14		1	A50 Power Supply Assembly
12	E4991-61001	8	1	PORT USB
	1400-0249	0	1	CABLE TIE
	0515-1250	7	1	SCREW

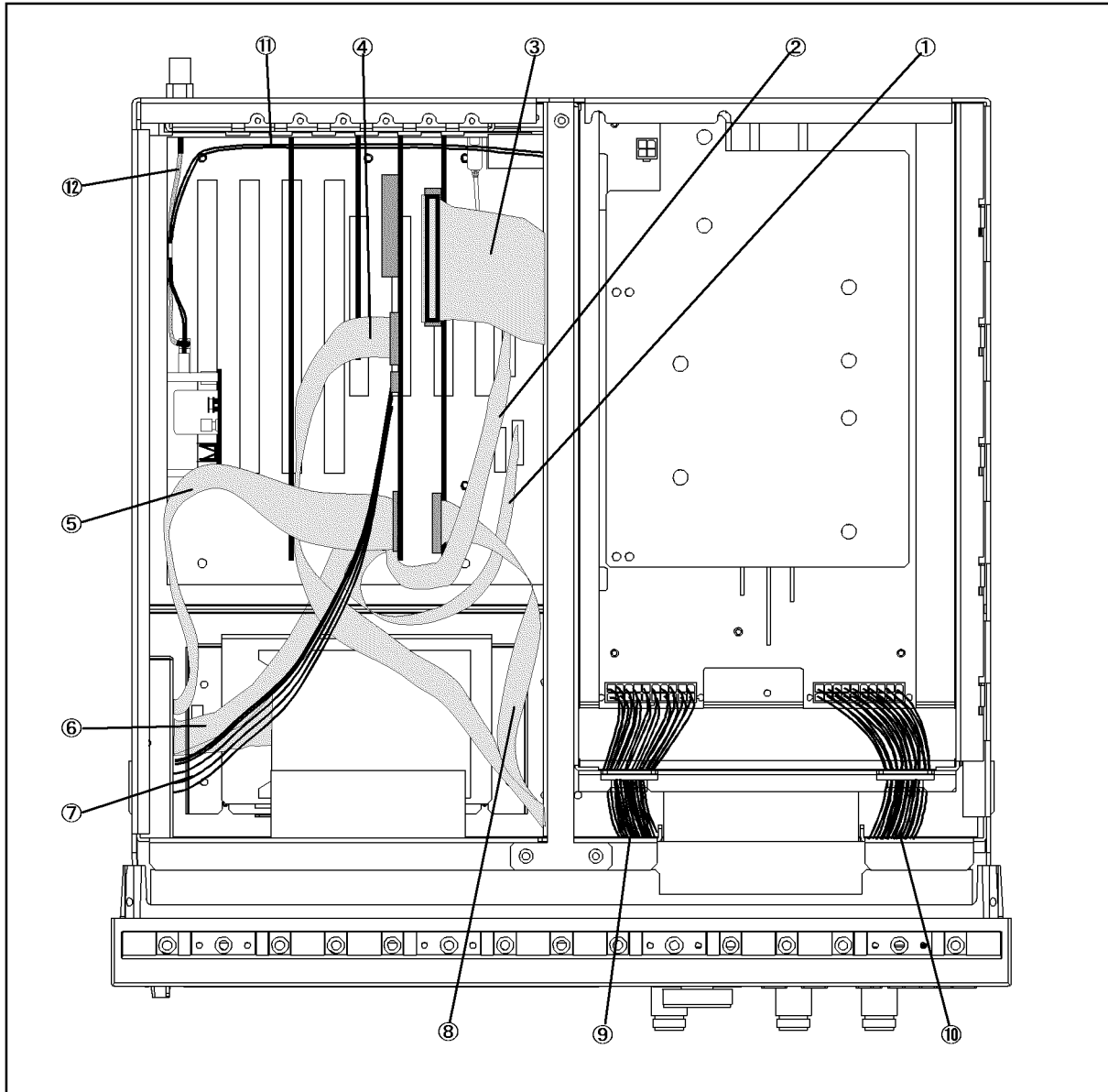
Replaceable Parts

Replaceable Parts List (for serial prefix JP1KH, JP2KH, and MY432)

*1. Included in the analog Interface board.

Top View (Cables & Other Parts)

Figure 6-2 Top View (Cables & Other Parts)



e4991ase023

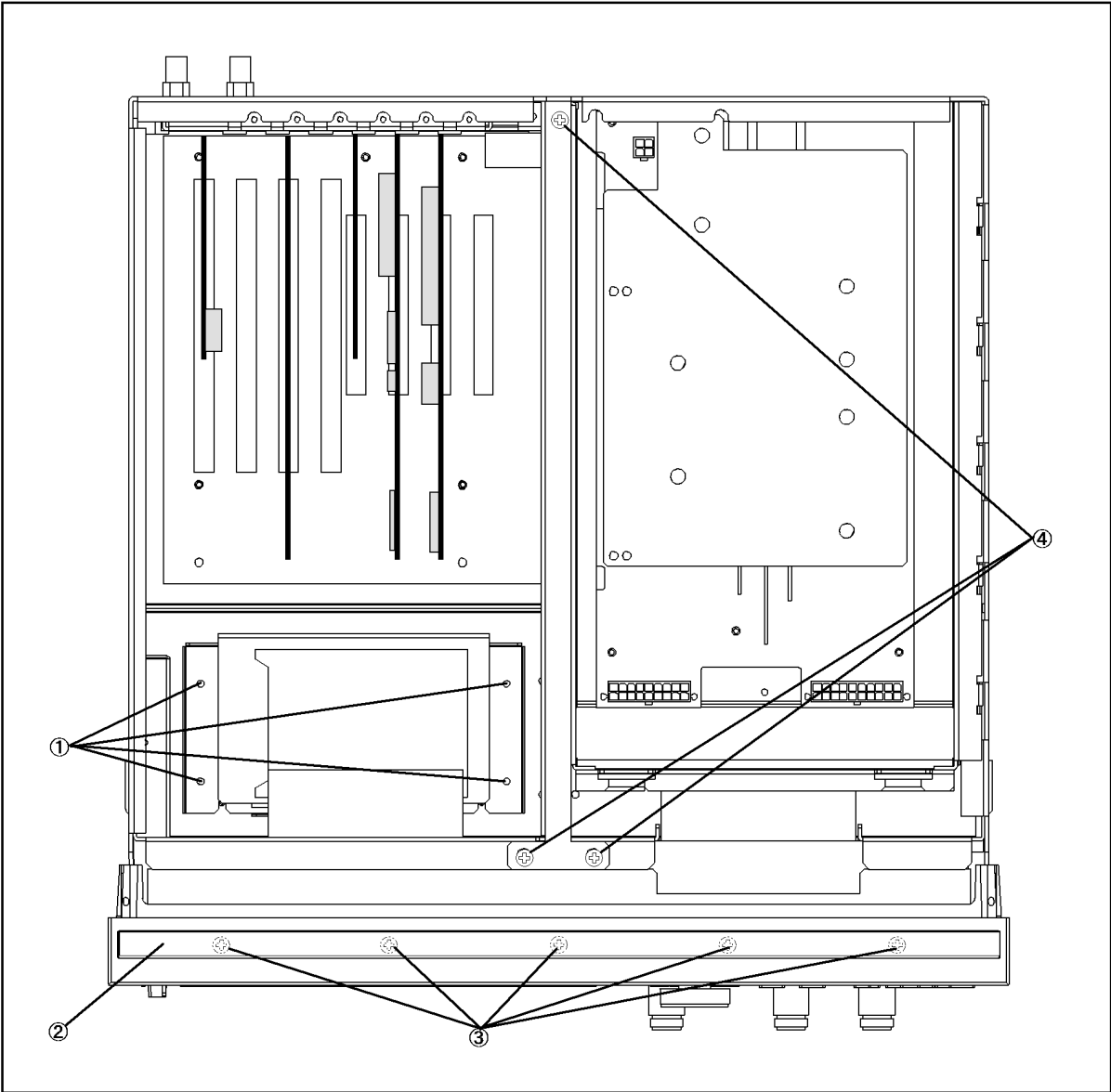
Replaceable Parts List (for serial prefix JP1KH, JP2KH, and MY432)

Table 6-2 Top View (Cables)

Ref. Desig.	Agilent Part Number	C/D	Qty.	Description
1	54801-61611	5	1	FLAT CABLE ASSY
2	54801-61610	4	1	FLAT CABLE ASSY
3	04396-61707	3	1	CABLE ASSY
4	04287-61607	0	1	FLAT CABLE
5	E5100-61661	1	1	CABLE FLAT 26PIN
6	54801-61636	4	1	FLAT CABLE ASSY
7	54801-61635	3	1	WIRE ASSY
8	04287-61609	2	1	FLAT CABLE ASSY
9	04287-61632	1	1	WIRE ASSY
10	04287-61633	2	1	WIRE ASSY
11	E4991-61606	9	1	WIRE ASSY
12	E4991-61605	8	1	RF CABLE ASSY

Top View (Miscellaneous Parts)

Figure 6-3 Top View (Miscellaneous Parts)



4287ase06010

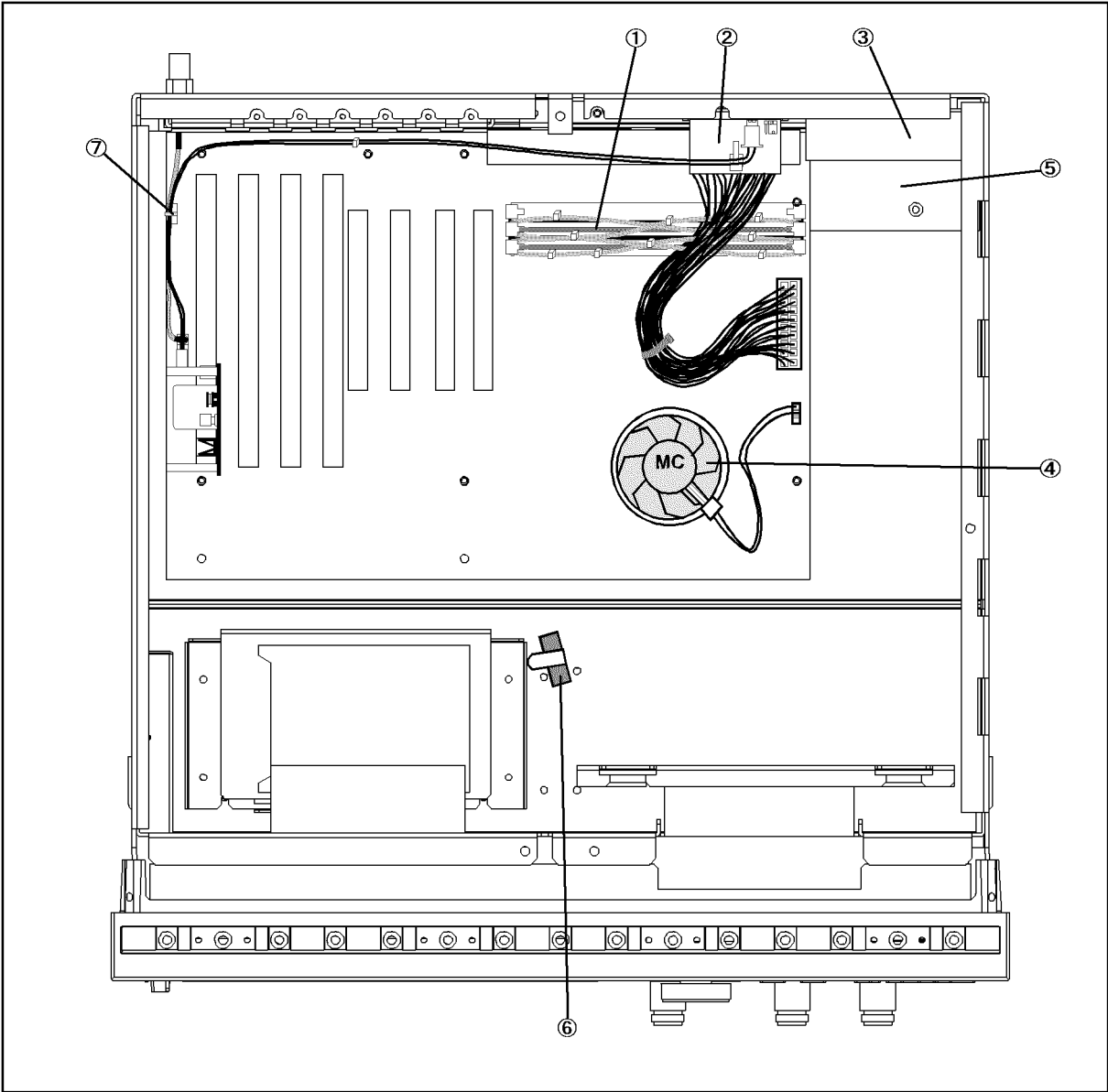
Table 6-3 Top View (Screw)

Ref. Desig.	Agilent Part Number	C/D	Qty.	Description
1	0515-1550	0	4	SCREW M3-L 8 P-H
2	5041-9176	2	1	TRIM STRIP
3	0515-0889	6	5	SCREW-MACH M3.5X.6
	0515-0889	6	6	SCREW-MACH M3.5X.6 (Bottom Side)
4	0515-0914	8	3	SCREW-MACH M3X0.5

Replaceable Parts
Replaceable Parts List (for serial prefix JP1KH, JP2KH, and MY432)

Top View (Under Power Supply)

Figure 6-4 Top View (Under Power Supply)



e4991ase025

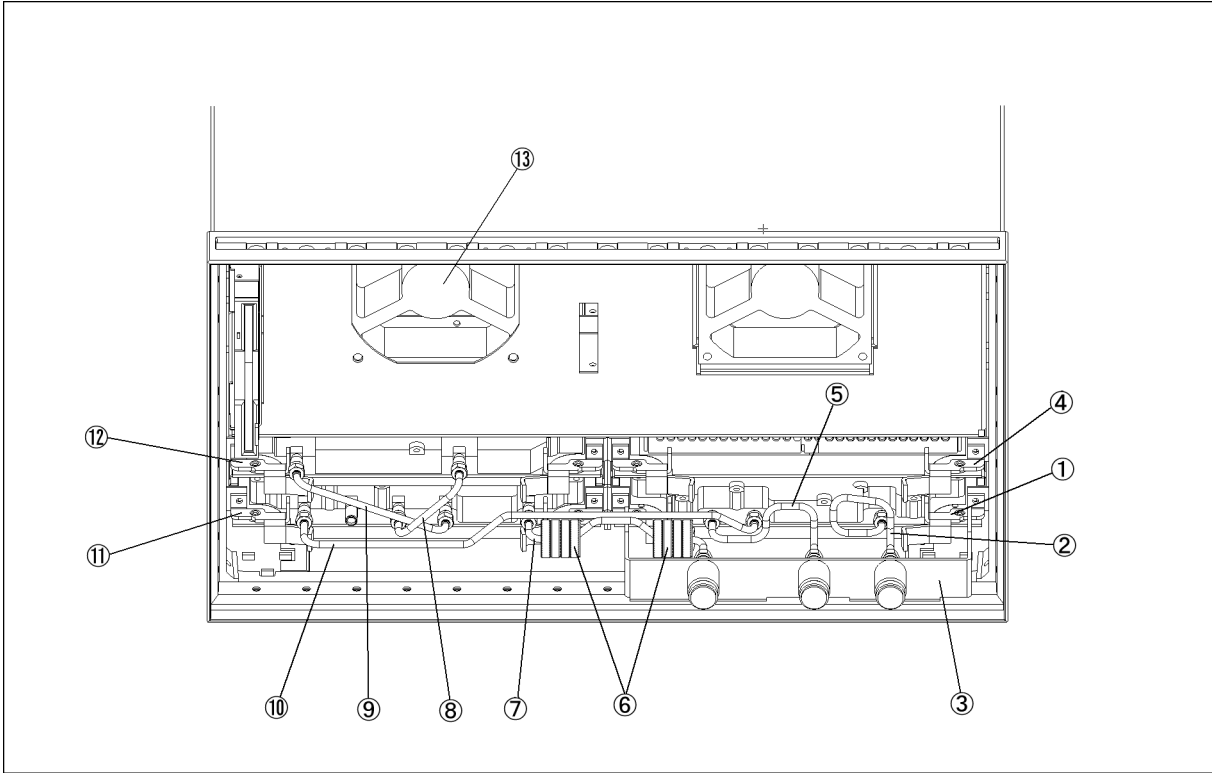
Table 6-4 Top View (Under Power Supply)

Ref. Desig.	Agilent Part Number	C/D	Qty.	Description
1	1818-7321	8	2	DIMM64MB
	1400-0249	0	10	CABLE TIE
2	04287-61631	0	1	WIRE ASSY
3	E4991-66510	4	1	ANALOG MOTHER
	0515-1550	0	10	SCREW M3-L 8 P-H
4	1821-4776	8	1	CPU IC-K6
	3160-0938	6	1	FAN
	5183-4063	6	1	THERMAL CMD
	5184-4049	0	1	CLAMP
5	04287-61622	9	1	WIRE ASSY
	04287-01213	8	1	COVER
	0515-1550	0	1	SCREW M3-L 8 P-H
6	0515-0914	8	3	SCREW-MACH M3X0.5
	1400-1334	6	1	CLAMP CABLE
7	1400-1334	6	1	CLAMP CABLE

Replaceable Parts
Replaceable Parts List (for serial prefix JP1KH, JP2KH, and MY432)

Front View (Analog Boards and Semi Rigid Cables)

Figure 6-5 Front View (Analog Boards and Semi Rigid Cables)



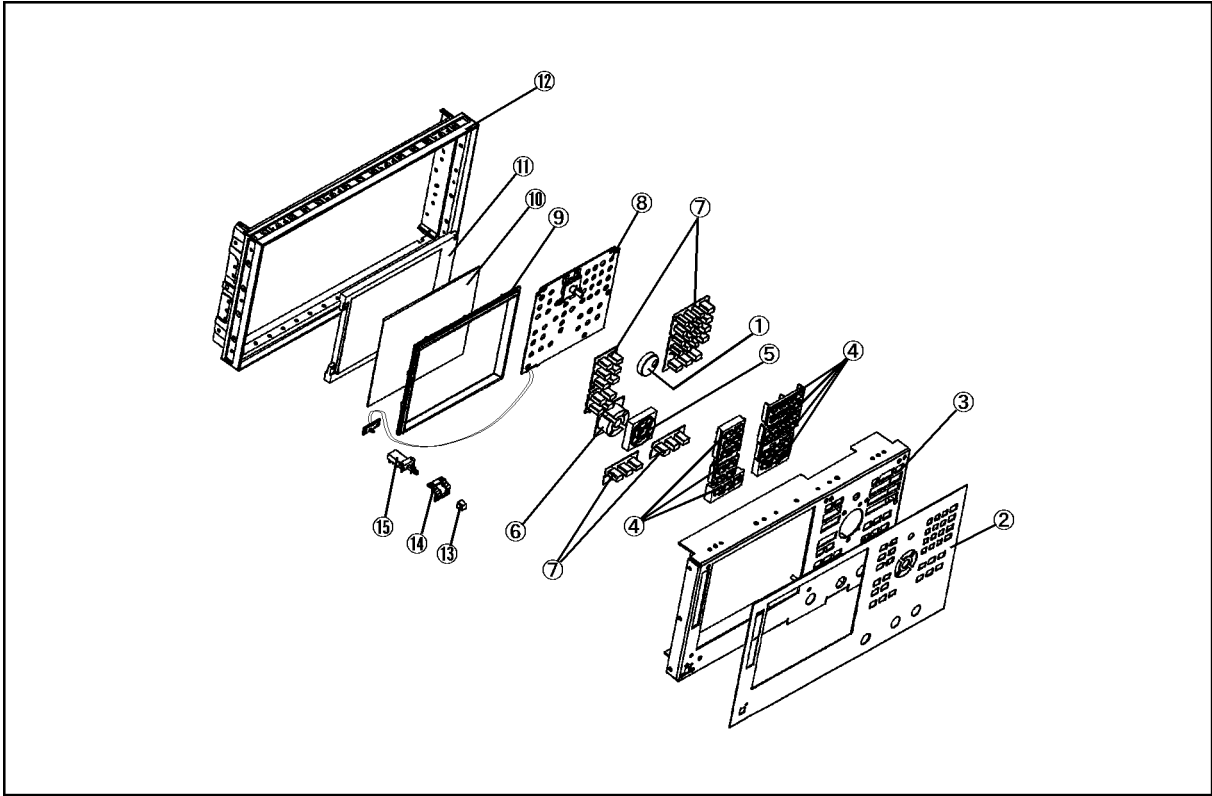
e4991ase026

Table 6-5 Front View (Analog Boards and Semi Rigid Cables)

Ref. Desig.	Agilent Part Number	C/D	Qty.	Description
1	04287-66554	6	1	A4 RECEIVER BOARD
	04287-69554	2	1	A4 RECEIVER BOARD (Exchange)
	0515-1550	0	2	SCREW M3-L 8 P-H
	0515-0924	0	4	SCREW M3X0.5
2	04287-61601	4	1	RF CABLE ASSY
3	E4991-65001	6	1	N CONNECTOR ASSY
4	E4991-66502	4	1	A2 DC BIAS BOARDS (Opt. 001)
	0515-1550	0	2	SCREW M3-L 8 P-H
5	04287-61603	6	1	RF CABLE ASSY SRGD
6	9170-1468	6	8	CORE-TROID
	1400-0249	0	2	CABLE TIE
7	04287-61604	7	1	RF CABLE ASSY
8	04287-61605	8	1	RF CABLE ASSY
9	04287-61606	9	1	RF CABLE ASSY
10	04287-61602	5	1	RF CABLE ASSY
11	E4991-66553	5	1	A3 SOURCE BOARD
	E4991-69553	1	1	SOURCE BOARD (Exchange)
	0515-1550	0	2	SCREW M3-L 8 P-H
12	04287-66511	5	1	REFERENCE OSCILLATOR
	04287-69511	1	1	REFERENCE OSCILLATOR (Exchange)
	0515-1550	0	2	SCREW M3-L 8 P-H
13	04287-61001	8	1	FAN ASSY
	0515-1666	9	4	SCREW M4X35 POZI

Front Panel

Figure 6-6 Front Panel



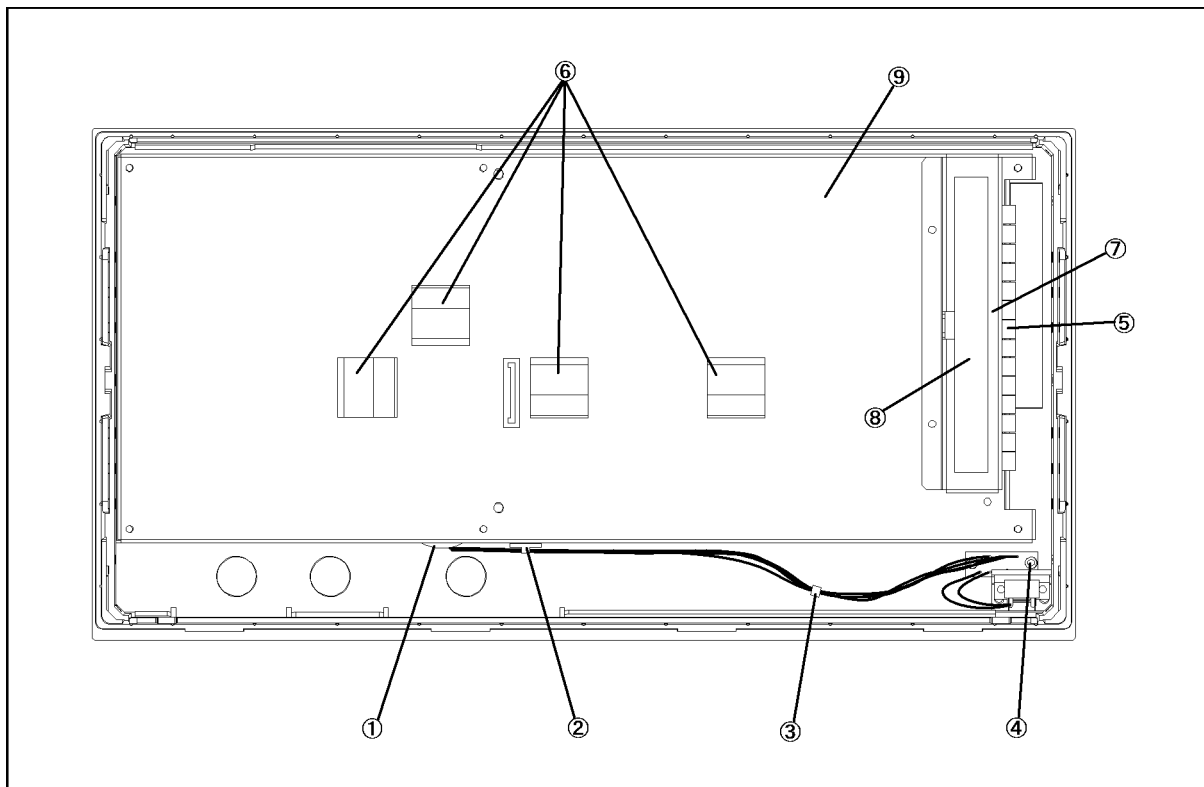
e4991ase030

Table 6-6 Front Panel

Ref. Desig.	Agilent Part Number	C/D	Qty.	Description
1	5182-7594	2	1	KNOB
2	E4991-00201	2	1	FRONT PANEL
3	E4991-00202	3	1	SUB PANEL
4	E5100-40001	9	1	FRONT BEZEL
5	04287-40004	7	1	GUIDE FOR CURSOR KEY
6	E4991-25002	3	1	RUBBER KEY (CURSOR)
7	E4991-25001	2	1	RUBBER KEY
8	E4991-66522	8	1	FRONT KEYBOARD
9	04287-40001	4	1	FRONT BEZEL
10	04287-25003	4	1	OPTICAL FILTER
11	2090-0396	0	1	LCD-DISPLAY
	04287-25004	5	1	GASKET
12	5022-1190	4	1	FRONT FRAME
13	0371-3953	5	1	KEY CAP
14	04287-01212	7	1	BRACKET SW
	0515-0999	9	2	SCREW M2.5X0.45 L=6 FL
15	04287-61901	7	1	WIRE ASSY WITH SWITCH

Front Panel (Back Side)

Figure 6-7 Front Panel (Back Side)



e4991ase028

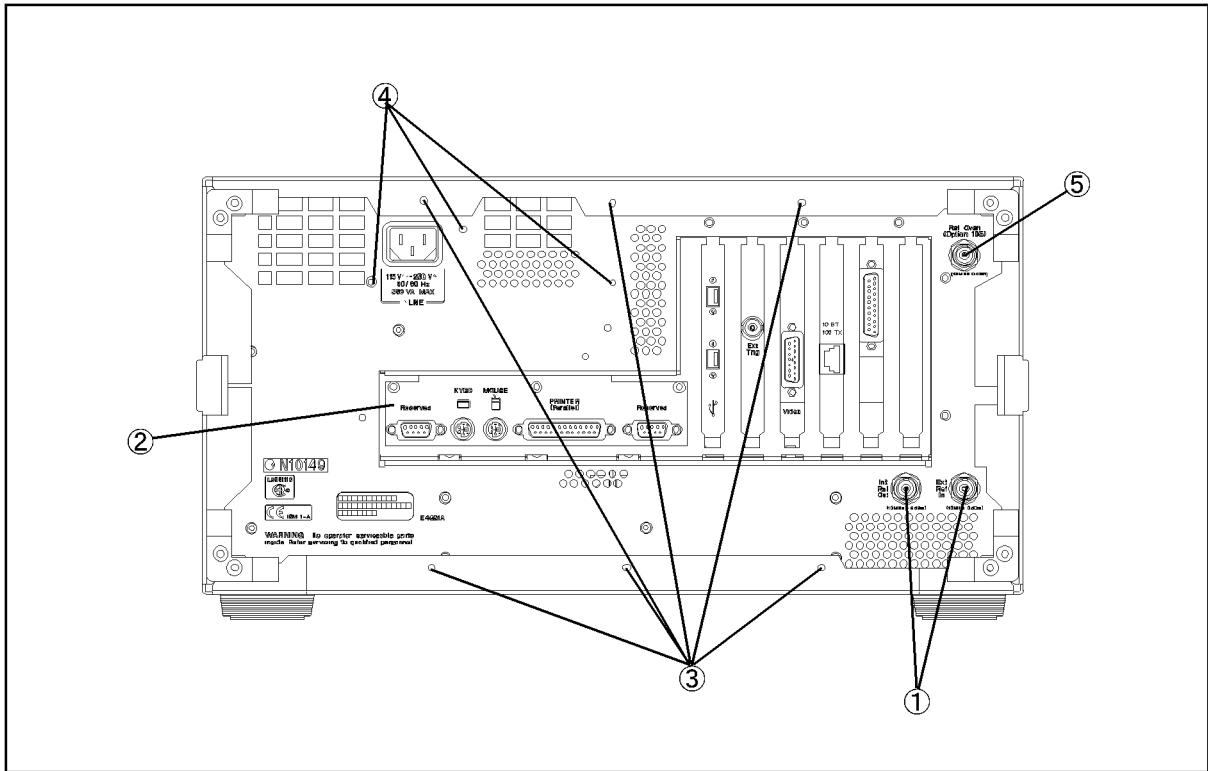
Table 6-7 Front View (Analog Boards and Semi Rigid Cables)

Ref. Desig.	Agilent Part Number	C/D	Qty.	Description
1	0400-0010	2	1	ROUND GROMET
2	1400-1334	6	1	CABLE CLAMP
3	1400-0249	0	1	CABLE TIE
4	0515-1550	0	2	SCREW M3-L 8 P-H
5	0363-0170	5	9 cm	RFI GASKET
6	1400-0611	0	4	CABLE CLAMP
7	E4991-01205	8	1	ANGLE
8	0950-2888	1	1	INVERTER BOARD
9	E4991-00606	1	1	CASE SHIELD

Rear View

Figure 6-8

Rear View



e4991ase027

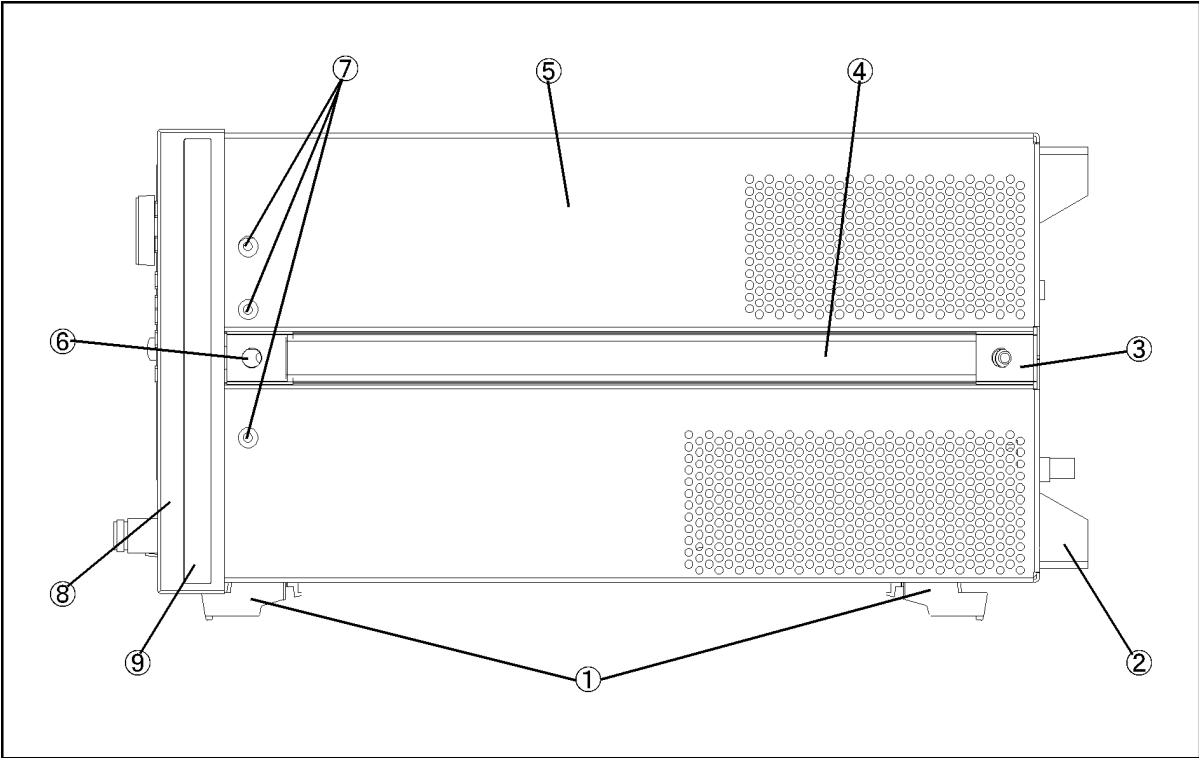
Table 6-8 Rear View

Ref. Desig.	Agilent Part Number	C/D	Qty.	Description
1	2950-0054	1	2	NUT-HEX-DBL-CHAM
	2190-0054	1	2	WSHR-LK INTL T
2	04287-01205	8	1	REAR COVER I/O
	0515-0914	8	1	SCREW-MACH M3X0.5
3	0515-1232	5	6	SCREW-MACH M3.5
4	0515-1550	0	3	SCREW M3-L 8 P-H
5	1250-0252	6	1	CONN-RF BNC (Opt. 1D5)
	2190-0102	8	1	WSHR-LK INTL T
	2950-0035	8	1	NUT-HEX-DBL-CHAM

Replaceable Parts
Replaceable Parts List (for serial prefix JP1KH, JP2KH, and MY432)

Side View

Figure 6-9 Side View



4287ase06008

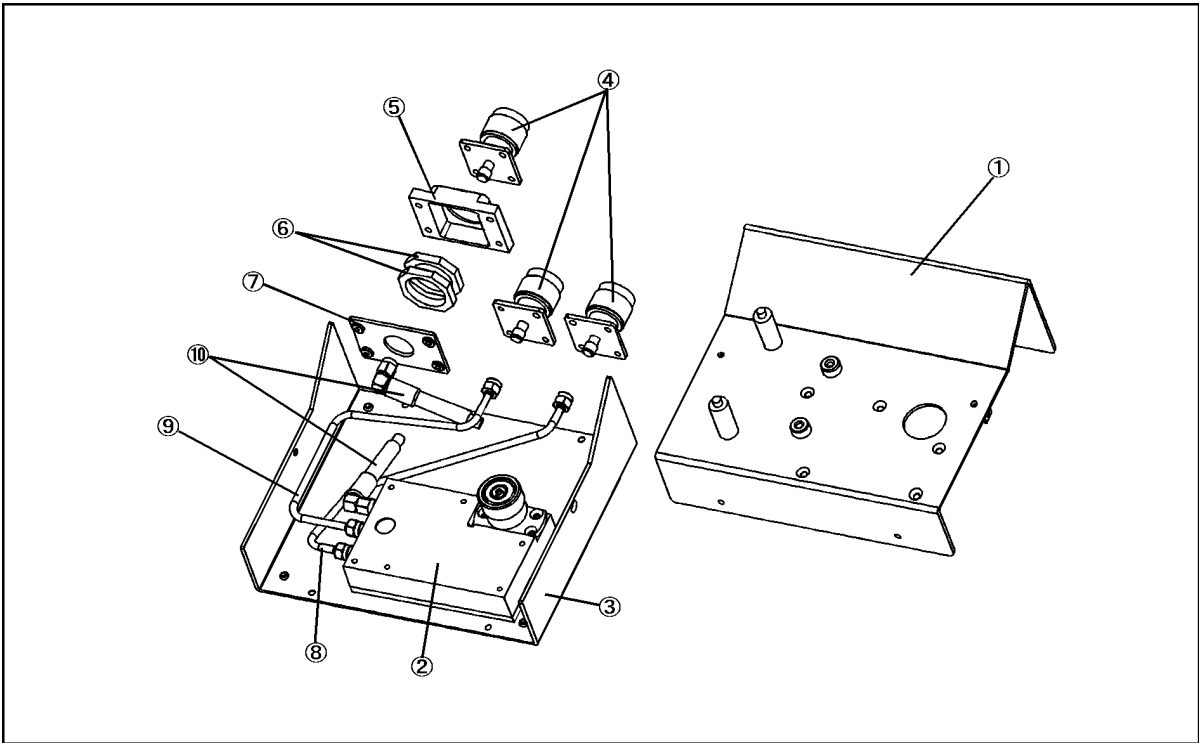
Table 6-9 Side View

Ref. Desig.	Agilent Part Number	C/D	Qty.	Description
1	5041-9167	1	4	FOOT FL
	1460-1345	5	2	WIREFORM
2	E5100-40002	0	4	STANDOFF
	0515-1232	5	4	SCREW-MACH M3.5
3	5041-9187	5	2	STRAP HANDL REAR
	0515-0956	8	2	SCREW
4	5063-9209	8	2	STRAP HANDLE
5	E4991-60002	7	1	COVER ASSY
6	5041-9186	4	2	STRAP HANDLE FRT
	0515-0956	8	2	SCREW
7	0515-2079	0	6	SCREW M4X8
8	5022-1190	4	1	FRONT FRAME221.5
	8160-0641	3	210 cm	GASKET BRAID
9	5041-9173	9	2	SIDE TRIM 221.5

Replaceable Parts
Replaceable Parts List (for serial prefix JP1KH, JP2KH, and MY432)

Test Head

Figure 6-10 Test Head



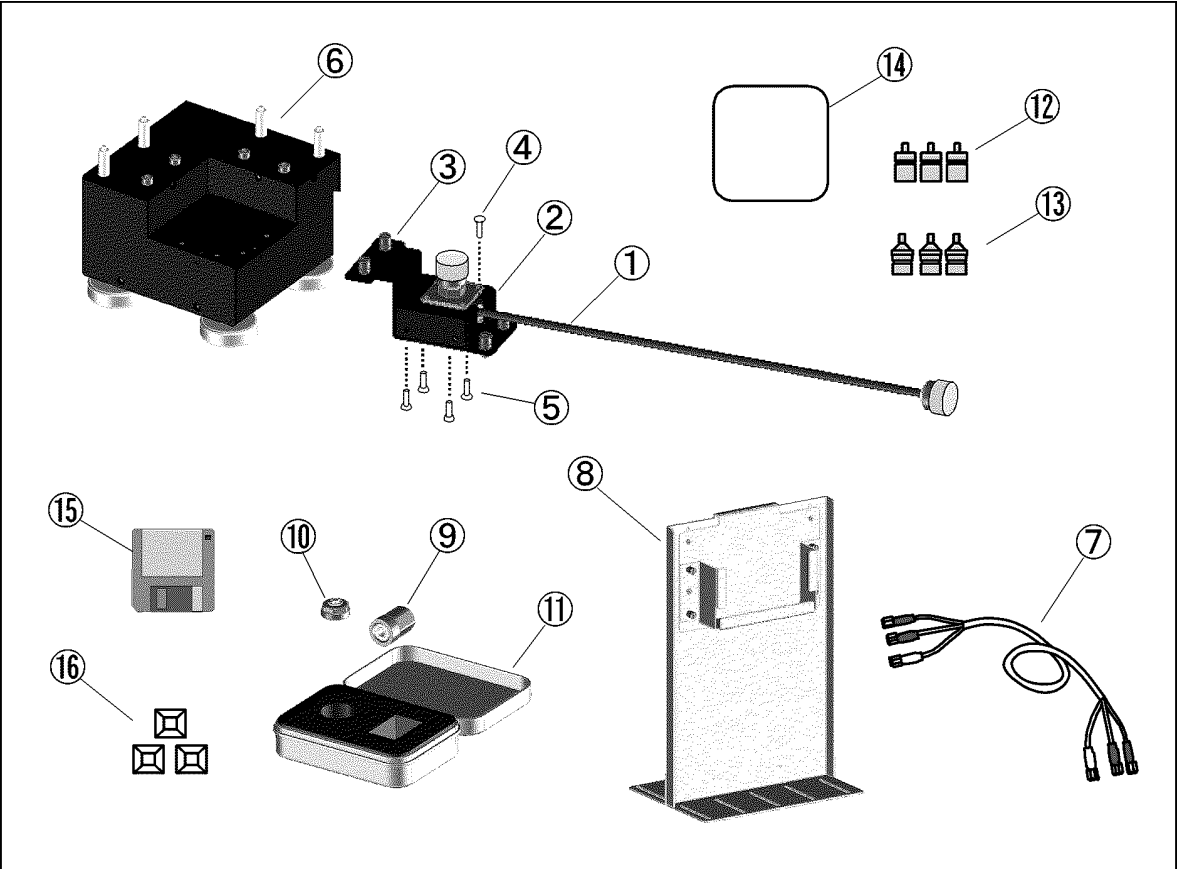
e4991ase029

Table 6-10 Test Head

Ref. Desig.	Agilent Part Number	C/D	Qty.	Description
1	E4991-04001	8	1	COVER TOP
2	E4991-60111	9	1	TEST HEAD
	0515-0914	8	5	SCREW-MACH M3X0.5
3	E4991-04002	9	1	COVER BOTTOM
	0515-0914	8	6	SCREW-MACH M3X0.5
	0403-0800	4	4	FOOT
4	1250-2468	0	3	RF CONNECTOR N-SMA
	0515-0914	9	8	SCREW-MACH M3X0.5
5	E4991-20063	6	1	HOUSING
	0515-1006	1	4	SCREW-MACH M3X0.5
6	E4991-25101	3	2	CUSHION
7	E4991-00601	6	1	PLATE
8	E4991-61601	4	1	RF CABLE ASSY
9	E4991-61602	5	1	RF CABLE ASSY
10	E4991-61603	6	1	RF CABLE ASSY

Option 007 Temperature Characteristic Test Kit

Figure 6-11 Replaceable Parts of the Option 007 Test Kit



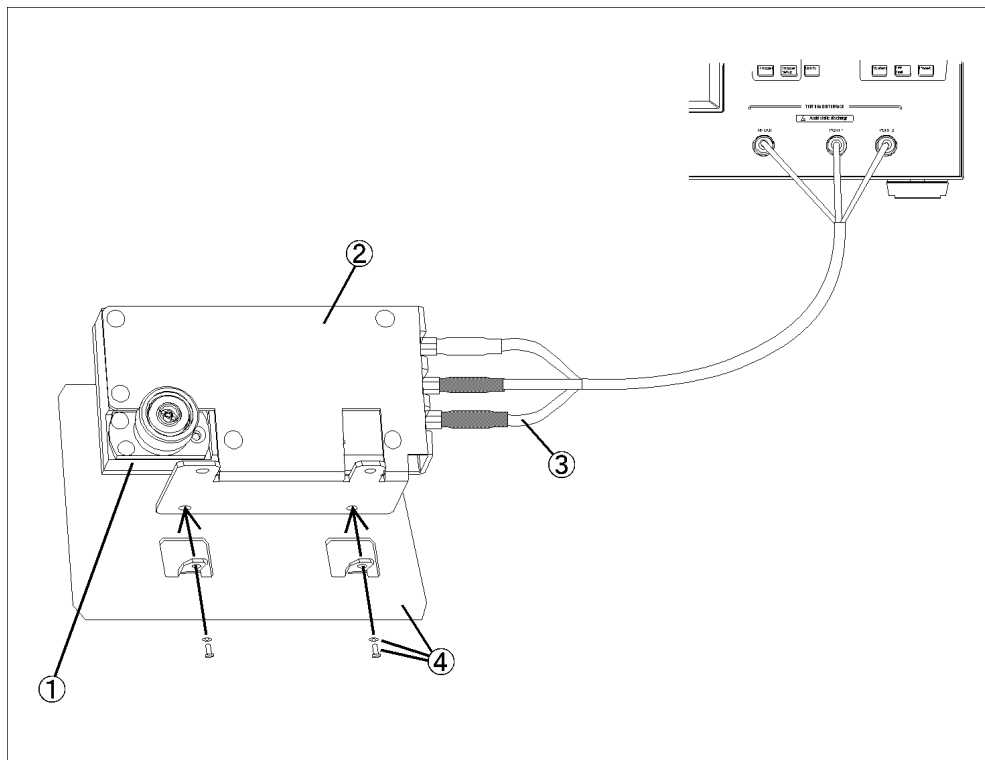
e4991u_opt00703

Table 6-11 Replaceable Pats of the Option 007

Ref. Desig.	Agilent Part Number	C/D	Qty.	Description
1	E4991-61610	5	1	CABLE ASSY HEAT-RESISTANT
2	E4991-01220	7	1	HOLDER CABLE
3	E4991-01221	8	1	HOLDER CABLE
4	0515-0372	2	4	SCREW-MACH M3X8 TORX T10 PAN
5	0515-1946	8	4	SCREW-MACH M3X6 TORX T10 90 DEG FLAT
6	E4991-60005	0	1	STAND TEST-FIXTURE
7	04287-61651	4	1	RF CABLE ASSY EXTENSION
8	E4991-60006	1	1	STAND TEST-HEAD
9	E4991-60032	3	1	TERMINATION OPEN
10	E4991-60031	2	1	TERMINATION SHORT
11	E4991-60060	7	1	CASE TEMPERATURE-COMPENSATION-SET
12	1250-2879	7	3	ADAPTER N (M) - SMA (F)
13	1250-3157	6	3	ADAPTER N (F) - SMA (F)
14	04291-09001	4	1	PAD
15	E4991-18001	7	1	DISK FLOPPY TEMP-CHARAC-TEST SOFTWARE
16	1400-0584	6	3	TIE CABLE

Test Head for Option 010

Figure 6-12 Test Head for Option 010



e4991ase133

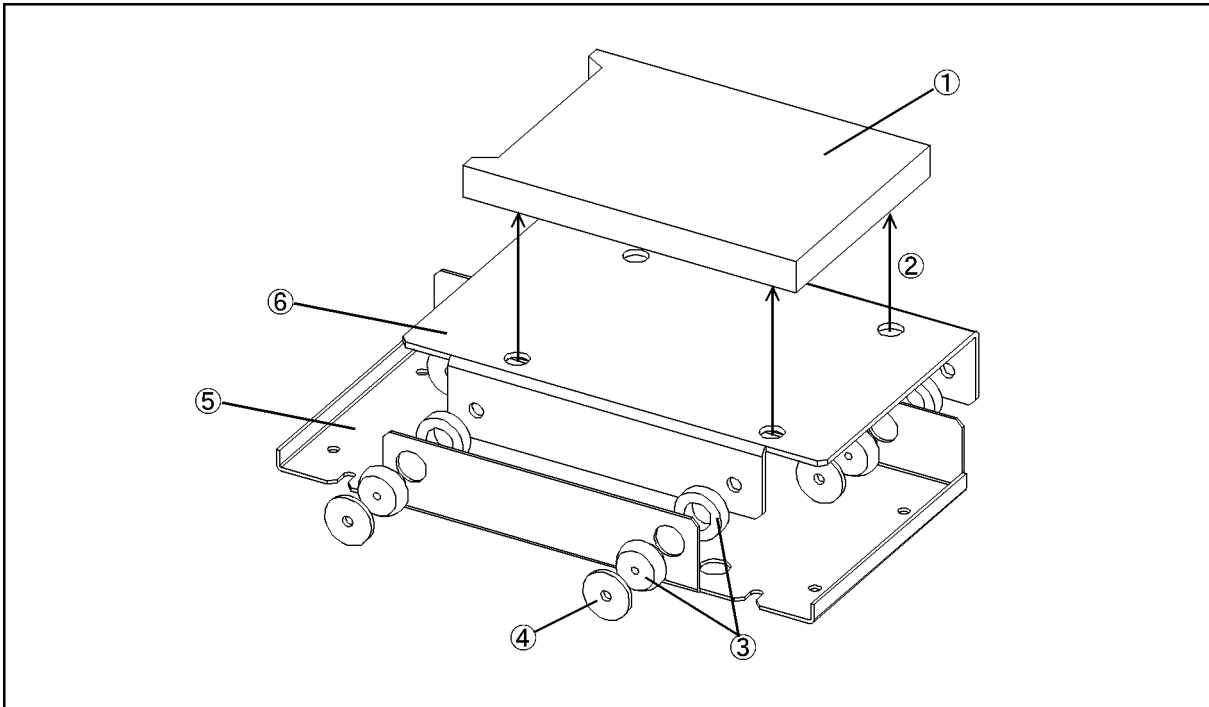
Table 6-12 Test Head for Option 010

Ref. Desig.	Agilent Part Number	C/D	Qty.	Description
1	E4991-60111	9	1	TEST HEAD
2	E4991-01210	5	1	ANGLE
3	04287-61651	4	1	EXTENSION CABLE ASSY
4	E4991-65002*1	3	1	TEST HEAD STAND FOR OPT.010

*1. for service use. Not furnished in option 010.

Mass Storage Disk Drive Assembly

Figure 6-13 **Mass Storage Disk Drive Assembly**



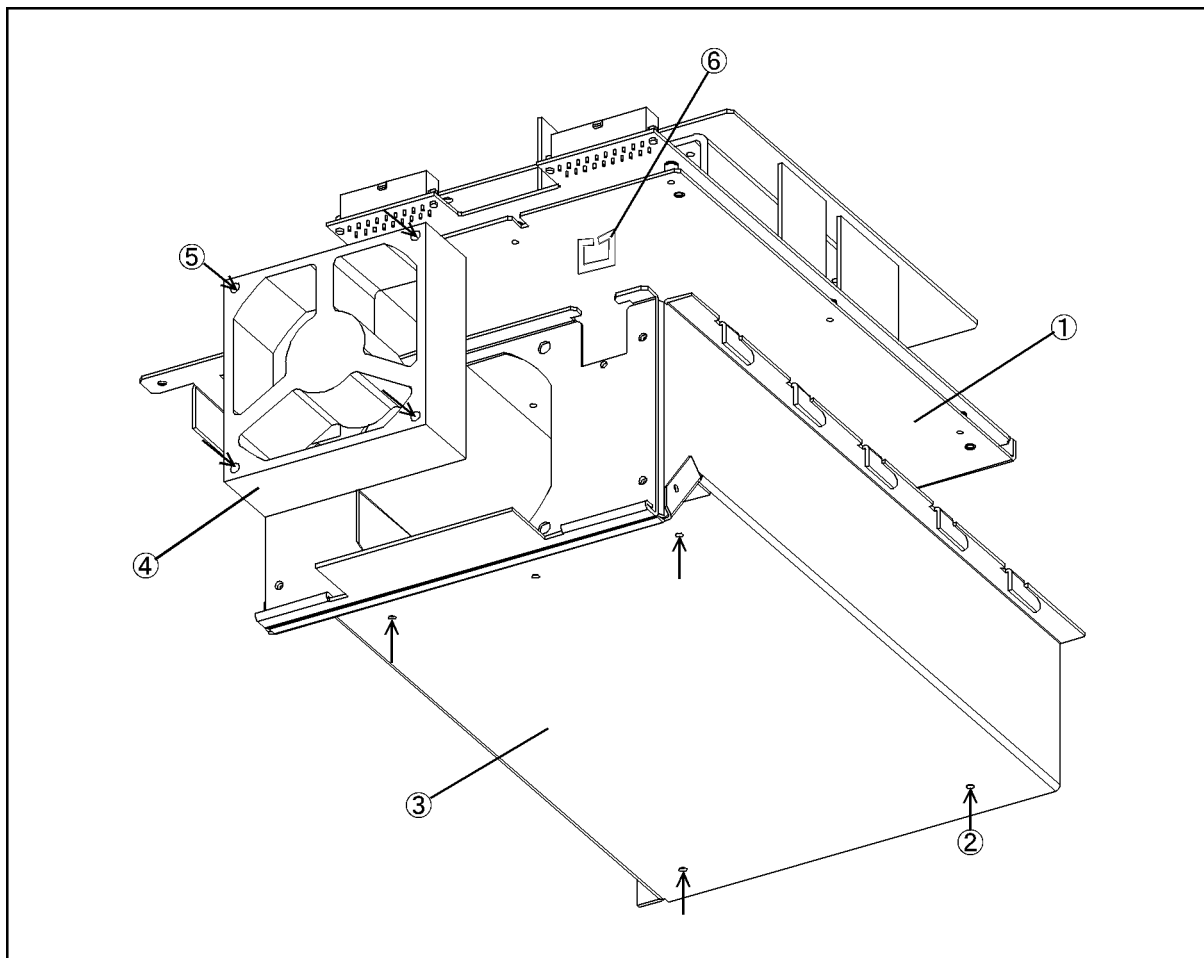
4287ase06013

Table 6-13 **Mass Storage Disk Drive Assembly**

Ref. Desig.	Agilent Part Number	C/D	Qty.	Description
1	E4991-65003	8	1	HDD INSTALLED
2	0515-0924	0	4	SCREW-MACH M3X0.5
3	1410-1580	5	4	BUSHING
4	E5010-00655	6	4	PLATE
5	04287-01211	6	1	HDD BRACKET
6	04287-01204	7	1	HDD HOLDER

Power Supply Assembly

Figure 6-14 Power Supply Assembly



4287ase06012

Table 6-14 Power Supply Assembly

Ref. Desig.	Agilent Part Number	C/D	Qty.	Description
1	0950-3396	8	1	PWR-SPLY-225W
2	0515-0924	0	2	SCREW-MACH M3X0.5
3	04287-60003	8	1	BRACKET P/S ASSY
4	04287-61001	8	1	FAN ASSY
5	0515-1666	9	4	SCREW M4X35 POZI
6	1400-2198	2	2	SADDLE-EDGE

Other Parts

Table 6-15 Other Parts

Agilent Part Number	C/D	Qty.	Description
E4991-900x0	4	1	OPERATION MANUAL
E4991-900x2	6	1	PROGRAMMING MANUAL
E4991-901x0	9	1	SERVICE MANUAL *1
E4991-180x0	0	1	SAMPLE PROGRAM SET
E4991-900x1	5	1	QUICK START GUIDE
E4991-905x0	9	1	CD-ROM (manual)
E4991-16000	2	1	RECOVERY FD 1.00
E4991-16101	4	1	CD-ROM SOFTWARE 1.00
1150-7846	6	1	MOUSE PS/2
1150-7970	7	1	KEYBOARD
8710-1766	2	1	TORQUE WRENCH
E4991-60021	0	1	SHORT TERMINATION *2
E4991-60022	1	1	OPEN TERMINATION *2
04287-60021	0	1	50 OHM TERMINATION *2
04287-60022	1	1	LOW-LOSS CAPACITOR *2
16195-60041	8	1	CARRYING CASE *2
16195-90030	8	1	OPERATION NOTE, 16195B *2

*1. Opt. 0BW only

*2. Included in 16195B Calibration Kit

Replaceable Parts List (for serial prefix MY433 and later)

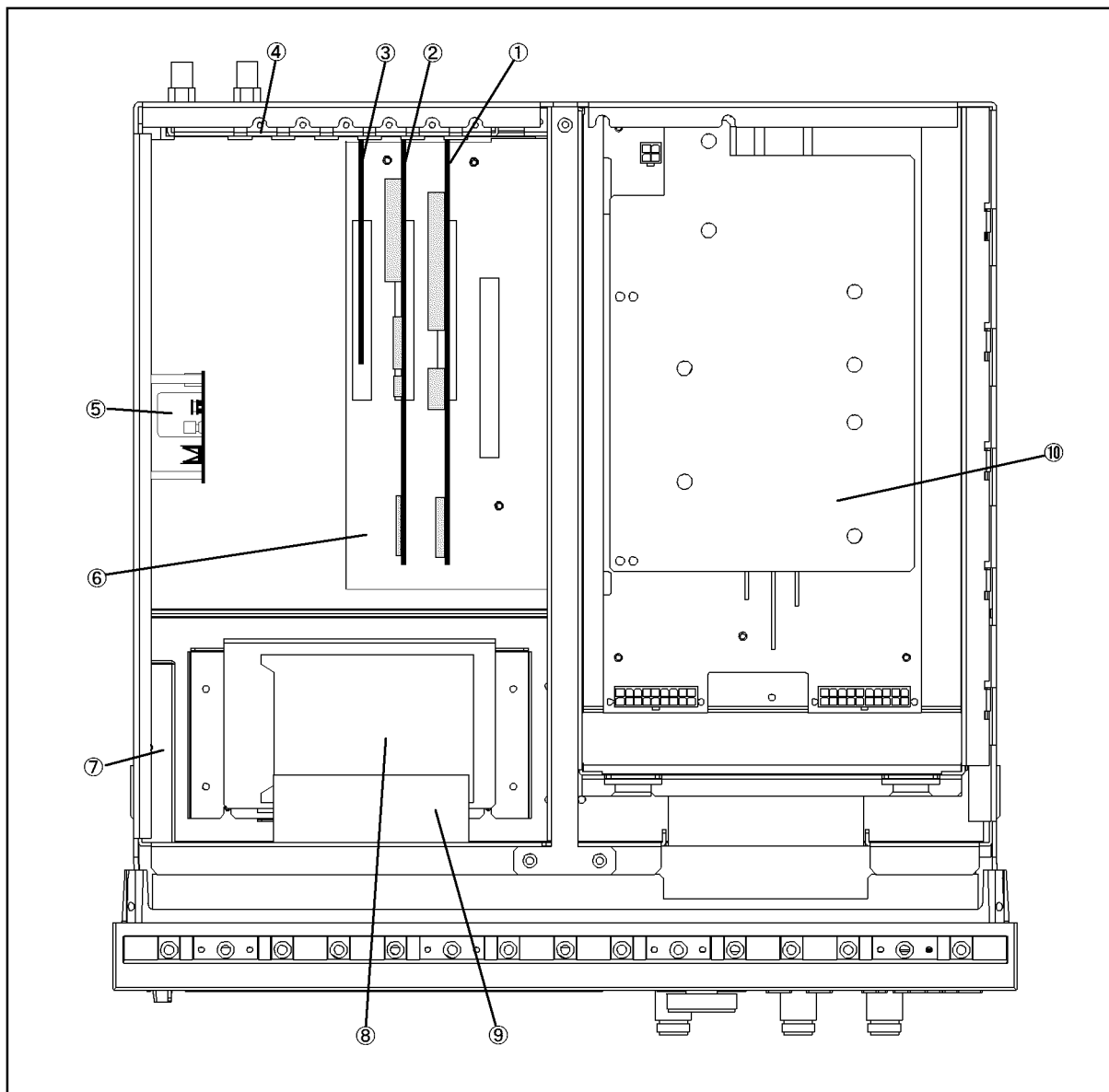
Power Cables and Plug Configurations

For details of the power cables and plug configurations, refer to Appendix D, “Power Requirement,” on page 331.

Top View (Major Assembly)

Figure 6-15

Top View (Major Assembly)



e4991ase091

Table 6-16 Top View (Major Assembly)

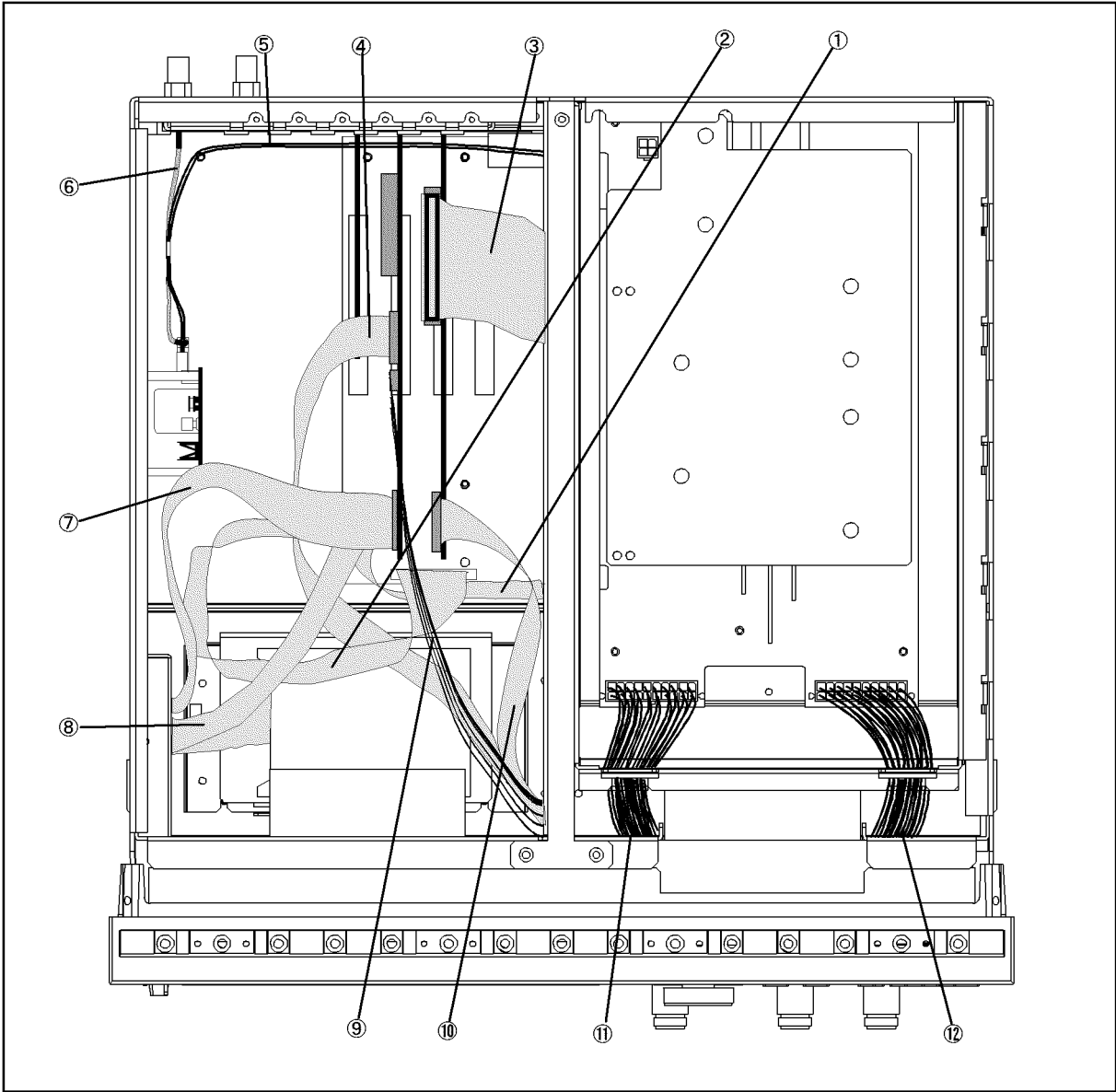
Ref. Desig.	Agilent Part Number	C/D	Qty.	Description
1	04287-66531		1	A21 ANALOG INTERFACE BOARD
	1818-6491	1	1	IC, EEPROM*1
	0515-0430	3	1	SCREW M3
2	54810-66413	6	1	A26 DISPLAY BOARD
	04287-87101	3	1	LABEL
	0515-0430	3	1	SCREW M3
3	E5070-61007	8	1	A24 GPIB BOARD
	0515-0430	3	1	SCREW M3
4	04287-01210	5	3	SLOT COVER
	0515-0430	3	3	SCREW M3
5	E4991-66505	7	1	A5 10MHz OVEN Assemble (Opt. 1D5)
	0515-0914	8	3	SCREW-MACH M3X0.5
6	0960-2372	1	1	A20 ATX DIGITAL MOTHER BOARD
	0515-1250	7	5	SCREW M3X0.5
7	See Table 6-28		1	A28 Floppy Disk Drive Assembly
	0515-1550	0	4	SCREW M3-L 8 P-H
8	See Table 6-13		1	Mass Storage Disk Drive Assembly
	0515-1550	0	4	SCREW M3-L 8 P-H
9	04287-61001	8	1	FAN ASSY
	0515-1666	9	4	SCREW M4X35 POZI
10	See Table 6-14		1	A50 Power Supply Assembly

*1. Included in the analog Interface board.

Replaceable Parts
Replaceable Parts List (for serial prefix MY433 and later)

Top View (Cables & Other Parts)

Figure 6-16 Top View (Cables & Other Parts)



e4991ase092

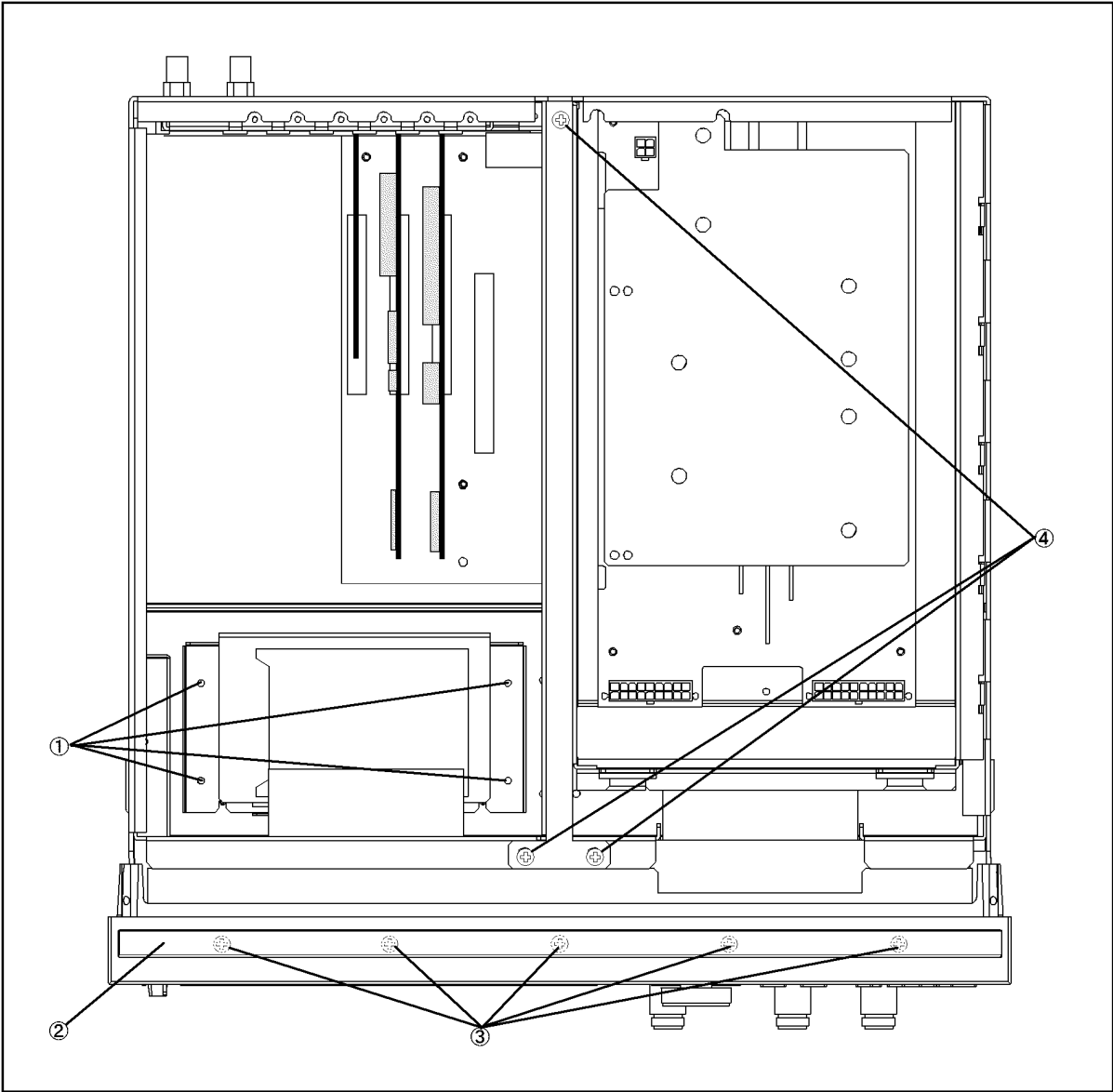
Table 6-17 Top View (Cables)

Ref. Desig.	Agilent Part Number	C/D	Qty.	Description
1	54801-61610	4	1	FLAT CABLE ASSY
2	54801-61611	5	1	FLAT CABLE ASSY
3	04396-61707	3	1	CABLE ASSY
4	04287-61607	0	1	FLAT CABLE
5	E4991-61606	9	1	WIRE ASSY
6	E4991-61605	8	1	RF CABLE ASSY
7	E5100-61661	1	1	CABLE FLAT 26PIN
8	54801-61636	4	1	FLAT CABLE ASSY
9	54801-61635	3	1	WIRE ASSY
10	04287-61609	2	1	FLAT CABLE ASSY
11	04287-61632	1	1	WIRE ASSY
12	04287-61633	2	1	WIRE ASSY

Replaceable Parts
Replaceable Parts List (for serial prefix MY433 and later)

Top View (Miscellaneous Parts)

Figure 6-17 Top View (Miscellaneous Parts)



e4991ase093

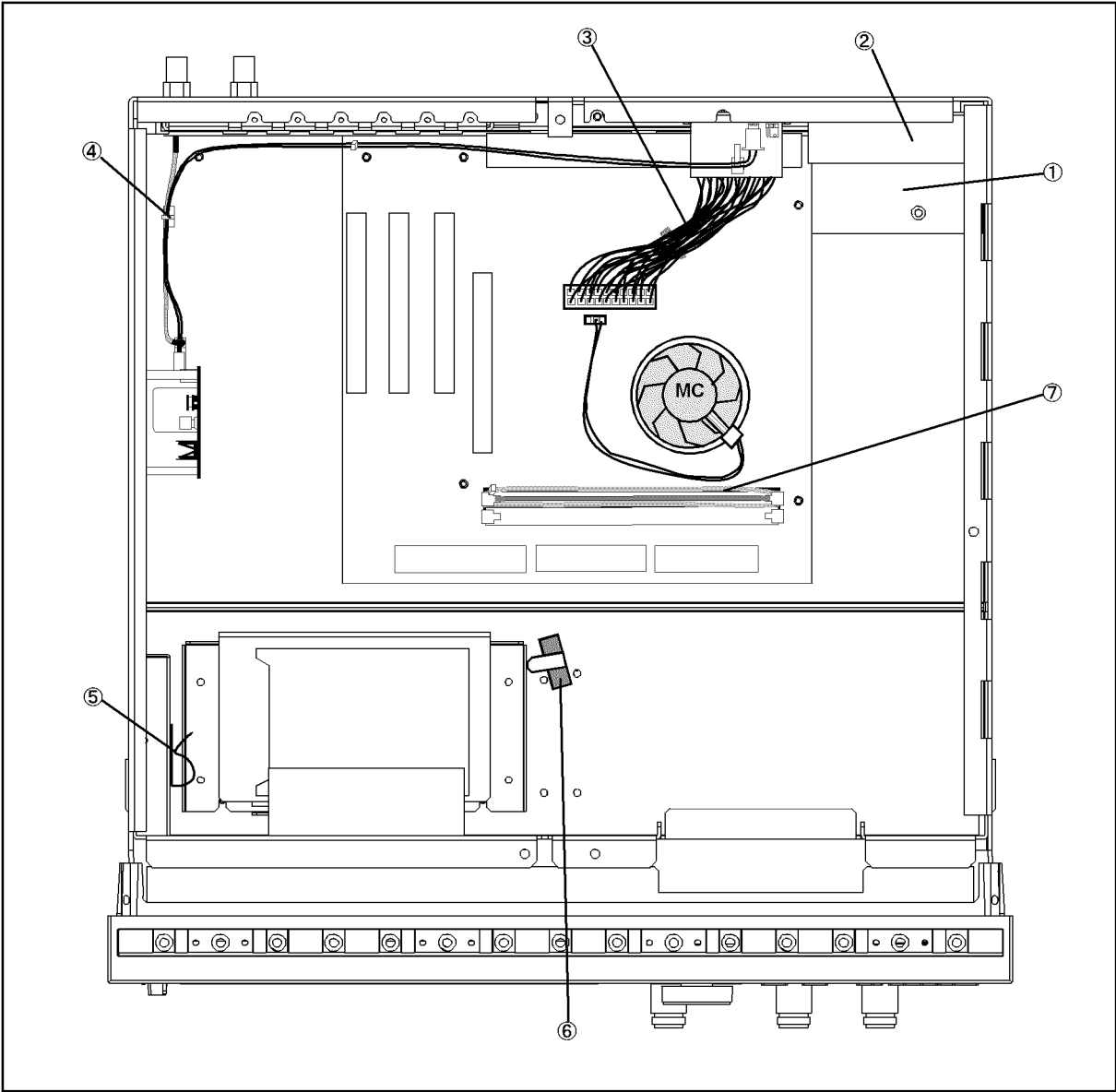
Table 6-18 Top View (Screw)

Ref. Desig.	Agilent Part Number	C/D	Qty.	Description
1	0515-1550	0	4	SCREW M3-L 8 P-H
2	5041-9176	2	1	TRIM STRIP
3	0515-0889	6	5	SCREW-MACH M3.5X.6
	0515-0889	6	6	SCREW-MACH M3.5X.6 (Bottom Side)
4	0515-0914	8	3	SCREW-MACH M3X0.5

Replaceable Parts
Replaceable Parts List (for serial prefix MY433 and later)

Top View (Under Power Supply)

Figure 6-18 Top View (Under Power Supply)



e4991ase094

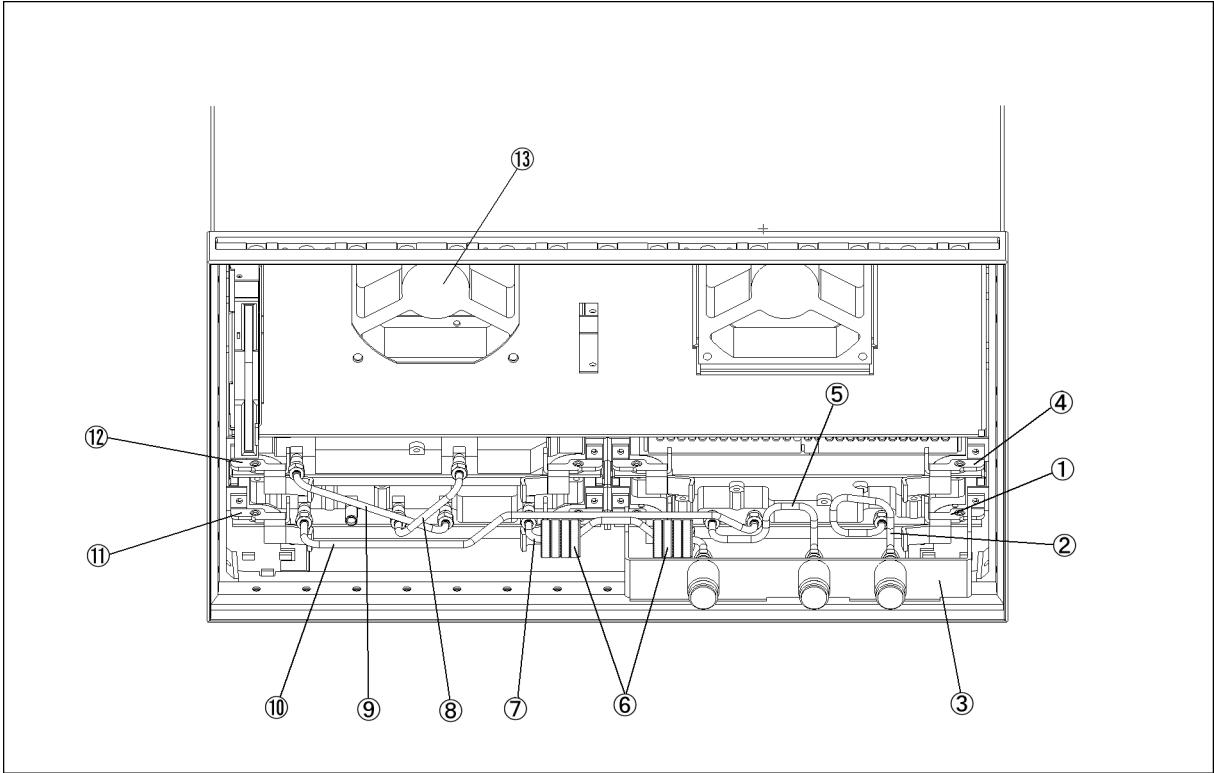
Table 6-19 Top View (Under Power Supply)

Ref. Desig.	Agilent Part Number	C/D	Qty.	Description
1	04287-01213	8	1	COVER
	0515-1550	0	1	SCREW M3-L 8 P-H
	0515-0914	8	3	SCREW-MACH M3X0.5
2	E4991-66510	4	1	ANALOG MOTHER
	0515-1550	0	10	SCREW M3-L 8 P-H
3	04287-61631	0	1	WIRE ASSY
4	1400-1334	6	1	CLAMP CABLE
5	1400-0611	0	1	CLAMP CABLE
6	1400-1334	6	1	CLAMP CABLE
7	1400-3207		1	CABLE TIE

Replaceable Parts
Replaceable Parts List (for serial prefix MY433 and later)

Front View (Analog Boards and Semi Rigid Cables)

Figure 6-19 Front View (Analog Boards and Semi Rigid Cables)



e4991ase026

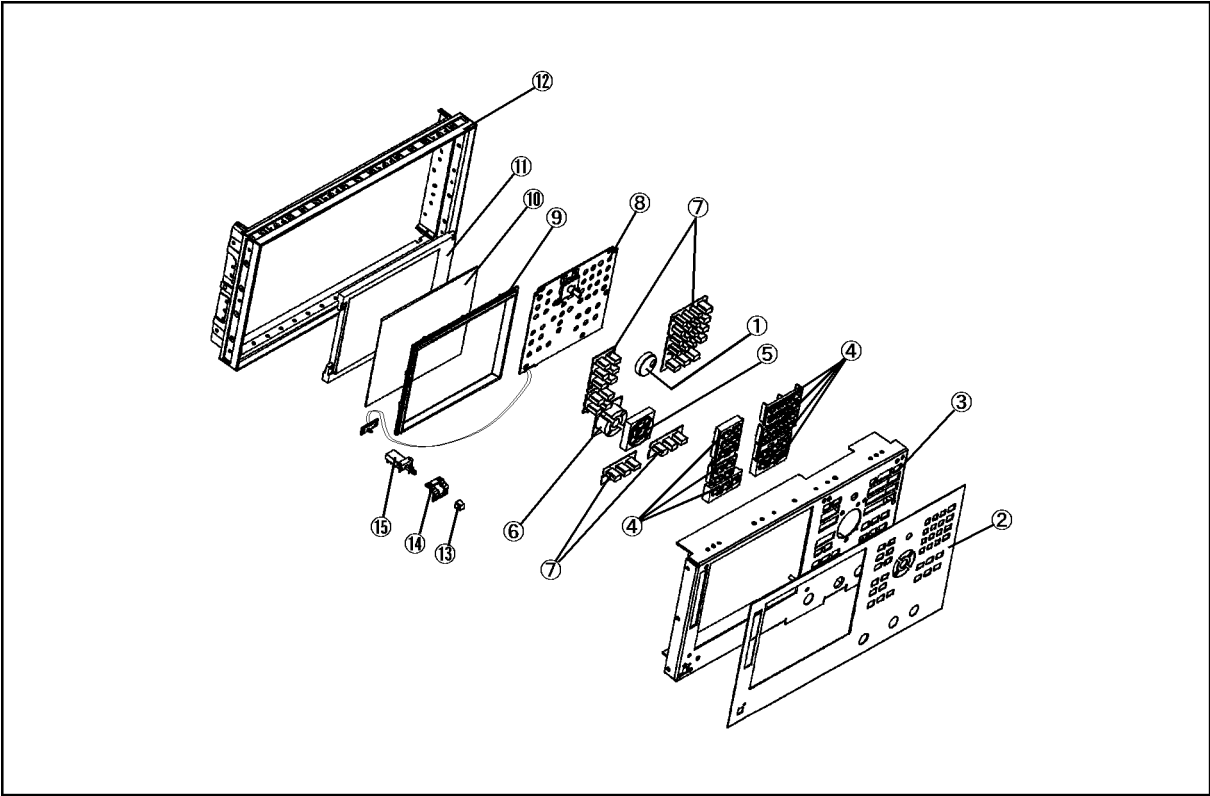
Table 6-20 Front View (Analog Boards and Semi Rigid Cables)

Ref. Desig.	Agilent Part Number	C/D	Qty.	Description
1	04287-66554	6	1	A4 RECEIVER BOARD
	04287-69554	2	1	A4 RECEIVER BOARD (Exchange)
	0515-1550	0	2	SCREW M3-L 8 P-H
	0515-0924	0	4	SCREW M3X0.5
2	04287-61601	4	1	RF CABLE ASSY
3	E4991-65001	6	1	N CONNECTOR ASSY
4	E4991-66502	4	1	A2 DC BIAS BOARDS (Opt. 001)
	0515-1550	0	2	SCREW M3-L 8 P-H
5	04287-61603	6	1	RF CABLE ASSY SRGD
6	9170-1468	6	8	CORE-TROID
	1400-0249	0	2	CABLE TIE
8	04287-61605	8	1	RF CABLE ASSY
9	04287-61606	9	1	RF CABLE ASSY
10	04287-61602	5	1	RF CABLE ASSY
11	E4991-66553	5	1	A3 SOURCE BOARD
	E4991-69553	1	1	SOURCE BOARD (Exchange)
	0515-1550	0	2	SCREW M3-L 8 P-H
12	04287-66511	5	1	REFERENCE OSCILLATOR
	04287-69511	1	1	REFERENCE OSCILLATOR (Exchange)
	0515-1550	0	2	SCREW M3-L 8 P-H
13	04287-61001	8	1	FAN ASSY
	0515-1666	9	4	SCREW M4X35 POZI

Replaceable Parts
Replaceable Parts List (for serial prefix MY433 and later)

Front Panel

Figure 6-20 Front Panel



e4991ase030

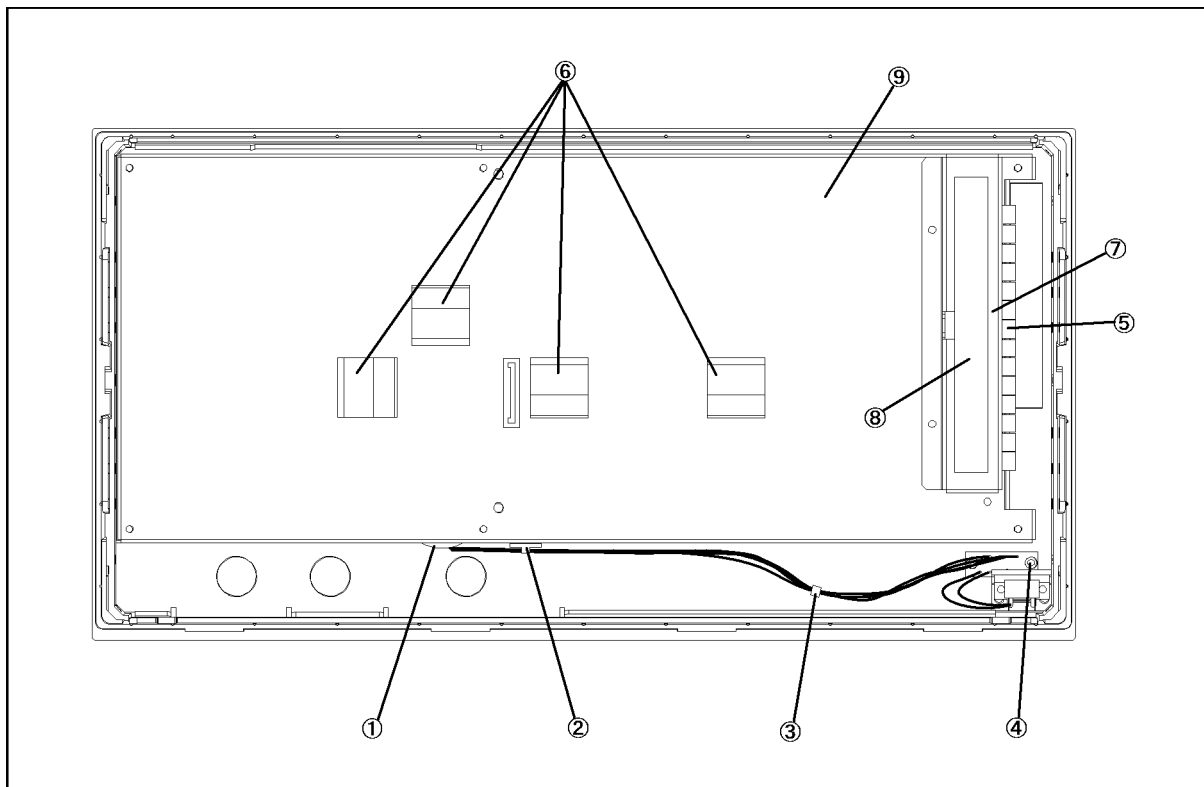
Table 6-21 Front Panel

Ref. Desig.	Agilent Part Number	C/D	Qty.	Description
1	5182-7594	2	1	KNOB
2	E4991-00201	2	1	FRONT PANEL
3	E4991-00202	3	1	SUB PANEL
4	E5100-40001	9	1	FRONT BEZEL
5	04287-40004	7	1	GUIDE FOR CURSOR KEY
6	E4991-25002	3	1	RUBBER KEY (CURSOR)
7	E4991-25001	2	1	RUBBER KEY
8	E4991-66522	8	1	FRONT KEYBOARD
9	04287-40001	4	1	FRONT BEZEL
10	04287-25003	4	1	OPTICAL FILTER
11	2090-0396	0	1	LCD-DISPLAY
	04287-25004	5	1	GASKET
12	5022-1190	4	1	FRONT FRAME
13	0371-3953	5	1	KEY CAP
14	04287-01212	7	1	BRACKET SW
	0515-0999	9	2	SCREW M2.5X0.45 L=6 FL
15	04287-61901	7	1	WIRE ASSY WITH SWITCH

Replaceable Parts
 Replaceable Parts List (for serial prefix MY433 and later)

Front Panel (Back Side)

Figure 6-21 Front Panel (Back Side)



e4991ase028

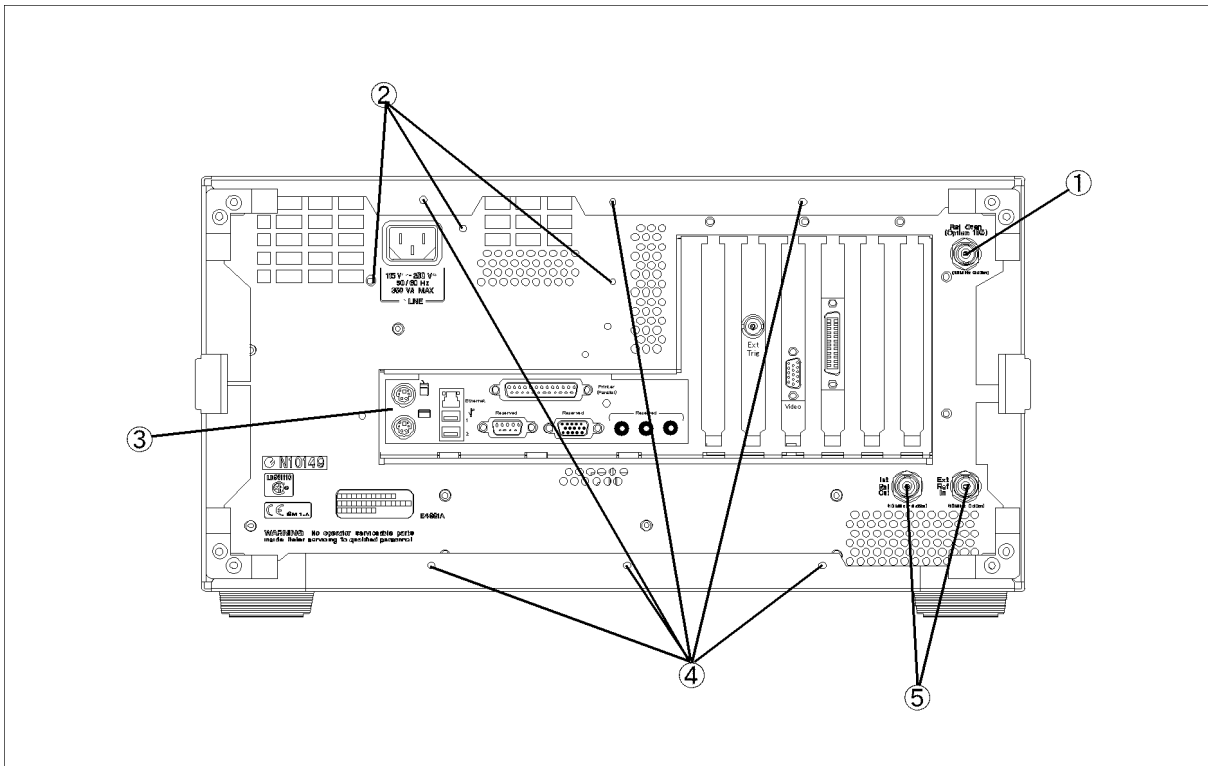
Table 6-22 Front View (Analog Boards and Semi Rigid Cables)

Ref. Desig.	Agilent Part Number	C/D	Qty.	Description
1	0400-0010	2	1	ROUND GROMET
2	1400-1334	6	1	CABLE CLAMP
3	1400-0249	0	1	CABLE TIE
4	0515-1550	0	2	SCREW M3-L 8 P-H
5	0363-0170	5	9 cm	RFI GASKET
6	1400-0611	0	4	CABLE CLAMP
7	E4991-01205	8	1	ANGLE
8	0950-2888	1	1	INVERTER BOARD
9	E4991-00606	1	1	CASE SHIELD

Rear View

Figure 6-22

Rear View



e4991ase095

Table 6-23

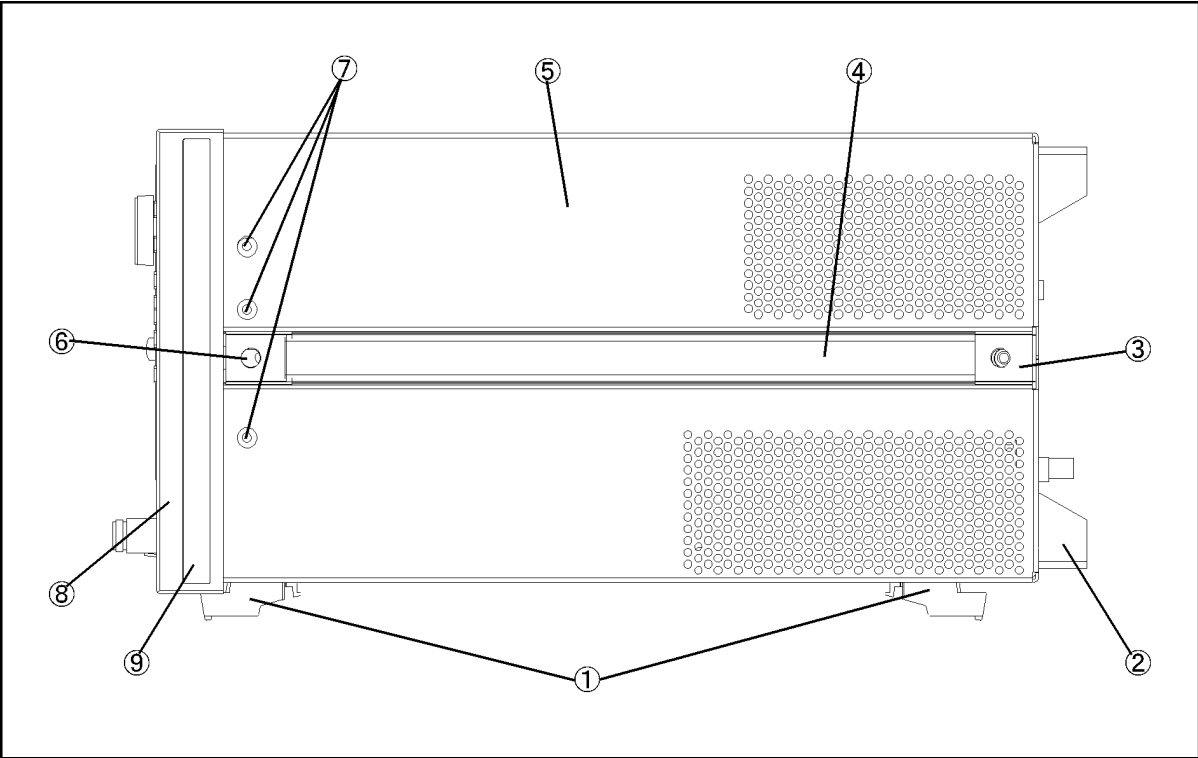
Rear View

Ref. Desig.	Agilent Part Number	C/D	Qty.	Description
1	1250-0252	6	1	CONN-RF BNC (Opt. 1D5)
	2190-0102	8	1	WSHR-LK INTL T
	2950-0035	8	1	NUT-HEX-DBL-CHAM
2	0515-1550	0	3	SCREW M3-L 8 P-H
	04287-01270		1	REAR COVER I/O
3	0515-0914	8	2	SCREW-MACH M3X0.5
	0515-1232	5	6	SCREW-MACH M3.5
4	2950-0054	1	2	NUT-HEX-DBL-CHAM
	2190-0054	1	2	WSHR-LK INTL T

Replaceable Parts
Replaceable Parts List (for serial prefix MY433 and later)

Side View

Figure 6-23 Side View



4287ase06008

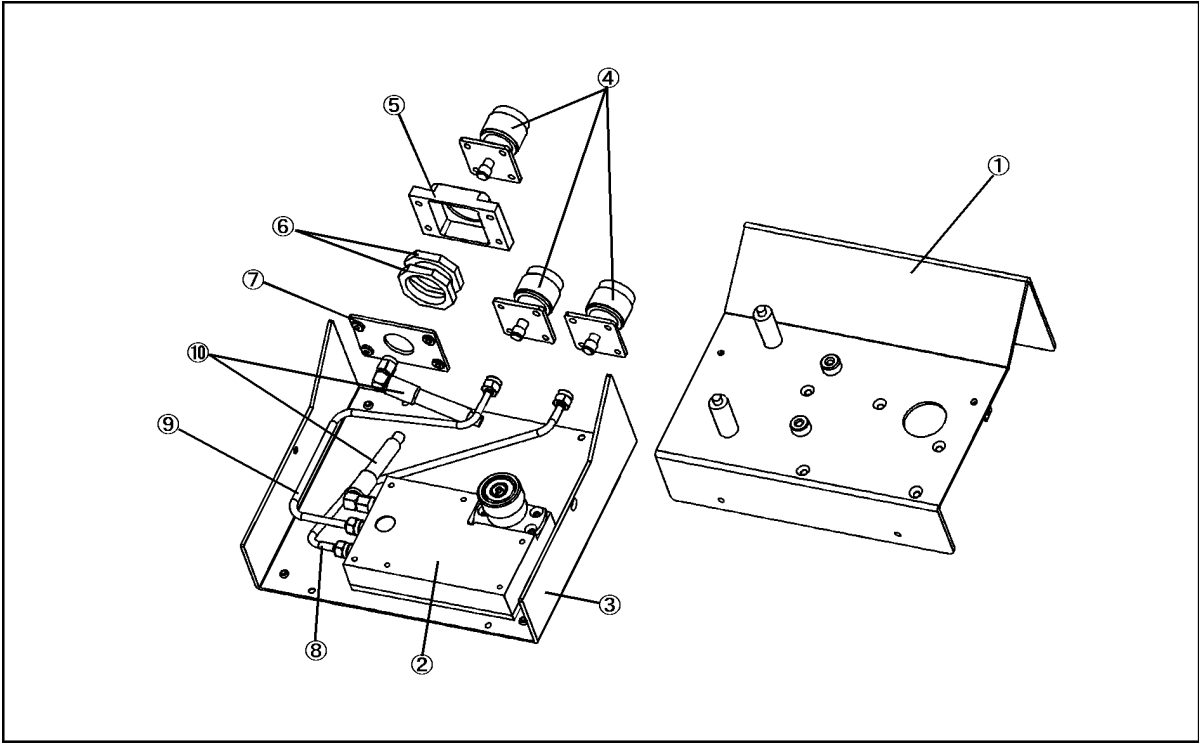
Table 6-24 Side View

Ref. Desig.	Agilent Part Number	C/D	Qty.	Description
1	5041-9167	1	4	FOOT FL
	1460-1345	5	2	WIREFORM
2	E5100-40002	0	4	STANDOFF
	0515-1232	5	4	SCREW-MACH M3.5
3	5041-9187	5	2	STRAP HANDL REAR
	0515-0956	8	2	SCREW
4	5063-9209	8	2	STRAP HANDLE
5	E4991-60002	7	1	COVER ASSY
6	5041-9186	4	2	STRAP HANDLE FRT
	0515-0956	8	2	SCREW
7	0515-2079	0	6	SCREW M4X8
8	5022-1190	4	1	FRONT FRAME221.5
	8160-0641	3	210 cm	GASKET BRAID
9	5041-9173	9	2	SIDE TRIM 221.5

Replaceable Parts
Replaceable Parts List (for serial prefix MY433 and later)

Test Head

Figure 6-24 Test Head



e4991ase029

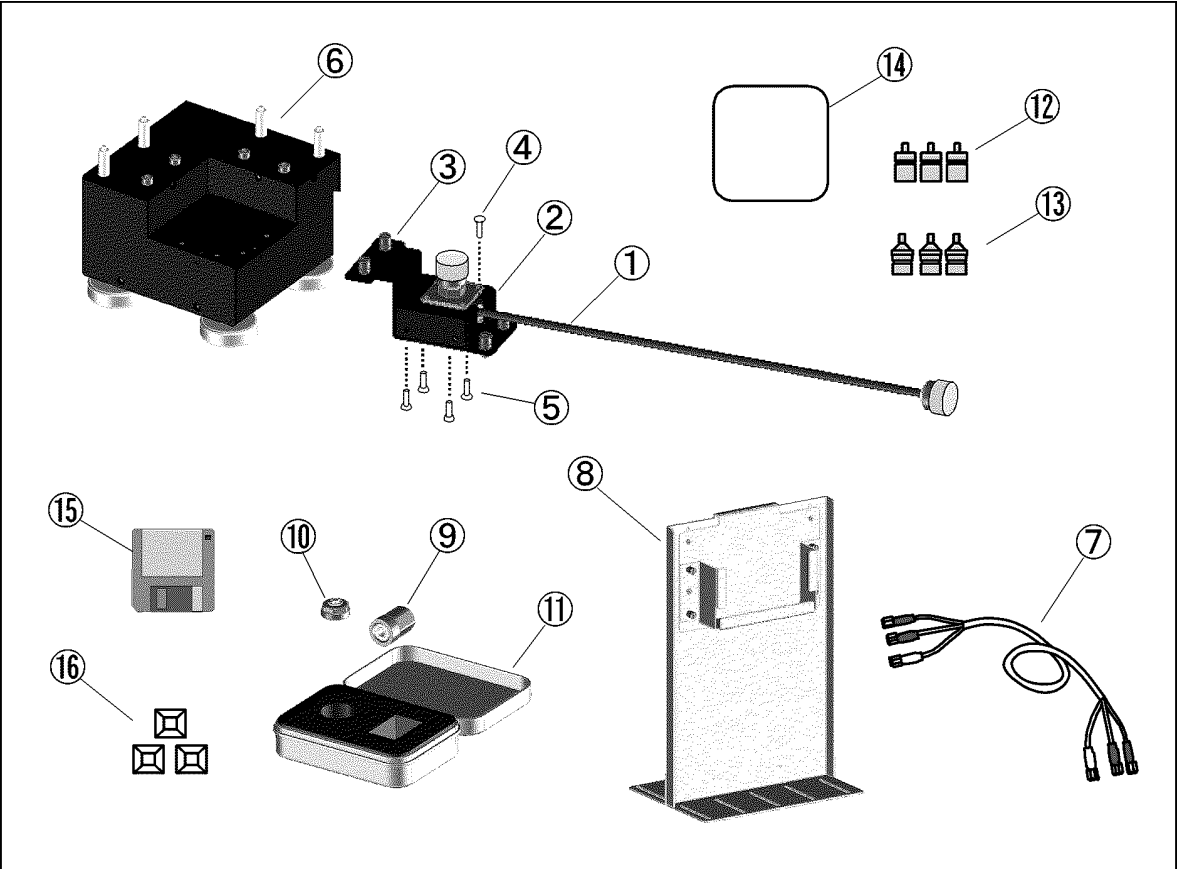
Table 6-25 Test Head

Ref. Desig.	Agilent Part Number	C/D	Qty.	Description
1	E4991-04001	8	1	COVER TOP
2	E4991-60111	9	1	TEST HEAD
	0515-0914	8	5	SCREW-MACH M3X0.5
3	E4991-04002	9	1	COVER BOTTOM
	0515-0914	8	6	SCREW-MACH M3X0.5
	0403-0800	4	4	FOOT
4	1250-2468	0	3	RF CONNECTOR N-SMA
	0515-0914	9	8	SCREW-MACH M3X0.5
5	E4991-20063	6	1	HOUSING
	0515-1006	1	4	SCREW-MACH M3X0.5
6	E4991-25101	3	2	CUSHION
7	E4991-00601	6	1	PLATE
8	E4991-61601	4	1	RF CABLE ASSY
9	E4991-61602	5	1	RF CABLE ASSY
10	E4991-61603	6	1	RF CABLE ASSY

Replaceable Parts
Replaceable Parts List (for serial prefix MY433 and later)

Option 007 Temperature Characteristic Test Kit

Figure 6-25 Replaceable Parts of the Option 007 Test Kit



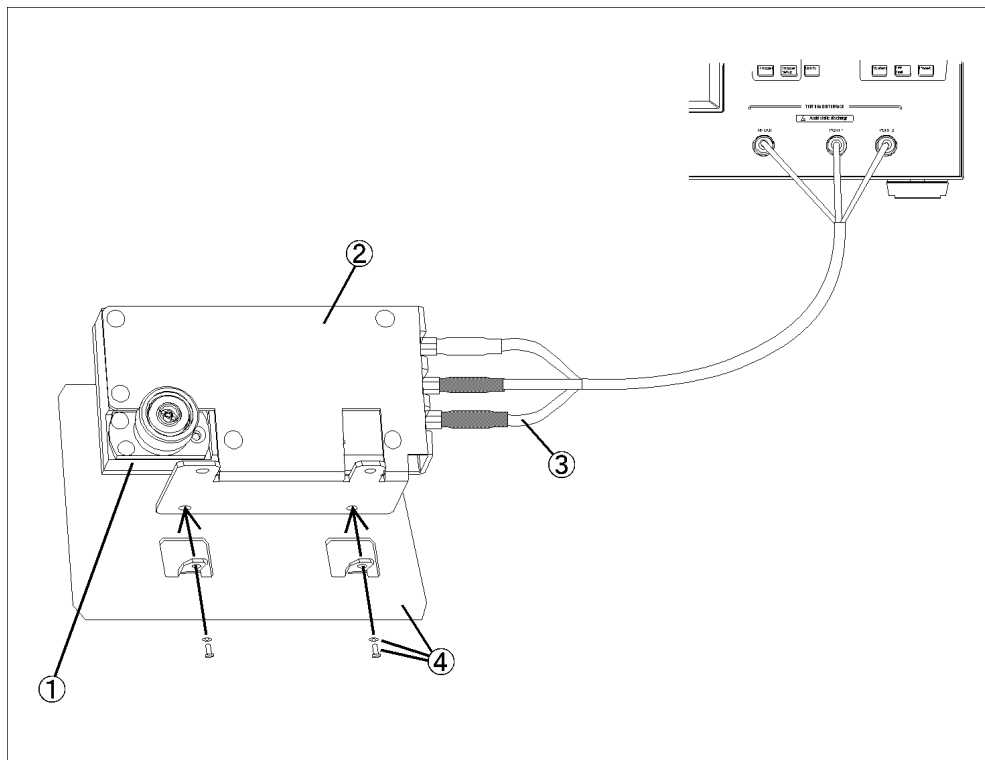
e4991u_opt00703

Table 6-26 Replaceable Pats of the Option 007

Ref. Desig.	Agilent Part Number	C/D	Qty.	Description
1	E4991-61610	5	1	CABLE ASSY HEAT-RESISTANT
2	E4991-01220	7	1	HOLDER CABLE
3	E4991-01221	8	1	HOLDER CABLE
4	0515-0372	2	4	SCREW-MACH M3X8 TORX T10 PAN
5	0515-1946	8	4	SCREW-MACH M3X6 TORX T10 90 DEG FLAT
6	E4991-60005	0	1	STAND TEST-FIXTURE
7	04287-61651	4	1	RF CABLE ASSY EXTENSION
8	E4991-60006	1	1	STAND TEST-HEAD
9	E4991-60032	3	1	TERMINATION OPEN
10	E4991-60031	2	1	TERMINATION SHORT
11	E4991-60060	7	1	CASE TEMPERATURE-COMPENSATION-SET
12	1250-2879	7	3	ADAPTER N (M) - SMA (F)
13	1250-3157	6	3	ADAPTER N (F) - SMA (F)
14	04291-09001	4	1	PAD
15	E4991-18001	7	1	DISK FLOPPY TEMP-CHARAC-TEST SOFTWARE
16	1400-0584	6	3	TIE CABLE

Test Head for Option 010

Figure 6-26 Test Head for Option 010



e4991ase133

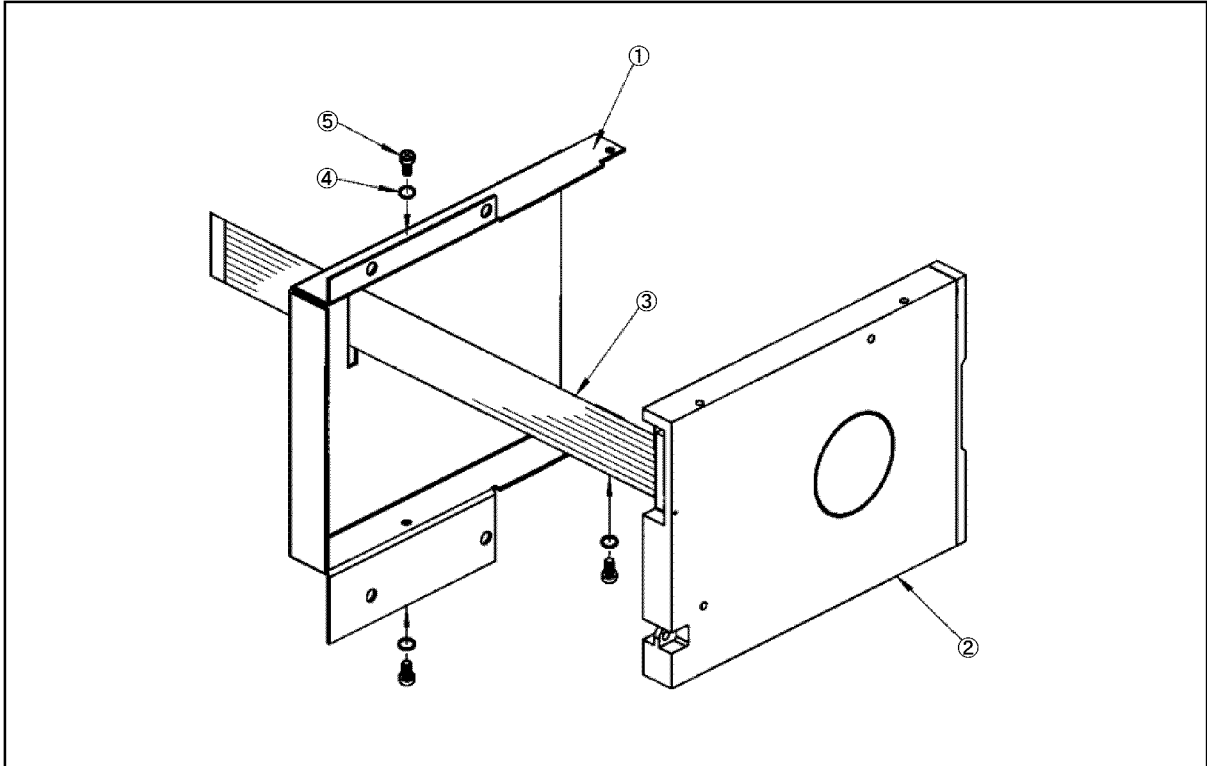
Table 6-27 Test Head for Option 010

Ref. Desig.	Agilent Part Number	C/D	Qty.	Description
1	E4991-60111	9	1	TEST HEAD
2	E4991-01210	5	1	ANGLE
3	04287-61651	4	1	EXTENSION CABLE ASSY
4	E4991-65002*1	3	1	TEST HEAD STAND FOR OPT.010

*1. for service use. Not furnished in option 010.

Floppy Disk Drive Assembly

Figure 6-27 Floppy Disk Drive Assembly



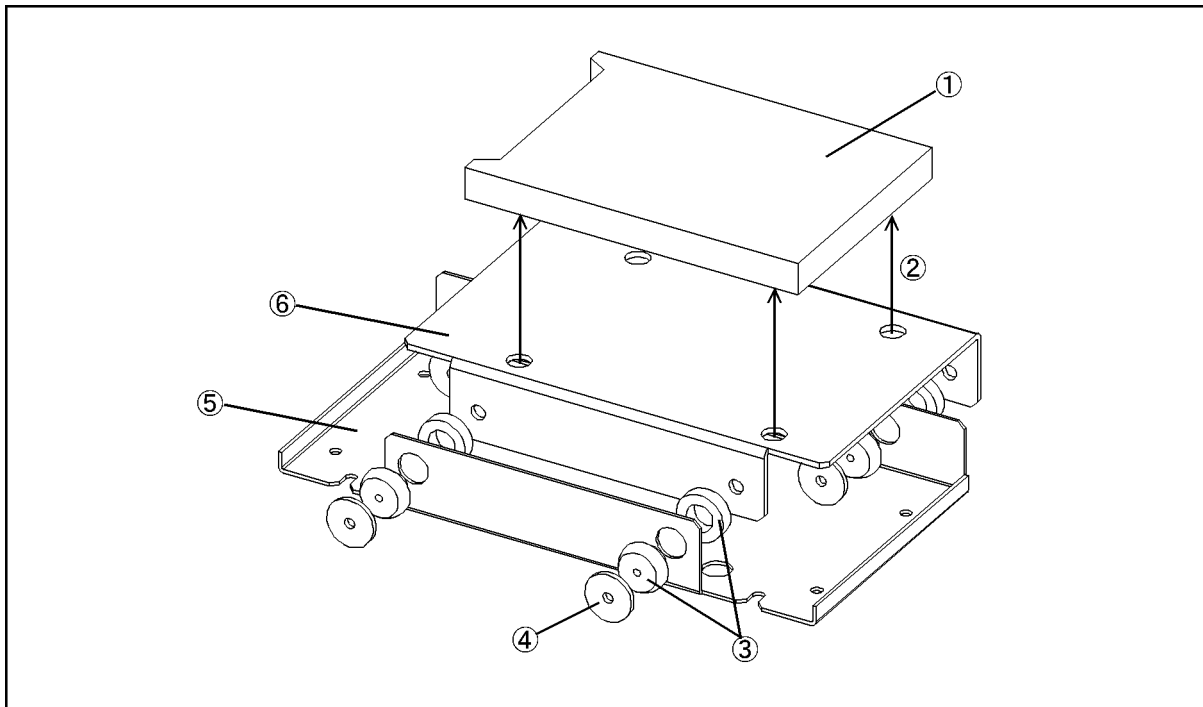
e4991ase096

Table 6-28 Floppy Disk Drive Assembly

Ref. Desig.	Agilent Part Number	C/D	Qty.	Description
1	0950-4325		1	A28 FLOPPY DISK DRIVE
2	04287-01203	6	1	FDD HOLDER
3	E5100-61661	1	1	CABLE FLAT 26PIN
4	2190-0583		3	M2.5 SPRING WASH
5	0515-1056	1	3	SCREW

Mass Storage Disk Drive Assembly

Figure 6-28 Mass Storage Disk Drive Assembly



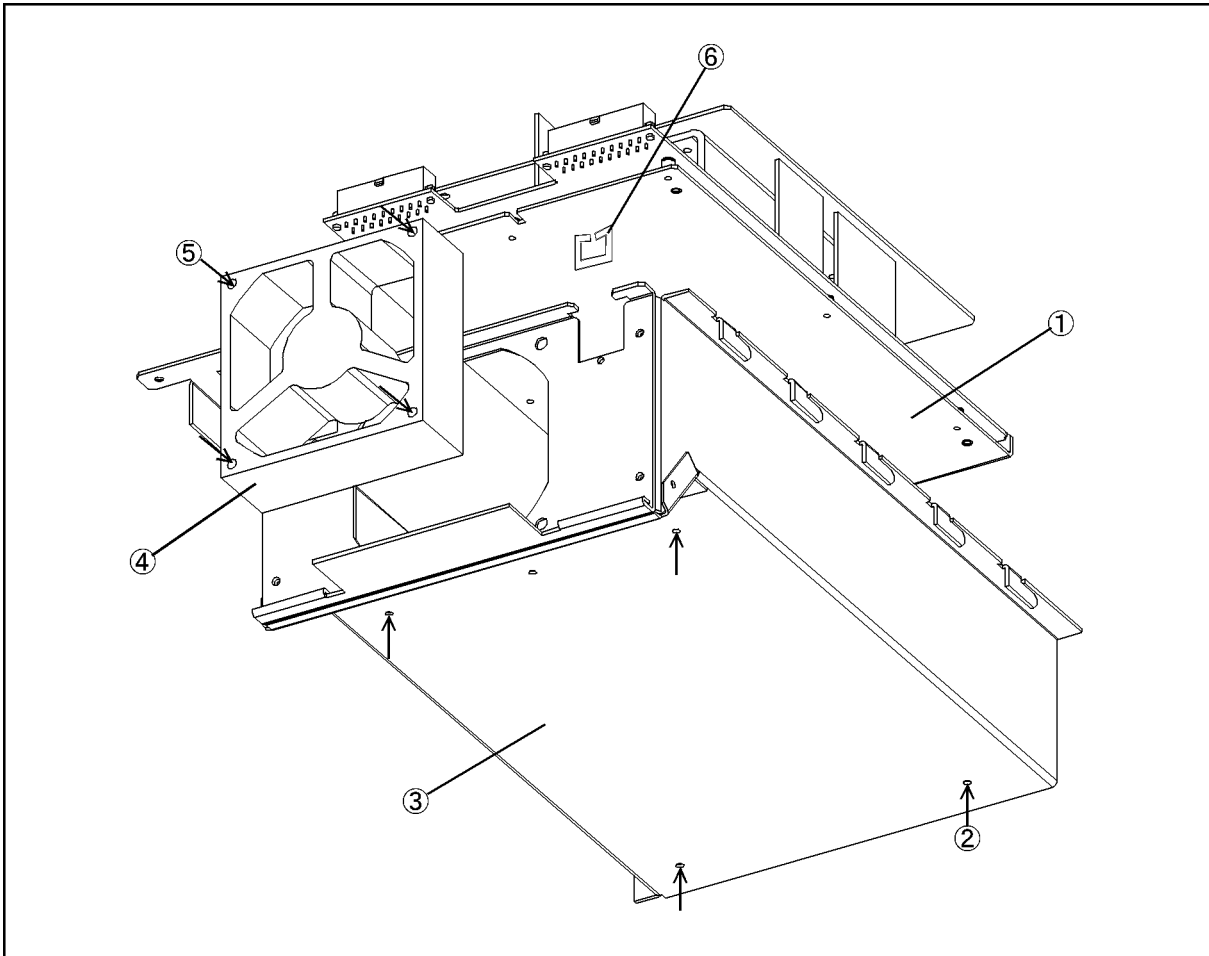
4287ase06013

Table 6-29 Mass Storage Disk Drive Assembly

Ref. Desig.	Agilent Part Number	C/D	Qty.	Description
1	E4991-61200		1	HDD INSTALLED
2	0515-0924	0	4	SCREW-MACH M3X0.5
3	1410-1580	5	4	BUSHING
4	E5070-24011		4	PLATE
5	04287-01211	6	1	HDD BRACKET
6	04287-01204	7	1	HDD HOLDER

Power Supply Assembly

Figure 6-29 Power Supply Assembly



4287ase06012

Table 6-30 Power Supply Assembly

Ref. Desig.	Agilent Part Number	C/D	Qty.	Description
1	0950-3396	8	1	PWR-SPLY-225W
2	0515-0924	0	2	SCREW-MACH M3X0.5
3	04287-60003	8	1	BRACKET P/S ASSY
4	04287-61001	8	1	FAN ASSY
5	0515-1666	9	4	SCREW M4X35 POZI
6	1400-2198	2	2	SADDLE-EDGE

Replaceable Parts
 Replaceable Parts List (for serial prefix MY433 and later)

Other Parts

Table 6-31 Other Parts

Agilent Part Number	C/D	Qty.	Description
E4991-900x0	4	1	OPERATION MANUAL
E4991-900x2	6	1	PROGRAMMING MANUAL
E4991-901x0	9	1	SERVICE MANUAL *1
E4991-180x0	0	1	SAMPLE PROGRAM SET
E4991-900x1	5	1	QUICK START GUIDE
E4991-905x0	9	1	CD-ROM (manual)
E4991-16000	2	1	RECOVERY FD 1.00
E4991-16101	4	1	CD-ROM SOFTWARE 1.00
1150-7846	6	1	MOUSE PS/2
1150-7970	7	1	KEYBOARD
8710-1766	2	1	TORQUE WRENCH
E4991-60021	0	1	SHORT TERMINATION *2
E4991-60022	1	1	OPEN TERMINATION *2
04287-60021	0	1	50 OHM TERMINATION *2
04287-60022	1	1	LOW-LOSS CAPACITOR *2
16195-60041	8	1	CARRYING CASE *2
16195-90030	8	1	OPERATION NOTE, 16195B *2

*1. Opt. 0BW only

*2. Included in 16195B Calibration Kit

7**Replacement Procedure**

This chapter provides procedure for removing and replacing the major assemblies in the E4991A RF Impedance/Material Analyzer.

Replacing an Assembly

The following steps show the sequence to replace an assembly in a E4991A RF Impedance/Material Analyzer.

1. Identify the faulty group. Refer to Chapter 4, “Troubleshooting.”
2. Order a replacement assembly. Refer to Chapter 6, “Replaceable Parts.”
3. Replace the faulty assembly and determine what adjustments are necessary. Refer to Chapter 7, “Replacement Procedure.” and Chapter 8, “Post-Repair Procedures.”
4. Perform the necessary adjustments. Refer to Chapter 3, “Adjustment.”
5. Perform the necessary performance tests. Refer to Chapter 2, “Performance Test and Function Test.”

WARNING These servicing instructions are for use by qualified personnel only. To avoid electrical shock, do not perform any servicing unless you are qualified to do so.

WARNING The opening of covers or removal of parts is likely to expose dangerous voltages. Disconnect the instrument from its power supply.

CAUTION Many of the assemblies in this instrument are very susceptible to damage from ESD(electrostatic discharge). Perform the following procedures only at a static-safe workstation and wear a grounding strap.

Required Tools

The following tools are required for repair of E4991A.

Table 7-1 Required Tools

Tool	Size	Purpose
Pozidriv screwdriver	pt size #2 (medium)	Outer Cover Removal A1/A2/A3/A4 Board Removal A10 Analog Motherboard Removal A22 Front Panel Keyboard Removal A51 LCD Removal A52 Inverter Board Removal
	pt size #1 (small)	A1/A2/A3/A4 Board Removal A5 Reference Oven Board Removal A10 Analog Motherboard Removal A20 Digital Motherboard Removal A27 Mass Storage Removal A28 FDD Removal A50 Power Supply Removal A51 LCD Removal A52 Inverter Board Removal
Torx screwdriver	T15	A20 Digital Motherboard Removal A24 GPIB/A25 LAN Board Removal A26 Display Board Removal A28 FDD Removal EEPROM Removal
Flat edge screwdriver	small	Front Panel Removal CPU Replacement
Open-end wrench	5/16-inch	A1/A2/A3/A4 Board Removal
Open-end torque wrench	5/16-inch(set to 10 in-lb)	A1/A2/A3/A4 Board Removal
PLCC extractor		EEPROM Removal
Soldering Iron		A22 Front Panel Keyboard Removal

Outer Cover Removal

Tools Required

- Pozidriv screwdriver, pt size #2 (medium)

Procedure

- Step 1.** Disconnect the power cable from the E4991A.
- Step 2.** Remove the four rear feet.
- Step 3.** Remove the six screws holding the outer cover from the rear side.
- Step 4.** Remove the side strap handles.
- Step 5.** Turn the E4991A over.
- Step 6.** Remove eight screws from the bottom side.
- Step 7.** Remove four bottom feet.

NOTE

If bottom feet is not be removed, outer cover won't be removed smooth.

- Step 8.** Put a plastic cover(p/n 5040-6973) on the front panel of the E4991A and place the E4991A on flat table with its front panel down.
- Step 9.** Slide up the outer cover and remove it carefully.

Front Panel Removal

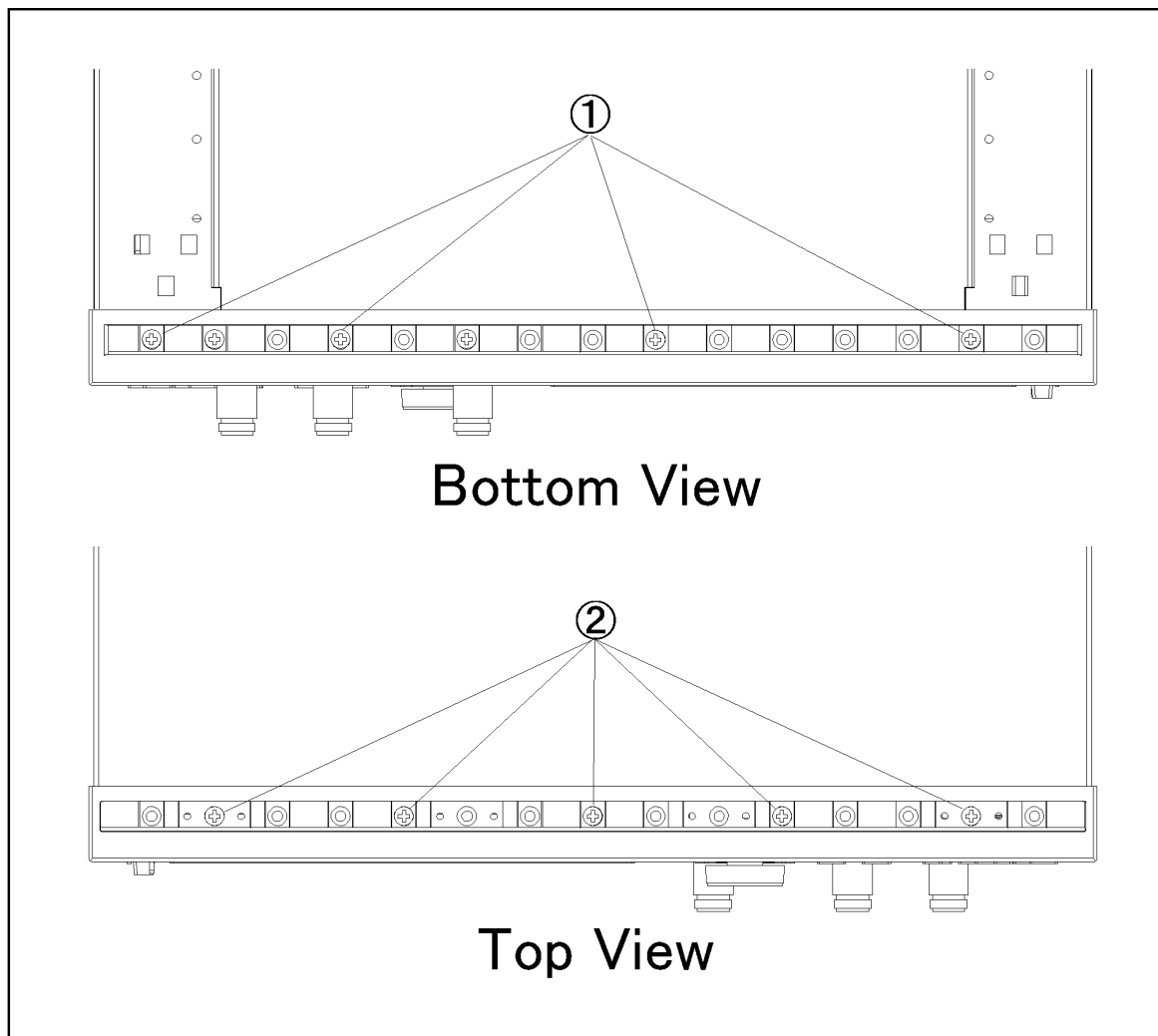
Tools Required

- Pozidriv screwdriver, pt size #2 (medium)
- Flat edge screwdriver

Procedure

- Step 1.** Remove the top trim with a flat edge driver.
- Step 2.** Remove the nine screws (item 1 and 2 in Figure 7-1) from the top and bottom side of the front frame.

Figure 7-1 Screws fastening Front Panel



e4991ase050

- Step 3.** Gradually pull the front panel assembly towards the front by holding knob.

A50 Power Supply Assembly Removal (for serial prefix JP1KH, JP2KH, and MY432)

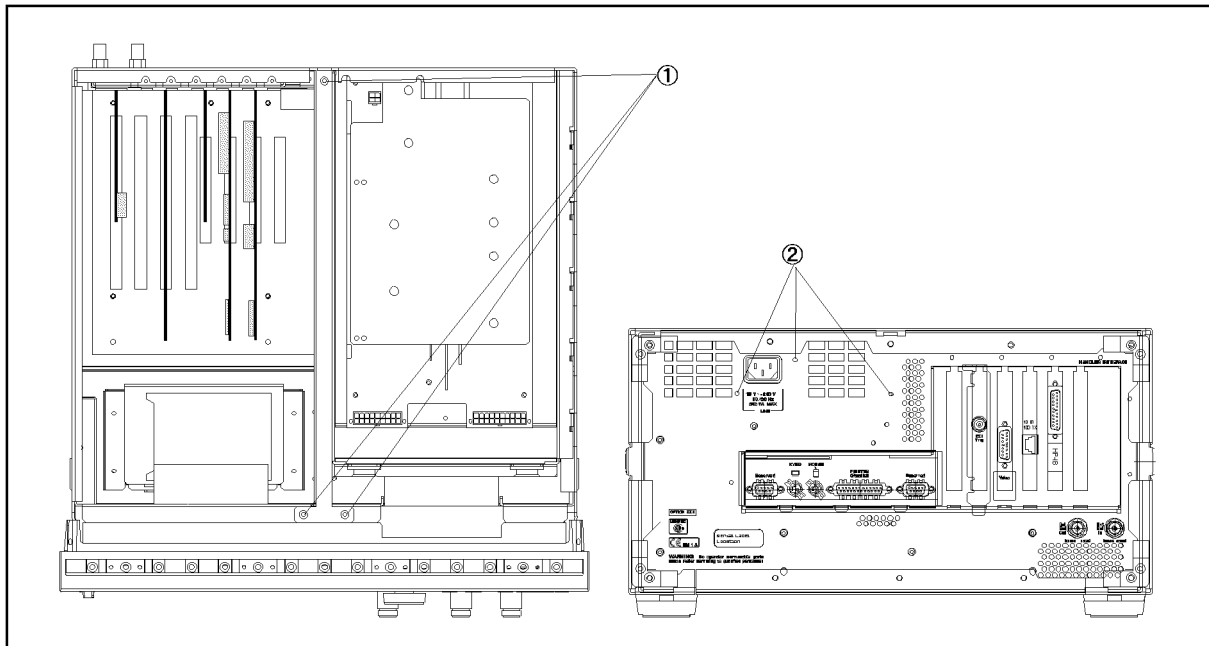
Tools Required

- Pozidriv screwdriver, pt size #1 (small)

Procedure

- Step 1.** Remove the outer cover as described in “Outer Cover Removal.”
- Step 2.** Disconnect the cables (item 9 and 10 in Figure 6-2 on page 234) connected to the power supply
- Step 3.** Remove the three flat head screws (item 1 in Figure 7-2) from top side.
- Step 4.** Remove the three screws (item 2 in Figure 7-2) from the rear panel.

Figure 7-2 Power Supply Assembly removal



e4991ase127

- Step 5.** Slide the power supply assembly toward front side, and lift it.

A50 Power Supply Assembly Removal (for serial prefix MY433 and later)

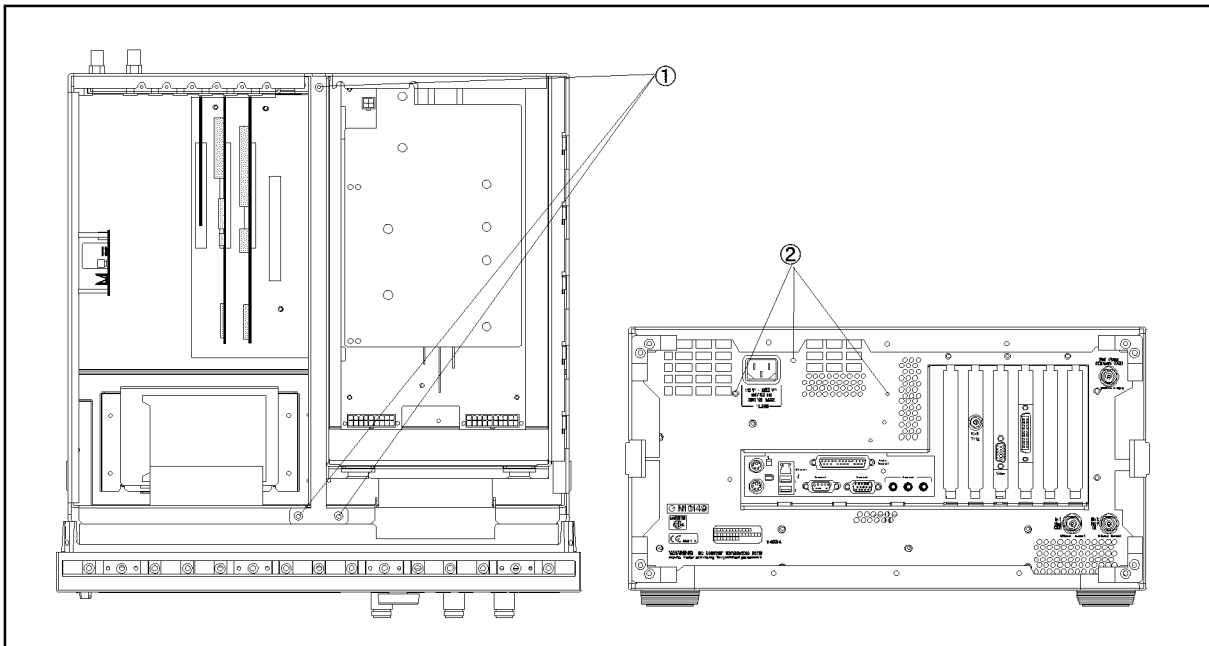
Tools Required

- Pozidriv screwdriver, pt size #1 (small)

Procedure

- Step 1.** Remove the outer cover as described in “Outer Cover Removal.”
- Step 2.** Disconnect the cables (item 11 and 12 in Figure 6-16 on page 258) connected to the power supply
- Step 3.** Remove the three flat head screws (item 1 in Figure 7-2) from top side.
- Step 4.** Remove the three screws (item 2 in Figure 7-2) from the rear panel.

Figure 7-3 Power Supply Assembly removal



e4991ase103

- Step 5.** Slide the power supply assembly toward front side, and lift it.

A27 Mass Storage Disk Drive Assembly Removal

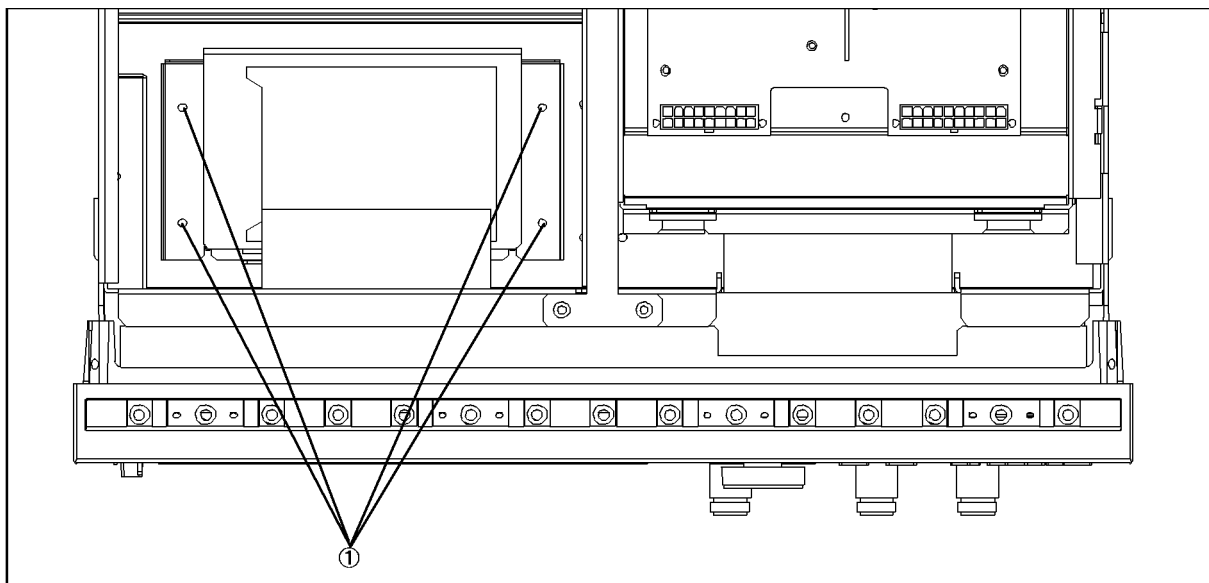
Tools Required

- Pozidriv screwdriver, pt size #1 (small)

Procedure

- Step 1.** Remove the outer cover as described in “Outer Cover Removal.”
- Step 2.** Disconnect all cables (item 6 in Figure 6-2 on page 234) connected to the mass storage disk drive.
- Step 3.** Remove four screws (item 1 in Figure 7-4) fastening the mass storage disk drive assembly to the chassis.

Figure 7-4 Mass Storage Disk Drive Assembly



4287ase07004

- Step 4.** Slide the assembly toward rear side, and lift it.
- Step 5.** Disassemble the mass storage disk drive as shown in Figure 6-13 on page 253.
- Step 6.** Install the new mass storage disk drive. Then recovery the backuped files, if you backuped the user files. Install the latest firmware, if it is not installed in the mass storage disk drive.

A28 FDD (Floppy Disk Drive) Removal

Tools Required

- Pozidriv screwdriver, pt size #1 (small)
- Torx screwdriver, T15

Procedure

- Step 1.** Remove the outer cover as described in “Outer Cover Removal”
- Step 1.** Remove the front panel as described in “Front Panel Removal”
- Step 2.** Remove four screws fastening the side panel on the LCD side to the FDD folder.
- Step 3.** Remove four screws fastening the FDD folder to FDD.
- Step 4.** Remove the FDD from the FDD folder.
- Step 5.** Disconnect the mylar ribbon cable (item 5 in Figure 6-2 on page 234) at the FDD.

NOTE

The mylar ribbon cable and their connector are fragile. You must be attentive as described in NOTE on page 301 when you are instructed to disconnect or connect it.

A20 Digital Motherboard Removal (for serial prefix JP1KH, JP2KH, and MY432)

Tools Required

- Pozidriv screwdriver, pt size #1 (small)
- Torx screwdriver, T15

Procedure

- Step 1.** Remove the mouse, the external keyboard and the parallel printer cable if they are connected to the rear panel.
- Step 2.** Remove the outer cover as described in “Outer Cover Removal”
- Step 3.** Remove the power supply as described in “A50 Power Supply Assembly Removal (for serial prefix JP1KH, JP2KH, and MY432)”
- Step 4.** Disconnect the following cables.
- A20 to A26 Display board IDE1 flat cable (item 1 in Figure 6-2 on page 234)
 - A20 to A26 Display board floppy flat cable (item 2 in Figure 6-2)
 - A20 to A10 Analog Motherboard power supply cable (item 3 in Figure 6-2)
- Step 5.** Remove the following boards.
- A21 Analog Interface board as described in “A21 Analog Interface Board and EEPROM Removal”
 - A24 GPIB board as described in “A24 GPIB/A25 LAN Board Removal (for serial prefix JP1KH, JP2KH, and MY432)”
 - A25 LAN board as described in “A24 GPIB/A25 LAN Board Removal (for serial prefix JP1KH, JP2KH, and MY432)”
 - A26 Display board as described in “A26 Display Board Removal”
- Step 6.** Remove seven screws fastening the A20 to the bottom panel and remove the A20.
- Step 7.** Remove the CPU and CPU fan as described in “CPU Replacement (for serial prefix JP1KH, JP2KH, and MY432)”.
- Step 8.** Remove the DIMM64MB modules as described in “DIMM64MB Memory Module Replacement (for serial prefix JP1KH, JP2KH, and MY432)”.

NOTE

To replace the A20, reverse the above procedure. And, configure the several jumpers and BIOS parameters as described in “To Configure the A20 Digital Motherboard and BIOS (for serial prefix JP1KH, JP2KH, and MY432)” on page 195.

A20 Digital Motherboard Removal (for serial prefix MY433 and later)

Tools Required

- Pozidriv screwdriver, pt size #1 (small)
- Torx screwdriver, T15

Procedure

- Step 1.** Remove the mouse, the external keyboard and the parallel printer cable if they are connected to the rear panel.
- Step 2.** Remove the outer cover as described in “Outer Cover Removal”
- Step 3.** Remove the power supply as described in “A50 Power Supply Assembly Removal (for serial prefix MY433 and later)”
- Step 4.** Disconnect the following cables.
- A26 to A20 Digital Motherboard floppy flat cable (item 1 in Figure 6-16 on page 258)
 - A26 to A20 IDE1 flat cable (item 2 in Figure 6-16)
 - A26 to LCD mylar ribbon cable (item 4 in Figure 6-16)
 - A26 to Floppy mylar ribbon cable (item 7 in Figure 6-16)
 - A26 to A27 Mass Storage Disk Drive flat cable (item 8 in Figure 6-16)
 - A26 to Backlight primary cable (item 9 in Figure 6-16)
 - A21 to the A10 Analog Motherboard flat cable (item 3 in Figure 6-16)
 - A21 to the A22 Front Panel Keyboard flat cable (item 10 in Figure 6-16)
 - A21 to the system fan cables
- Step 5.** Remove the following boards.
- A21 Analog Interface board as described in “A21 Analog Interface Board and EEPROM Removal”
 - A24 GPIB board as described in “A24 GPIB Card Replacement (for serial prefix MY433 and later)”
 - A26 Display board as described in “A26 Display Board Removal”
- Step 6.** Remove five screws fastening the A20 to the bottom panel and remove the A20.

NOTE

To replace the A20, reverse the above procedure. And, configure the several jumpers and BIOS parameters as described in “To Configure the A20 Digital Motherboard and BIOS (for serial prefix MY433 and later)” on page 208.

CPU Replacement (for serial prefix JP1KH, JP2KH, and MY432)

There is a CPU on the A20 Digital Motherboard.

Tools Required

- Flat edge screwdriver

Procedure

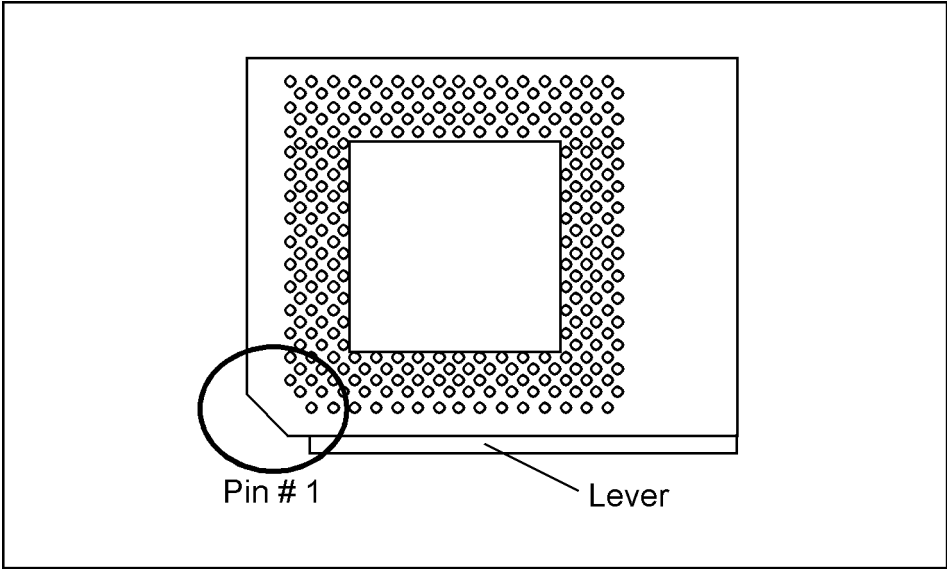
NOTE

Always handle the CPU by the edges, never touch the pins.

- Step 1.** Remove the outer cover as described in “Outer Cover Removal”
- Step 2.** Remove the power supply as described in “A50 Power Supply Assembly Removal (for serial prefix JP1KH, JP2KH, and MY432)”
- Step 3.** Disconnect the CPU fan cable from J16 CPU fan connector.
- Step 4.** Separate the heatsink clip from the CPU socket tabs using the flat edge screwdriver.
- Step 5.** Pull the CPU socket release lever laterally away from the CPU socket to disengage the level from the locking tab. Then rotate the lever upward to release the CPU from the CPU socket.
- Step 6.** Lift the CPU out of the socket.
- Step 7.** To replace the CPU, reverse the CPU removal procedure. Install the CPU so that pin 1 on the CPU aligns with pin 1 of the CPT socket as shown in Figure 7-5. The diagonal notch on the CPU represents pin 1.

Figure 7-5

CPU Socket Alignment



4287ase07005

DIMM64MB Memory Module Replacement (for serial prefix JP1KH, JP2KH, and MY432)

There are two DIMM64MB memory module on the A20 Digital Motherboard.

Procedure

- Step 1.** Remove the outer cover as described in “Outer Cover Removal”.
- Step 2.** Remove the power supply as described in “A50 Power Supply Assembly Removal (for serial prefix JP1KH, JP2KH, and MY432)”.
- Step 3.** There are three DIMM sockets on the A20. Two DIMM memory modules are installed at the socket U12 and U13.
- Step 4.** Cut the cable tie which ties DIMM memory.
- Step 5.** Unlatch the two clips and remove the DIMM memory.
- Step 6.** To replace the DIMM memory, reverse the above procedure. Install the DIMM memory in the socket and latch the clips. Tie the DIMM memory and the socket using the cable tie.

A1/A2(Opt.001)/A3/A4 Board Removal

Tools Required

- Pozidriv screwdriver, pt size #1 (small) and #2 (medium)
- Open-end wrench, 5/16-inch
- Open-end torque wrench, 5/16-inch (set to 10 in-lb) (for reconnecting SMA connector)

Procedure

- Step 1.** Remove the outer cover as described in “Outer Cover Removal.”
- Step 2.** Remove the front frame as described in “Front Panel Removal”
- Step 3.** Disconnect the semi-rigid cables connected to the board assembly.
- Step 4.** Remove the two screws fastening the extractor to the chassis.

NOTE

Remove the two nuts (item 1 in Figure 6-8 on page 245) fastening the BNC connector on the rear panel when the A1 is removed.

Remove the two screws fastening the front frame to the bracket connect (item 3 in Figure 6-5 on page 240) when the A4 is removed.

Step 5. Remove the board using the extractor.

A5 Reference Oven Board(Opt.1D5) Removal

Tools Required

- Pozidriv screwdriver, pt size #1 (small)

Procedure

- Step 1.** Remove the outer cover as described in “Outer Cover Removal.”
 - Step 2.** Remove the two cables (item 11 and 12 in Figure 6-2 on page 234) connected to the A5.
 - Step 3.** Remove three screws on left side panel.
 - Step 4.** Remove the A5.
-

A10 Analog Motherboard Removal

Tools Required

- Pozidriv screwdriver, pt size #1 (small) and #2 (medium)

Procedure

- Step 1.** Remove the outer cover as described in “Outer Cover Removal”
- Step 2.** Remove the front frame as described in “Front Panel Removal”
- Step 3.** Remove the A20 Digital Motherboard as described in “A20 Digital Motherboard Removal (for serial prefix JP1KH, JP2KH, and MY432)”.
- Step 4.** Remove the A1, A2(Opt.001), A3, A4 boards as described in “A1/A2(Opt.001)/A3/A4 Board Removal”.
- Step 5.** Remove the three screws fastening the cover (item 5 in Figure 6-4 on page 238) to the chassis assembly and remove the cover.
- Step 6.** From the outer side of the rear panel, remove the two screws fastening the rear panel to the A10.
- Step 7.** From the inner side of the rear panel, remove the eight screws fastening the rear panel to the A10 and remove the A10.

A21 Analog Interface Board and EEPROM Removal

Tools Required

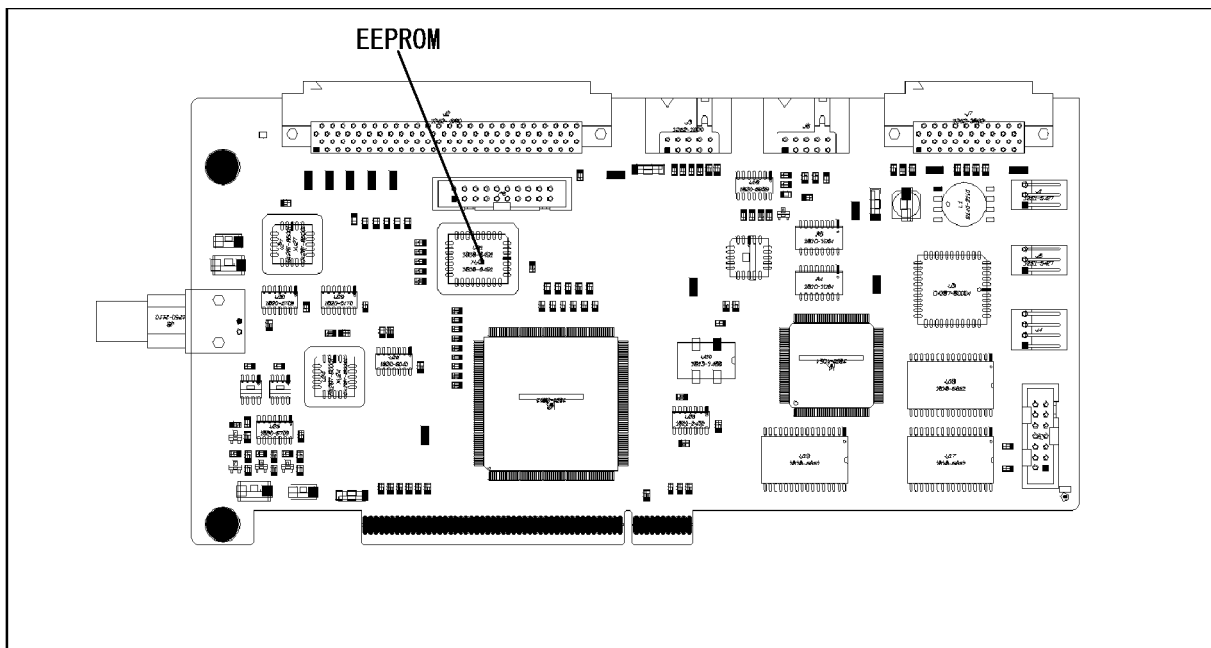
- PLCC extractor
- Torx screwdriver, T15

Procedure

- Step 1.** Remove the outer cover as described in “Outer Cover Removal”.
- Step 2.** Disconnect the following cables from the A21 Analog Interface board.
 - A21 to the A10 Analog Motherboard flat cable (item 3 in Figure 6-2)
 - A21 to the A22 Front Panel Keyboard flat cable (item 8 in Figure 6-2 on page 234)
 - A21 to the system fan cables
- Step 3.** Remove a torx screw fastening the A21 to the rear panel.
- Step 4.** Remove the A21.
- Step 5.** Remove the EEPROM from the original board, then mount it on the new board. Because, the adjustment data is stored in the EEPROM. If the EEPROM is defective, it is necessary to perform all adjustments after replacing it.

Figure 7-6

EEPROM



4287ase07002

A24 GPIB/A25 LAN Board Removal (for serial prefix JP1KH, JP2KH, and MY432)

Tools Required

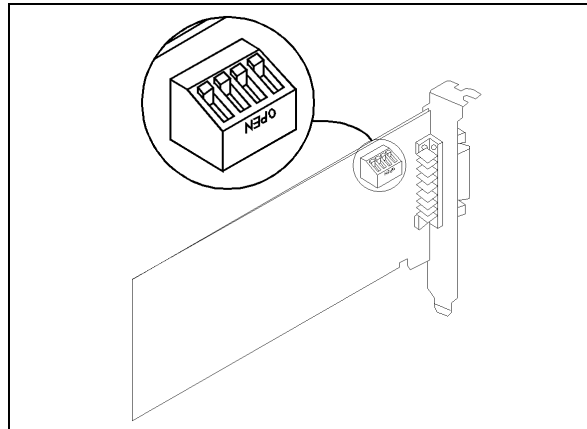
- Torx screwdriver, T15

Procedure

- Step 1.** Remove the outer cover as described in “Outer Cover Removal”
- Step 2.** Remove a torx screw fastening the board to the rear panel.
- Step 3.** Remove the board.

Figure 7-7

Assignment of the Bit switches on the A24 GPIB board



4287ase07006

A24 GPIB Card Replacement (for serial prefix MY433 and later)

Tools Required

- Pozidriv screwdriver, pt size #2 (medium) (where Pozidriv screws are in use)
- TORX screwdriver, T15, (T10, T20 where TORX screws are in use)

Removal Procedure

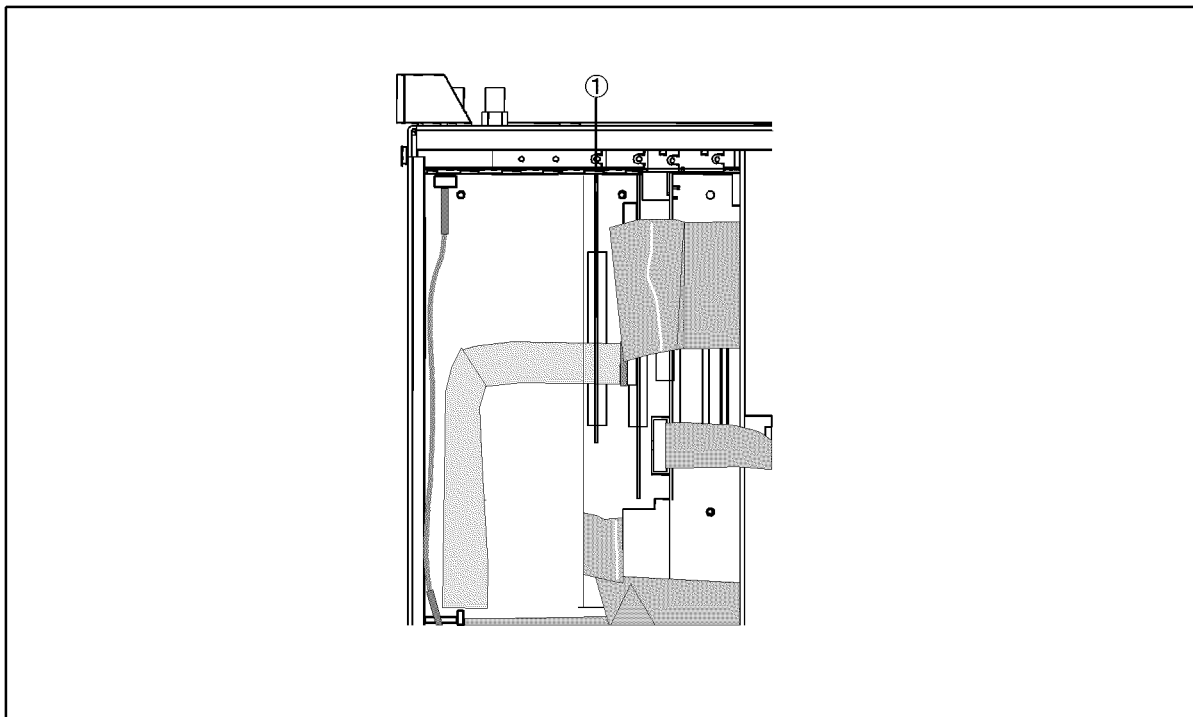
Refer to Figure 7-8 for this procedure.

- Step 1.** Remove the outer cover as described in “Outer Cover Removal”.
- Step 2.** Remove the TORX T15 screw (item 1) fastening the card to the rear panel.
- Step 3.** Lift the A24 GPIB Card.

CAUTION

Be careful not to injure the digital mother board and the cable connected the display board to the front assembly.

Figure 7-8 A24 GPIB Card Removal



e4991ase104

Replacement Procedure

A24 GPIB Card Replacement (for serial prefix MY433 and later)

Replacement Procedure

- Replace the new A24 GPIB card by inverse procedure of removal.

A26 Display Board Removal

Tools Required

- Torx screwdriver, T15

Procedure

- Step 1.** Remove the outer cover as described in “Outer Cover Removal”
- Step 2.** Disconnect the following cables from the A26 Display board.
 - A26 to Floppy mylar ribbon cable (item 5 in Figure 6-2 on page 234)
 - A26 to A27 Mass Storage Disk Drive flat cable (item 6 in Figure 6-2)
 - A26 to A20 Digital Motherboard floppy flat cable (item 2 in Figure 6-2)
 - A26 to A20 IDE1 flat cable (item 1 in Figure 6-2)
 - A26 to Backlight primary cable (item 7 in Figure 6-2)
 - A26 to LCD mylar ribbon cable (item 4 in Figure 6-2)
- Step 3.** Remove a torx screw fastening the A26 to the rear panel.
- Step 4.** Remove the A26.

NOTE

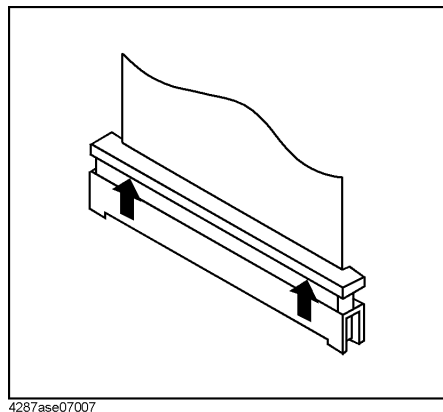
Use the following procedure when you handle the mylar ribbon cable. The mylar cable and their connector are very fragile. To replace to a new mylar cable is recommended when you are instructed to disconnect and connect the mylar cable frequently.

To disconnect the cable:

- Step 1.** Pry up the retainer slightly at either end of the connector as shown in Figure 7-9, using a small flat-blade screwdriver.

Figure 7-9

pry up the retainer



- Step 2.** Pull the mylar ribbon cable out of the connector.

A22 Front Panel Keyboard Removal

Tools Required

- Pozidriv screwdriver, pt size #1 (small) and #2 (medium)
- Soldering Iron

Procedure

- Step 1.** Remove the front panel as described in “Front Panel Removal”.
- Step 2.** Remove the six screws fastening the LCD cover to the front panel.
- Step 3.** Disconnect the flat cable (item 8 in Figure 6-2 on page 234) from the A22 Front Panel Keyboard.
- Step 4.** Remove the eight screws fastening the A22 to the front panel.
- Step 5.** Remove the front panel knob to remove the A22.
- Step 6.** Remove two screws fastening the LED board to the front panel. The LED board is connected to the A22 using the four wire cables.
- Step 7.** Remove the two wire cables from the power switch assembly (item 13 in Figure 6-2) using a soldering iron.
- Step 8.** Remove the A22.

A51 LCD Removal

Tools Required

- Pozidriv screwdriver, pt size #1 (small) and #2 (medium)

Procedure

- Step 1.** Remove the front panel as described in “Front Panel Removal”.
- Step 2.** Remove the six screws fastening the LCD cover to the front panel.
- Step 3.** Disconnect the flat cable (item 8 in Figure 6-2 on page 234) from the A22 Front Panel Keyboard.
- Step 4.** Disconnect the two backlight cables from the Inverter board as described in “A52 Inverter Board Removal”.
- Step 5.** Remove the four screws fastening the LCD to the LCD cover and remove the LCD.
- Step 6.** Remove the mylar ribbon cable (item 4 in Figure 6-2) from the LCD and remove the LCD.

NOTE

The mylar ribbon cable and their connector are fragile. You must be attentive as described in NOTE on page 301 when you are instructed to disconnect or connect it.

A52 Inverter Board Removal

Tools Required

- Pozidriv screwdriver, pt size #1 (small) and #2 (medium)

Procedure

- Step 1.** Remove the front panel as described in “Front Panel Removal”.
- Step 2.** Remove the two screws fastening the Inverter board cover to the LCD cover and remove the cover.
- Step 3.** Disconnect the backlight primary cable (item 7 in Figure 6-2) from the Inverter board.
- Step 4.** Disconnect the two backlight cables from the Inverter board.
- Step 5.** Remove the two screws fastening the Inverter board to the LCD cover and remove the Inverter board.

Replacement Procedure
A52 Inverter Board Removal

8 Post-Repair Procedures

This chapter lists the procedures required to verify the E4991A operation after an assembly is replaced with a new one.

Post-Repair Procedures

Table 8-1 *Post Repair Procedures* lists the required procedures that must be performed after the replacement of an assembly, CPU, DIMM(Memory) or the EEPROM. These are the recommended minimum procedures to ensure that the replacement is successfully completed.

Table 8-1 Post-Repair Procedures

Replaced Assembly or Part	Required Adjustments Correction Constants (CC)	Verification
A1 Reference Oscillator Board	Perform the following required adjustments using the A1 Adjustment in Spot Adjustment of the program. A1 VCXO Frequency Adjustment A3 Local Level Adjustment A3 Output AGC Gain Adjustment A3 Output Level Adjustment A4 Local AGC Gain Adjustment A4 Local level Adjustment A4 IF Local AGC Gain Adjustment Default Cal Coefficient Adjustment System Backup	“To Execute the Internal Test” on page 170 “To Execute the External Test” on page 187 Frequency Accuracy Test Power Level Accuracy Test Impedance Measurement Accuracy Test
A2 DC Bias Board (Opt 001)	Perform the following required adjustments using the A2 Adjustment in Spot Adjustment of the program. A2 DC Bias Voltage Adjustment A2 DC Bias Current Adjustment A2 DC Bias RC Adjustment System Backup	“To Execute the Internal Test” on page 170 “To Execute the External Test” on page 187 DC Bias Test Impedance Measurement Accuracy Test
A3 Source Board	Perform the following required adjustments using the A3 Adjustment and A2 Adjustment(Opt.001) in Spot Adjustment of the program. A3 Local Level Adjustment A3 Output AGC Gain Adjustment A3 Output Level Adjustment A4 Local AGC Gain Adjustment A4 Local level Adjustment A4 IF Local AGC Gain Adjustment Default Cal Coefficient Adjustment A2 DC Bias Voltage Adjustment A2 DC Bias Current Adjustment A2 DC Bias RC Adjustment System Backup	“To Execute the Internal Test” on page 170 “To Execute the External Test” on page 187 Power Level Accuracy Test Impedance Measurement Accuracy Test Frequency Accuracy Test DC Bias Test

Table 8-1 Post-Repair Procedures

Replaced Assembly or Part	Required Adjustments Correction Constants (CC)	Verification
A4 Receiver Board	Perform the following required adjustments using the A4 Adjustment and A2 Adjustment(Opt.001) in Spot Adjustment of the program. A4 Local AGC Gain Adjustment A4 Local level Adjustment A4 IF Local AGC Gain Adjustment Default Cal Coefficient Adjustment A2 DC Bias Voltage Adjustment A2 DC Bias Current Adjustment A2 DC Bias RC Adjustment System Backup	“To Execute the Internal Test” on page 170 “To Execute the External Test” on page 187 Impedance Measurement Accuracy Test DC Bias Test
A5 Frequency Reference(Opt 1D5)	Perform the following required adjustment using the A5 Adjustment in Spot Adjustment of the program. A5 Reference Oven Adjustment	Frequency Accuracy Test(with Option 1D5)
A6 Test Head Board	Perform the following required adjustments using the A3 Adjustment and A2 Adjustment(Opt.001) in Spot Adjustment of the program. A3 Output Level Adjustment A4 IF Gain Adjustment Default Cal Coefficient Adjustment A2 DC Bias Voltage Adjustment A2 DC Bias Current Adjustment A2 DC Bias RC Adjustment System Backup	“To Execute the External Test” on page 187 Power Level Accuracy Test Impedance Measurement Accuracy Test DC Bias Test
A10 Analog Motherboard	Not Required	Inspect the Booting Process When the symptom of failure is out of specification, perform the performance test.
A20 Digital Motherboard	Set jumpers and BIOS parameters on the A20. For details, see “To Configure the A20 Digital Motherboard and BIOS (for serial prefix JP1KH, JP2KH, and MY432)” on page 195.	Inspect the Booting Process
A21 Analog Interface Board	Not Required	Inspect the Booting Process “To check the Front Panel” on page 177 “To check the External Trigger Input” on page 179

Post-Repair Procedures
Post-Repair Procedures

Table 8-1 Post-Repair Procedures

Replaced Assembly or Part	Required Adjustments Correction Constants (CC)	Verification
A22 Front Panel Keyboard	Not Required	“To Execute the External Test” on page 187 “To check the Front Panel” on page 177
A24 GPIB Board	Not Required	“To check the GPIB” on page 186
A25 LAN Interface Board	Not Required	“To check the LAN (for serial prefix JP1KH, JP2KH, and MY432)” on page 179
A26 Display Board	Not Required	Inspect the Booting Process “To Execute the External Test” on page 187 “To check the VGA Display Output” on page 178
A27 Mass Storage Disk Drive	All Adjustments. System Backup	Inspect the Booting Process Perform the all Performance Tests
A28 FDD	Not Required	“To check the FDD” on page 178
A50 Power Supply Assembly	Not Required	Inspect the Booting Process
A51 LCD	Not Required	Inspect the Booting Process “To Execute the External Test” on page 187 “To check the LCD” on page 177
A52 Inverter Board	Not Required	Inspect the Booting Process “To Execute the External Test” on page 187
CPU 400MHz	Not Required	Inspect the Booting Process
DIMM 64Mbyte	Not Required	Inspect the Booting Process
EEPROM on the A21	Write ID (Serial No. and Option No.) EEPROM Initialize All Adjustments. System Backup	Inspect the Booting Process Perform the all Performance Tests

A **Manual Changes**

This appendix contains the information required to adapt this manual to versions or configurations of the E4991A manufactured earlier than the current printing date of this manual. The information in this manual applies directly to E4991A units with the serial number that is printed on the title page of this manual.

Manual Changes

To adapt this manual to your E4991A, refer to Table A-1 and Table A-2.

Table A-1 **Manual Changes by Serial Number**

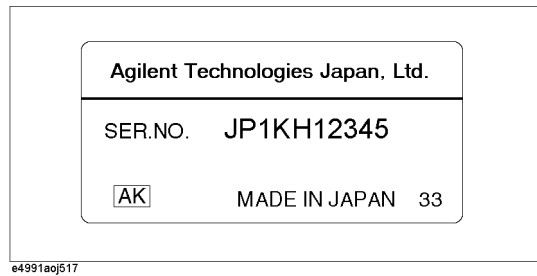
Serial Prefix or Number	Make Manual Changes

Table A-2 **Manual Changes by Firmware Version**

Version	Make Manual Changes

Agilent Technologies uses a two-part, ten-character serial number that is stamped on the serial number plate (Figure A-1). The first five characters are the serial prefix and the last five digits are the suffix.

Figure A-1 **Serial Number Plate (Example)**



e4991aaj517

B System Installation for A27 Mass Storage

This appendix describes how to install the operation system (Windows 98) to the A27 mass storage. When the operating system in the A27 mass storage has damage, you can recover it before replacing the A27 by the following procedure.

System Recovery (for serial prefix JP1KH, JP2KH, and MY432)

The E4991A has a backup file in the H drive (Hidden Drive) of the A27 mass storage which includes a compression image of the system files, application files, and calibration constant data. You can recover these files using the following procedure when the operating system in the A27 mass storage has damage.

NOTE

There are two types of the system recovery. This section describes the procedure for each system recovery.

- Procedure for the E4991As that have serial number prefixed JP1KH and their A27 mass storage has never been replaced.
 - Procedure for the E4991As that do not have serial number prefixed JP1KH or their A27 mass storage has been replaced.
-

Notes on executing system recovery

Performing system recovery causes the following:

- The following settings of the E4991A are initialized.
 - Network settings
 - GPIB settings
 - Printer settings
- If the firmware has been updated after purchasing the E4991A, the firmware when you purchased the product*¹ is recovered.

Files you created using the save function are not affected, but we recommend backing them up before executing system recovery for precautionary purposes.

NOTE

If the E4991A is turned off without shutdown process, Microsoft Scandisk runs after E4991A logo is displayed. If serious trouble is found during the scan disk, reinstall the operating system. And if the operating system still doesn't boot properly after reinstallation, A27 has to be replaced physically.

And, if you encounter the following problems, try to reinstall the operating system before replacing the A27.

- "xxx file is missing" is displayed on the DOS screen.
 - The E4991A logo screen is not displayed after "Searching for Boot Record from IDE-0 .. OK" is displayed.
 - Windows always boots with Safe Mode.
-

*1. If the hard disk failed and has been replaced after purchase, the state when the replacement was performed is recovered.

Procedure to execute system recovery (for serial number JP1KH and A27 that has never been replaced)

- Step 1.** Connect the external keyboard to the E4991A.
- Step 2.** Insert the system recovery disk (furnished with the E4991A) in the floppy disk drive of the E4991A.
- Step 3.** Turn the E4991A on.
- Step 4.** Press **[F]** key on the external keyboard as soon as the AMI BIOS System Configuration Display as shown in Figure B-1 is displayed after RAM counting.

Figure B-1

AMIBIOS System Configuration Display

AMIBIOS System Configuration (C) 1985-1997, American Megatrends Inc.,							
Main Processor : AMD-K6-2-/400				Base Memory Size : 640KB			
Math Processor : Built-In				Ext. Memory Size : 64512KB			
Floppy Drive A: : 1.44 MB 3 1/2"				Display Type : VGA/EGA			
Floppy Drive B: : None				Serial Port(s) : 3F8, 2F8			
AMIBIOS Date : 07/15/95				Parallel Port(s) : 378			
External Cache : 512KB, Disabled				Power Management : APM, SMI			
ATA(PI) Device(s)	Type	Size	LBA Mode	32Bit Mode	Block Mode	PIO Mode	
Primary Master	: Hard Disk	8064MB	LBA	Off	16Sec	4	
PCI Devices:							
PCI Onboard Bridge Device				PCI Onboard USB Controller, IRQ9			
PCI Onboard IDE				PCI Slot 1 Ethernet, IRQ10			
PCI Slot 2 VGA				PCI Slot 3 Unknown Device, IRQ11			

e4991ase069

The contents of the system recovery disk are loaded while Figure B-2 is displayed. After a short time, the system recovery start screen as shown in Figure B-3 is displayed.

System Installation for A27 Mass Storage
System Recovery (for serial prefix JP1KH, JP2KH, and MY432)

Figure B-2

Searching File Display

AMIBIOS System Configuration (C) 1985-1997, American Megatrends Inc.,							
Main Processor	:	AMD-K6-2-/400		Base Memory Size	:	640KB	
Math Processor	:	Built-In		Ext, Memory Size	:	64512KB	
Floppy Drive A:	:	1.44 MB 3 1/2"		Display Type	:	VGA/EGA	
Floppy Drive B:	:	None		Serial Port(s)	:	3F8, 2F8	
AMIBIOS Date	:	07/15/95		Parallel Port(s)	:	378	
Power Management	:	APM, SMI					
ATA(PI) Device(s)	Type	Size		LBA Mode	32Bit Mode	Block Mode	PIO Mode
Primary Master	: Hard Disk	8064MB		LBA	Off	16Sec	4
PCI Devices:				PCI Onboard USB Controller, IRQ9			
PCI Onboard Bridge Device				PCI Slot 1 Ethernet, IRQ10			
PCI Onboard IDE				PCI Slot 3 Unknown Device, IRQ11			
PCI Slot 2 VGA							

Searching for Boot Record from Floppy..OK

e4991ase070

Figure B-3

System Recovery Start Screen

Product: E4991A system recovery disk
 Rev: 1.00

Copyright (C) 2001 Agilent Technologies, Inc.
 All right reserved.

This program will recover the C-drive of this
 instruments factory-shipment state.
 Please refer Operating Manual.

Continue? [Y,N]?_

e4991ase067

Step 5. Press **[Y]** key on keyboard in the following case.

Continue? [Y,N]? Y

Step 6. Remove the system recovery disk from the floppy disk drive after confirming the following display.

“Please reset E4991A.”

A:\>

A:\> is indicated on the screen when the system recovery is complete.

Step 7. Shut down the E4991A by pressing the power switch.

Step 8. The E4991A will restart in the system recovery complete condition.

NOTE

System recovery can be suspended without execution by pressing **[N]** instead of **[Y]** Step 5. A:\> is also indicated on the screen after this section is made. Remove the system recovery disk and shut down the E4991A by pressing the power switch.

NOTE

If you do not have the system recovery disk, you can make it by the following procedure.

1. Copy the files (copydisk.exe, recover.bin) which are downloadable from CTU-kobe web site (internal) to specific directory on your PC.
2. Insert a floppy disk to the floppy disk drive in your PC.
3. Run the DOS prompt, and change the current directory to the specific directory which includes the above two files.
4. Perform the following command. Then, the system recovery disk will be made automatically.

“ copydisk.exe recover.bin a: “

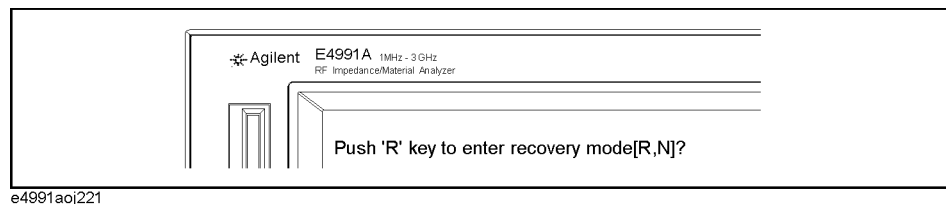
Procedure to execute system recovery (for serial number other than JP1KH or A27 that has been replaced)

Step 1. Shut down the E4991A.

Step 2. Connect the external keyboard to the E4991A.

Step 3. Press the standby switch of the E4991A to turn it on.

Step 4. When the message in the figure below appears on the screen following the Agilent's logo screen, immediately press **[R]** on the keyboard.



NOTE

Watch the message carefully because after several seconds it will be replaced with the next screen. Note that this is automatically done with no key operations.

Step 5. When "Recover Hard disk (C drive) [Y, N]?" is displayed, press **[Y]** on the keyboard. If you want to quit the system recovery, press **[N]** to start up the E4991A as usual.

System Installation for A27 Mass Storage System Recovery (for serial prefix JP1KH, JP2KH, and MY432)

- Step 6.** The following message appears. This is the final confirmation message asking whether you want to start the system recover. Press Y on the keyboard to start the system recovery. If you want to quit the system recovery, press N to start up the E4991A as usual.

```
=====  
SYSTEM RECOVERY  
=====
```

This process will recover the system drive (C:) of this instrument to the factory-shipment state. It takes about 10 minutes. Please refer to the Operation Manual for more information.

This is the last chance to quit the recovery process

Continue [Y,N]?

- Step 7.** The system recovery will be completed in about 10 minutes. The following message is displayed during the system recovery.

```
=====  
SYSTEM RECOVERY IN PROGRESS...  
=====
```

System recovery in progress. It takes about 10 minutes.
Please DO NOT TURN THE POWER OFF DURING THIS TIME.

CAUTION

Never turn off the power during the system recovery because doing so may cause serious damage to the E4991A.

- Step 8.** When the system recovery is completed, the following message appears below the above message indicating that the system recovery is in progress.

```
"Recovery Completed !"  
"Please any key and then restart system."
```

Now the system recovery of the E4991A is complete.

System Recovery (for serial prefix MY433 and later)

By executing system recovery, you can return the system of the E4991A (the Windows operating system and the firmware) to the factory state (at the time of purchase^{*1}).

Notes on executing system recovery


Executing system recovery causes the following:

- In addition to the Windows operating system and the firmware, the following settings of the E4991A are returned to the factory state.
 - Network setting
 - GPIB setting
 - Printer setting
- The driver for the supported printer installed after purchase is deleted.
- You need to execute initial registration again.

Files you created using the save function (files in the D drive) are not affected, but we recommend backing them up before executing system recovery for precautionary purposes. For more information on backup, refer to “Making Backup Files” as described in E4991A User’s Guide.

Procedure to execute system recovery (for serial prefix MY433 and later)

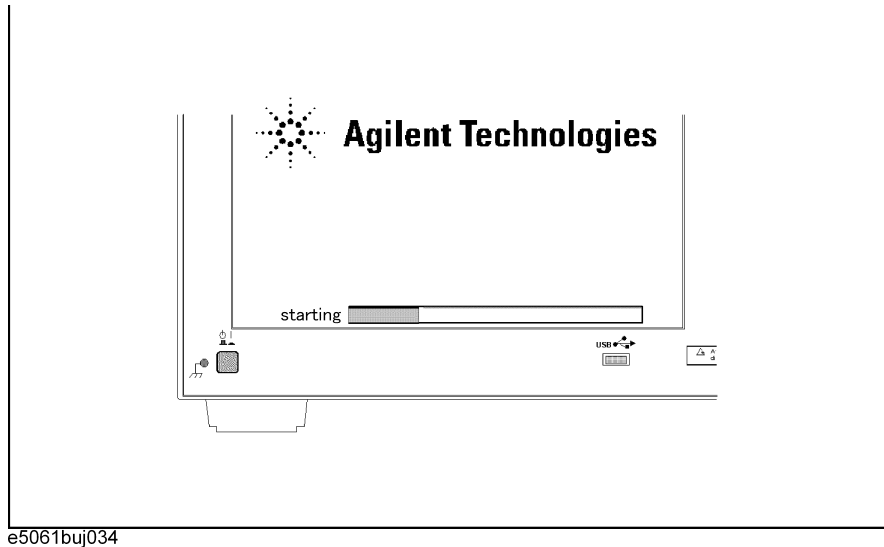
NOTE You need the keyboard for this operation.

- Step 1.** Shut down the E4991A.
- Step 2.** Connect the keyboard to the E4991A.
- Step 3.** Insert the disk for the system recovery which is furnished with the E4991A into the floppy disk drive of the E4991A.
- Step 4.** Press the standby switch of the E4991A to turn it on.
- Step 5.** When the screen as shown in the figure below appears, press and hold  of the keyboard

^{*1}. If the hard disk failed and has been replaced after purchase, the state when the replacement was performed is recovered.

System Installation for A27 Mass Storage
System Recovery (for serial prefix MY433 and later)

until this screen disappears.

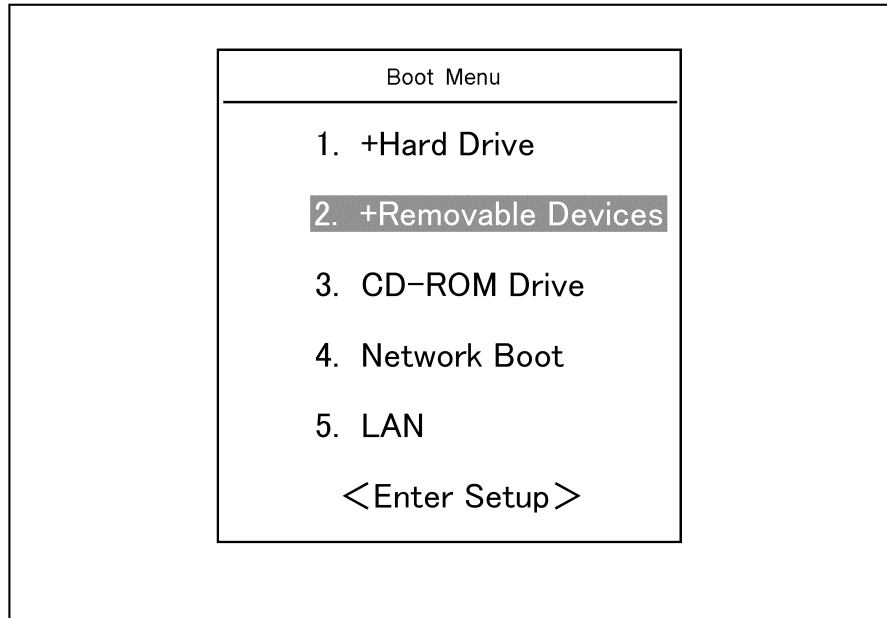


NOTE

After several seconds, the next screen appears automatically even if you do not press any key, so do not miss it.

If the above message does not appear, the instrument is at fault; contact your local Agilent customer center listed at the end of this manual or distributor.

Step 6. The following screen appears. Select “+Removable Devices” with of the keyboard, and press of the keyboard.



Step 7. The message as shown below appears. Press of the keyboard. If you want to cancel the system recovery, press here.

```

Agilent Technologies System Utilities
Recovery & Backup Options (for the E4991A)

```

Choose One of the following:

-
- ```

 1. Recover Factory Backup Image
 2. Exit

```
- 

Enter a Choice: \_

**NOTE**

If the above message does not appear, the instrument or the disk for the system recovery is at fault; contact your local Agilent customer center listed at the end of this manual or distributor.

System Installation for A27 Mass Storage  
System Recovery (for serial prefix MY433 and later)

**Step 8.** The message as shown below appears. Press **C** of the keyboard. If you want to cancel the system recovery, press **E** here.

You chose to Restore your system by installing the original factory installed OS and system software.

WARNING: Press C to Continue only if you are sure that you want to proceed. The C: Drive will be completely overwritten with no chance of recovering any data. Use Option 1 to recover the system from a serious malfunction caused by corrupted or inadvertently deleted files on the system's primary C: partition.

Press C to Continue or E to Exit: \_

**Step 9.** The system recovery will be complete in about 5 minutes. When the system recovery is complete, the message as shown below appears. Press **Ctrl**, **Alt**, and **Delete** of the keyboard at the same time to restart.

Remove the disk and Press CLT+ALT+DEL to restart your system.

---

**NOTE**

---

If the above message does not appear, the instrument is at fault; contact your local Agilent customer center listed at the end of this manual or distributor.

**Step 10.** After restart, the screen for initial registration appears. Execute initial registration. For information on the execution procedure, refer to “Initial Registration of E4991A (for serial prefix MY433 and later)” on page 321.

---

## Initial Registration of E4991A (for serial prefix MY433 and later)

When you start up the E4991A for the first time or after executing system recovery, you need to perform the initial registration of the Windows 2000 operating system of the E4991A.

---

**NOTE** You cannot use the front panel keys during the initial registration of the E4991A therefore connect the mouse and the keyboard before turning on the power.

---

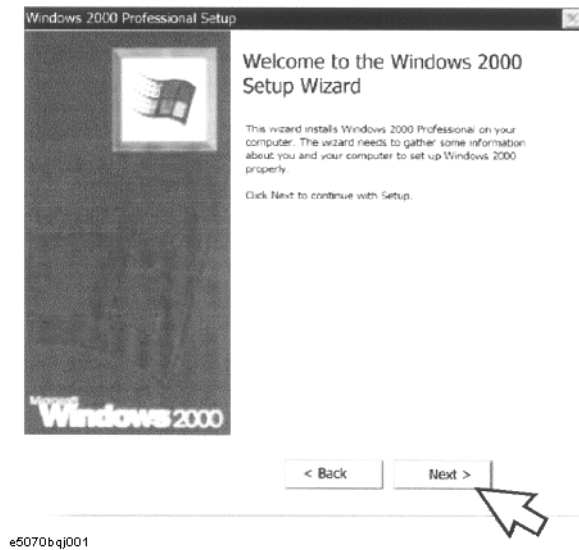
---

**NOTE** If you perform the following procedure incorrectly, a message asking you whether to return to the previous registration screen and perform the registration appears. In this case, follow the instruction to return to the previous registration screen.

---

- Step 1.** Turns on the E4991A.
- Step 2.** The Windows 2000 Professional Setup wizard appears. Click the **Next >** button (Figure B-4).

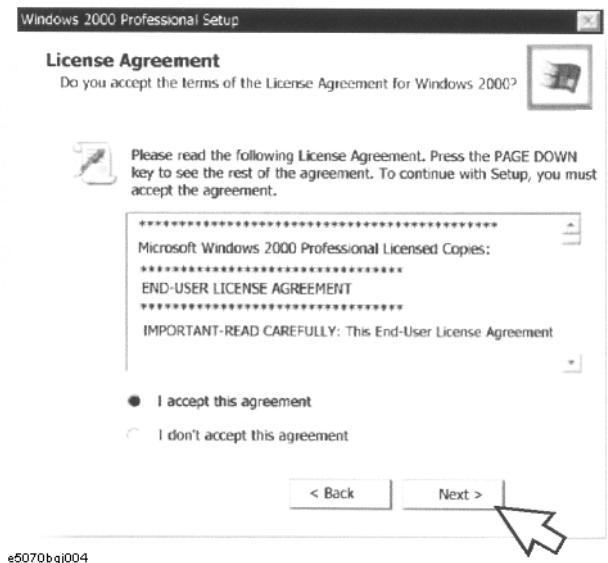
**Figure B-4** Windows 2000 Professional Setup wizard



System Installation for A27 Mass Storage  
Initial Registration of E4991A (for serial prefix MY433 and later)

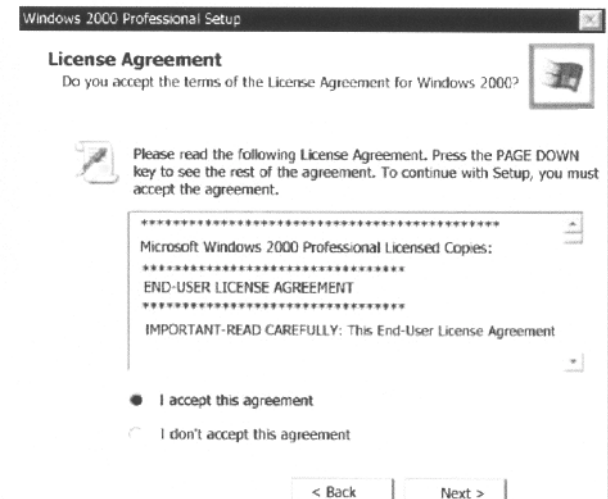
**Step 3.** In the Windows 2000 Professional Setup dialog box, select the **I accept this agreement** box and click the **Next >** button (Figure B-5). Then, the Windows 2000 operating system is restarted automatically.

**Figure B-5** Windows 2000 Professional Setup dialog box



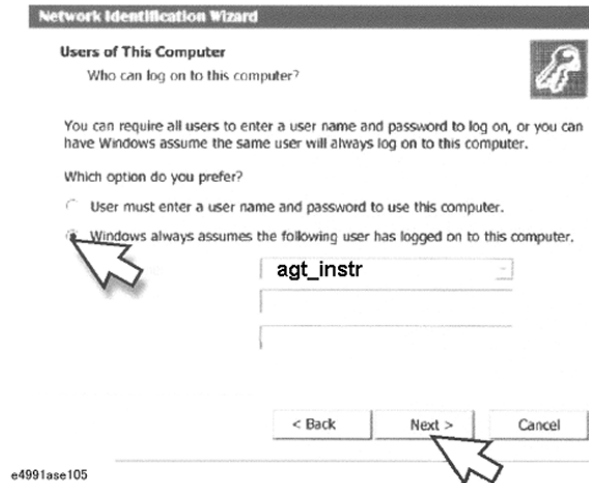
**Step 4.** The Network Identification wizard appears. Click the **Next >** button (Figure B-6).

**Figure B-6** Network Identification wizard



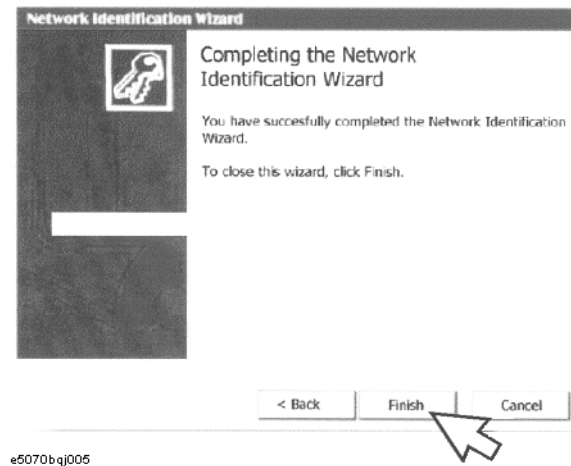
- Step 5.** In the Network Identification Wizard dialog box (1/2), select the **Windows always assumes the following user has logged on to this computer** box and check that **agt\_instr** is in the **User Name** box. If not, type in **agt\_instr**. Finally, click the **Next>** button (Figure B-7).

**Figure B-7** Network Identification Wizard dialog box (1/2)



- Step 6.** In the Network Identification Wizard dialog box (2/2), click the **Finish** button to finish the initial registration of the E4991A (Figure B-8). Then, the measurement display of the E4991A appears.

**Figure B-8** Network Identification Wizard dialog box (2/2)



System Installation for A27 Mass Storage  
**Initial Registration of E4991A (for serial prefix MY433 and later)**



---

## **C** **Firmware Update**

This appendix describes how to update the E4991A firmware. When you want to update the E4991A firmware, refer to this appendix.

---

## Firmware Update

### Required Equipment

- E4991A (with keyboard and mouse)
- Three blank floppy disks (DOS format)

### How to make the E4991A Firmware Installation Disk

The following is the procedure to make the E4991A Firmware Installation Disk.

**Step 1.** Copy the following files from Agilent Technologies web site to the three floppy disks using your computer's FDD.

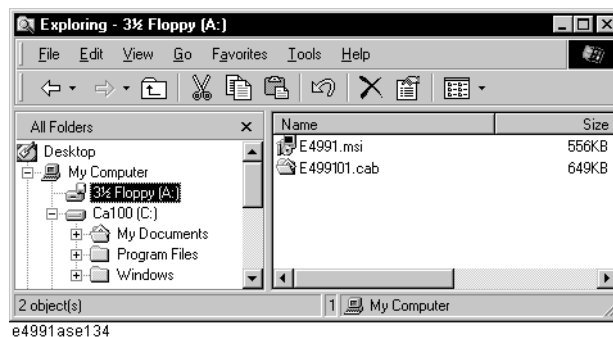
- disk1(1 of 3)-- e4991a.msi, e499101.cab
- disk2(2 of 3)-- e499102.cab
- disk3(3 of 3)-- e499103.cab

**Step 2.** Assign the Label name as follows using the properties of your computer's Windows Explorer as shown in Figure C-1.

- DISK\_1 (for disk1)
- DISK\_2 (for disk2)
- DISK\_3 (for disk3)

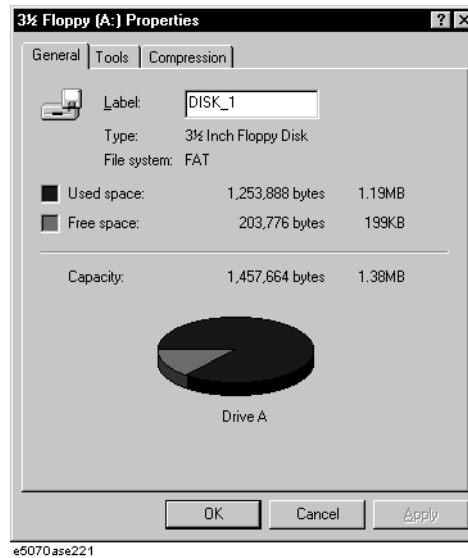
Figure C-1

### Windows Explorer (example)



1. Insert the disk1(1 of 3) into the FDD of your computer.
2. On the Windows Explorer, click **3 1/2 Floppy [A:]** and confirm the files.
3. Right click on **3 1/2 Floppy [A:]**, then click **Properties**. The Properties dialog box appears.
4. Enter the Label name in the Label box of properties dialog box (General) for the disk1 as shown in Figure C-2, and press the **OK** button.

Figure C-2 Properties Dialog Box (example)



5. Perform 1 through 4 for each disk.

**NOTE**

If the label name is not assigned, the firmware update for the E4991A will not be done correctly.

**How to update the E4991A firmware**

It is possible to update the E4991A firmware, but not the following software by this procedure.

- OS (Operating System)
- VBA (Visual Basic for Application)
- Calibration Constant Data

The following is the procedure to update the E4991A firmware.

- Step 1.** Prepare the E4991A firmware installation disks (three disks).
- Step 2.** Connect the mouse and the keyboard to the E4991A rear panel. Then turn the E4991A on.
- Step 3.** Exit from the E4991A Measurement Display.
  - 1. Click **System - Exit** on the menu bar, and the Enter Password to exit dialog box will appear.
  - 2. Enter the password **e4991a** into the Password box.
  - 3. Click the **OK** button. Then windows desktop screen is displayed.
- Step 4.** Double-click the “**My Computer**” icon on the Windows desktop.
- Step 5.** Insert the E4991A firmware installation disk1 (1 of 3) into the FDD of the E4991A.
- Step 6.** Double-Click the “**3 1/2 Floppy [A:]**” icon.

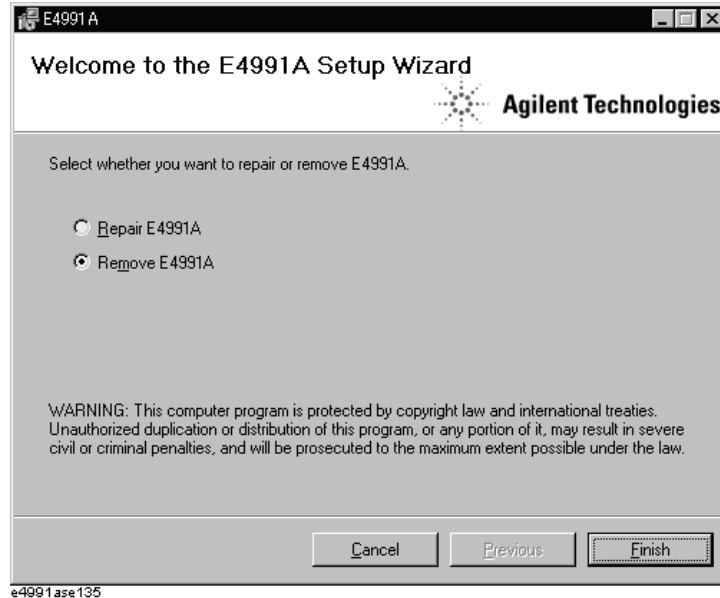
## Firmware Update Firmware Update

**Step 7.** Remove the old version of the firmware using the following procedure.

1. Double-Click “**E4991.msi**” icon. The E4991A Setup Wizard(uninstall) will start automatically as shown in Figure C-3.
2. Click on the **Remove E4991A** option button on the E4991A Setup Wizard as shown in Figure C-3, then click on the **Finish** button.
3. Click on the **Close** to exit the “Installation Complete” window.

**Figure C-3**

### E4991A Setup Wizard (uninstall)

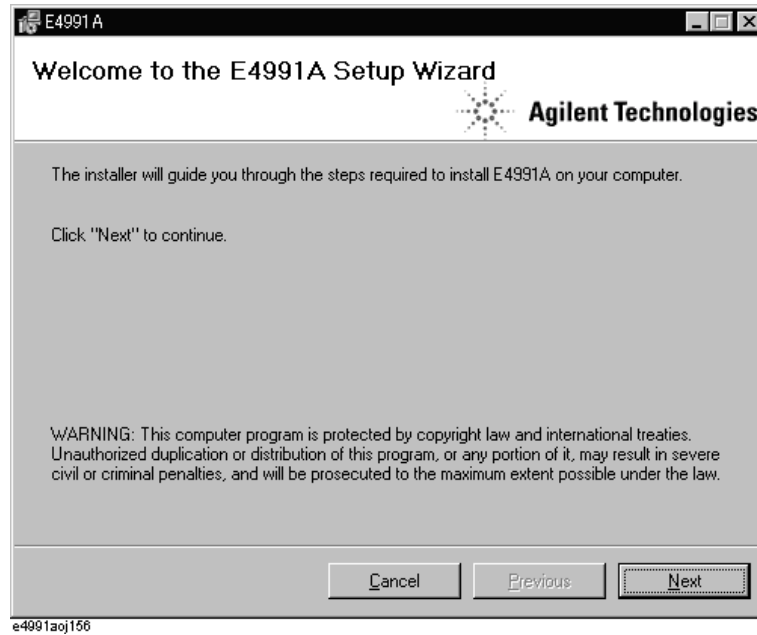


**Step 8.** Install the new version of the firmware using the following procedure.

1. Double-Click “**E4991.msi**” icon. The E4991A Setup Wizard will start automatically as shown in Figure C-4.
2. Click on the **Next** to continue the firmware installation on the E4991A Setup Wizard as shown in Figure C-4.
3. Click on the **Next** to start the firmware installation on “Confirm Installation” window.
4. After the disk1 installation is finished, insert the firmware installation disk2 (2 of 3) into the FDD of the E4991A, then click **OK**.
5. After the disk2 installation is finished, insert the firmware installation disk3 (3 of 3) into the FDD of the E4991A, then click **OK**
6. Click on the **Close** to exit on the “Installation Complete” window.

Figure C-4

E4991A Setup Wizard



**Step 9.** Shutdown the E4991A by the following procedure.

1. Click **Start - Shut Down...**
2. Click the **Shut down** button in the **Shut Down Windows** dialog box to select it.
3. Click the **OK** button.

**Step 10.** Turn on the E4991A, and then click **System - About E4991A....** Confirm the firmware revision you have just installed.

Firmware Update  
**Firmware Update**

---

**D**      **Power Requirement**

## Preparation for Power Supply

Before turning on power to the equipment, be sure to verify the following:

### Power Requirements

The E4991A requires the following power source:

|                           | Requirements                       |
|---------------------------|------------------------------------|
| Voltage                   | 90 to 132 VAC or 198 to 264 VAC *1 |
| Frequency                 | 47 to 63 Hz                        |
| Maximum power consumption | 350 VA                             |

\*1. Switched automatically by the E4991A in conformity to the voltage.

### Power Cable

In accordance with international safety standards, this instrument is equipped with a three-wire power cable. When connected to an appropriate ac power outlet, this cable grounds the instrument frame. The type of power cable shipped with each instrument depends on country of destination. Refer to Figure D-1 for the part numbers of the power cables available.

---

#### WARNING

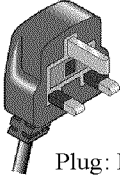
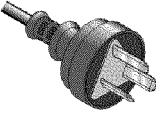
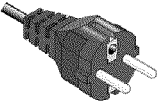
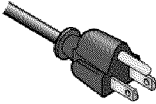


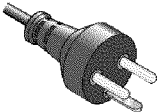
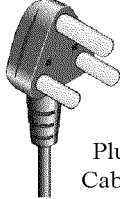
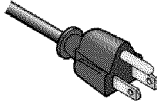
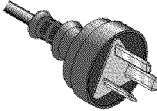
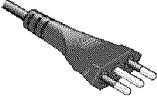
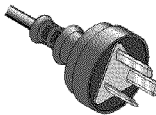
**For protection from electrical shock, the power cable ground must not be defeated.**

**The power plug must be plugged into an outlet that provides a protective earth ground connection.**

---



Figure D-1 Power cable options

|                                                                                                                                                                                                     |                                                                                                                                                                                                         |
|-----------------------------------------------------------------------------------------------------------------------------------------------------------------------------------------------------|---------------------------------------------------------------------------------------------------------------------------------------------------------------------------------------------------------|
| <p>OPTION 900</p>  <p>United Kingdom</p> <p>Plug: BS 1363/A, 250V, 10A<br/>Cable: 8120-1351, 8120-8705</p>         | <p>OPTION 901</p>  <p>Australia/New Zealand</p> <p>Plug: AS 3112, 250V, 10A<br/>Cable: 8120-1369</p>                 |
| <p>OPTION 902</p>  <p>Continental Europe</p> <p>Plug: CEE 7 Standard Sheet VII, 250V, 10A<br/>Cable: 8120-1689</p> | <p>OPTION 903</p>  <p>U.S./Canada</p> <p>Plug: NEMA 5-15P, 125V, 10A<br/>Cable: 8120-1378</p>                        |
| <p>OPTION 904</p>  <p>U.S./Canada</p> <p>Plug: NEMA 6-15P, 250V, 6A<br/>Cable: 8120-0698</p>                       | <p>OPTION 906</p>  <p>Switzerland</p> <p>Plug: SEV Type 12, 250V, 10A<br/>Cable: 8120-2104</p>                       |
| <p>OPTION 912</p>  <p>Denmark</p> <p>Plug: SR 107-2-D, 250V, 10A<br/>Cable: 8120-2956</p>                        | <p>OPTION 917</p>  <p>India/Republic of S. Africa</p> <p>Plug: IEC 83-B1, 250V, 10A<br/>Cable: 8120-4211</p>       |
| <p>OPTION 918</p>  <p>Japan</p> <p>Plug: JIS C 8303, 125V, 12A<br/>Cable: 8120-4753</p>                          | <p>OPTION 920</p>  <p>Argentina</p> <p>Plug: Argentine Resolution 63, Annex IV, 250V, 10A<br/>Cable: 8120-6870</p> |
| <p>OPTION 921</p>  <p>Chile</p> <p>Plug: CEI 23-16, 250V, 10A<br/>Cable: 8120-6978</p>                           | <p>OPTION 922</p>  <p>China</p> <p>Plug: GB 1002, 250V, 10A<br/>Cable: 8120-8376</p>                               |

NOTE: Each option number includes a 'family' of cords and connectors of various materials and plug body configurations (straight, 90° etc.).





power\_e

D. Power Requirement




## Turning the Power ON and OFF

Perform the following steps to turn the power ON or OFF.

### Turning the power ON

- Step 1.** If the standby switch (  ) in the lower-left part of the front panel is in the pressed down (  ) position, press the switch to the popped up position (  ).
- Step 2.** Press the standby switch to the pressed down position (  ).  
This operation turns ON the power, and the E4991A starts the self-test.
- Step 3.** Confirm that the self-test indicates normal operation.  
Normal operation is confirmed by the self-test if no error message appears.


### Turning the power OFF

- Step 1.** Use either of the following methods to turn OFF the E4991A.
- Press the standby switch (  ) in the lower-left part of the front panel (now in the pressed down (  ) position) to the popped up (  ) position.
  - Send the shutdown command from an external controller.

These operations will start the E4991A shutdown process (required software and hardware processes for turning the power off), and the power will turn OFF after a few seconds.

---

#### NOTE

Under normal circumstances, always press the standby switch (  ), or send the shutdown command from the external controller, to actuate the E4991A shutdown process. **Never cut off the power supply directly by disconnecting the power cable plug from the rear panel of the unit.**

If the power supply is cut off directly by disconnecting the power cable plug or by disconnecting the power supply to the AC outlet, the shutdown process will not be carried out, and there is a risk of damage to the software or hardware of the E4991A.

---

---

## **E** Messages

The E4991A can display error messages as well as messages that indicate the internal operating status of the equipment. This appendix explains what these messages mean by listing them in alphabetical order.

Messages showing the status of the E4991A are displayed in the lower-left area of the E4991A LCD screen. These messages include error messages that occur during the execution of GPIB commands and others that indicate the internal status of the equipment.

Error messages are indicated following the character string “[Err]” and can be read out by a GPIB command. Other kinds of messages are indicated without the “[Err]” character string and cannot be read out by a GPIB command. This section explains the meaning of each message and how to resolve the problem it indicates.

---

## Alphabetical Order

Errors with negative error numbers are basically general errors for GPIB instruments defined by IEEE488.2. On the other hand, errors with positive error numbers have been defined specifically for the E4991A.

### A

6

#### **Additional standards needed**

Before completing data measurement that requires calculation of the calibration coefficient, a GPIB command is sent to turn the calibration function On. For example, when only measurement of the Open Standard and Short Standard, but not the Load Standard, of the calibration kit has been completed, the SENS:CORR1:COLL:SAVE command is attempted in order to set the calibration function On.

Measure all of the necessary calibration data.

### B

-168

#### **Block data not allowed**

Block data is received at a position where the E4991A cannot allow a block data element.

### C

10

#### **Cal measure aborted**

One of the following problems has occurred.

- During measurement of the necessary calibration/fixture compensation data, or during and after the calculation of calibration/fixture compensation coefficients (with calibration function turned On), the settings of calibration/fixture compensation acquired data points (**Fixed, Full Range, Fixed, User Pwr** or **User Freq & Pwr**) have been altered. All measured calibration/fixture compensation data acquired thus far and/or the calibration/fixture compensation function have been invalidated.
- While the calibration/fixture compensation acquired data point setting is in the user-defined point condition (**User Freq & Pwr**), the sweep condition (Sweep Range, Sweep Parameter, Measurement Points, and Sweep Type) has been altered during measurement of the necessary calibration/fixture compensation data, or during and after the calculation of calibration/fixture compensation coefficients (with the

calibration function turned On). All measured calibration/fixture compensation data acquired thus far and/or the calibration/fixture compensation function have been invalidated.

- During measurement of the necessary calibration data, the measurement has been interrupted by the **Abort Cal Meas** button. The calibration data have been invalidated.

In order to recover the calibration/fixture compensation function or the equipment setting valid just prior to the event, click the **Recover Cal/Compen** state button. Also, if necessary, retry measurement of the calibration/fixture compensation data.

7 **Calibration required**

While the calibration function is not set to On, a GPIB command has been sent even though that command can only be executed while the calibration function is On. For example, when the calibration function is Off, the SENS:CORR2:COLL command has been attempted in order to measure fixture compensation data.

After measuring all necessary data, turn the calibration function On.

31 **Can't calculate equivalent parameters**

The measured data are not suitable for approximate calculation into the equivalent circuit parameters selected in the equivalent circuit model.

Retry measurement or select an appropriate equivalent circuit model.

62 **Can't execute data examination**

Even though the data for statistic analysis has been acquired, an attempt has been made to read out the statistic analysis results by changing the setting conditions (such as sweep start rate) and using the CALC{1-5}:MST:DATA? command before the measurement has been updated.

After changing the setting conditions, wait for the measurement to be updated and then read out the statistic analysis results.

-148 **Character data not allowed**

Character data has been received at a position where the E4991A cannot allow a character data element. For example, when the program message "CALC1:MARK:FUNC:TARG MAX" is sent instead of the correct program message "CALC1:MARK:FUNC:TARG le-12", the character data element is regarded by the E4991A as invalid.

Refer to the command reference and check the parameter to be used for that command.

-100 **Command error**

An error has occurred for which the E4991A could not grammatically specify the error message. This shows that a command error defined by IEEE488.2,5.1.1.4 has occurred.

13 **Comp measure aborted**

During measurement of the necessary fixture compensation data, the measurement has been interrupted by the **Abort Compen Meas** button. The fixture compensation data has been invalidated.

Retry measuring the fixture compensation data if necessary.

- 11                   **Compensation Required**
- Before finishing the measurement of fixture compensation data, a command has been sent to turn the fixture compensation function On. For example, before measurement of Open Compensation Data has been finished, the SENS:CORR2:COLL:OPEN command has been attempted in order to set the Open Compensation Function in the fixture compensation functions to On.
- Measure the necessary fixture compensation data.
- D**
- 230                   **Data corrupt or stale**
- Data may be invalid. Also, a newly reading procedure may have been started but not completed since the most recent access.
- 222                   **Data out of range**
- A data element well out of the E4991A's defined range (but not violating the standard) has been received.
- 104                   **Data type error**
- The parser has recognized a data element that is not supposed to exist. For example, even though numerical figure or character string data are expected, block data have been sent.
- Define the type of recognized data.
- E**
- 200                   **Execution error**
- An execution error has occurred for which the E4991A could not specify the error message. This code shows that an execution error defined in IEEE488.2, 11.5.1.1.5 has occurred.
- 123                   **Exponent too large**
- The absolute figure of the exponent has exceeded 32,000. (refer to IEEE488.2, 7.2.4.1).
- 178                   **Expression data not allowed**
- An expression data element has been received at a position where the E4991A does not allow expression data elements.
- 170                   **Expression error**
- During structure analysis of the expression data, there has been an error that does not apply to a situation between errors -171 and -179.

## F

-256

### File name not found

A designated file could not be found and the command has not been correctly executed. For example, attempts have been made to read and write on a file that does not exist or a disk has not been properly inserted.

95

### Frequency sweep only

A command that is only valid when the sweep parameter is in frequency has been sent. For example, when a sweep parameter other than frequency is set, the `CALC{1-5}:MARK:UNIT` command is attempted in order to set the marker X-axis display to relaxation time ( $1/2\pi f$ ).

First, use the `SWE:TYPE` command to set the sweep parameter to frequency.

## G

-105

### GET not allowed

While receiving a program message, the Group Execution Trigger (GET command in HTBasic) has been inputted (refer to IEEE488.2,7.7). For example, a wait command such as `*OPC?`, or `*WAI` has been sent.

## I

-224

### Illegal parameter value

The parameter value is not appropriate. For example, when the program message `"DISP:TRAC1:Y:SPAC OBAS"` has been sent instead of the correct program message `"DISP:TRAC1:Y:SPAC LOG"`, the parameter rate is regarded by the E4991A as inappropriate.

Refer to the command reference and confirm that the parameter value is correctly inputted.

71

### Impedance measurement mode only

A command has been sent that is only valid for Impedance Measurement Mode. For example, during the Magnetic Material Measurement Mode, the `SENS:CORR2:CKIT:STAN1:C` command has been attempted in order to define the user defined fixture compensation kit.

Select Impedance Measurement Mode.

-213

### Init ignored

Because another measurement is already underway, the Measurement Initialize Request (`"INIT"` command) has been ignored. For example, this happens when changing the setting of `"INIT:CONT"` to `"OFF"` and the `"TRIG:SOUR"` command to `"BUS"` or when attempting a trigger with the `*TRG` command. If the `"INIT"` command is sent to the E4991A before the sweep is completed (without a wait time), it is regarded as an invalid command.

-161

### Invalid block data

Even though the block data is expected, the received block data is invalid for some reason (refer to IEEE488.2, 7.7.6.2). For example, before the length of block data has been filled, an END message is received.

## Messages

### Invalid character

#### -101 **Invalid character**

In the error message character string, an invalid character has been found. For example, when a message "SENS:CORR1:COLL:FPO USER" is sent toward the proper program message; "SENS:CORR1:COLL:FPO&USER", the ampersand symbol (&) will be perceived by E4991A as an invalid character. In case the parameter is inputted at the end, provide space between the command and the parameter.

#### -121 **Invalid character in number**

There are invalid characters in the received data and type. For example, an alphabetic character has been found in a decimal numeric or a "9" has been found in octal data.

#### -171 **Invalid expression**

An expression data element is invalid (refer to IEEE488.2, 7.7.7.2). For example, the brackets are not paired or the character violates the standard.

#### 106 **Invalid file name**

During the execution of file save/recall command, the character string contained an inappropriate file name. For example, when executing a recall command, the file name extension was incorrect.

Specify an appropriate file name.

Also, when saving data on a floppy disk, this error message will be shown if the disk is not properly inserted or the disk is write-protected.

#### 77 **Invalid material size**

The definition of the size of the test material in a Magnetic Material Measurement is invalid. For example, an attempt has been made to set the outer diameter of the test material to a smaller figure than the inner diameter.

Set the outer diameter of the magnetic material to a larger size than that of the inner diameter.

#### -103 **Invalid separator**

When the parser (compiler) is expecting a separating symbol, a character that is not a separating symbol has been sent. For example, when the program message "SENS:CORR1:COLL:FPO USER \*OPC?" is sent instead of two program messages correctly separated by a semi-colon as "SENS:CORR1:COLL:FPO USER;\*OPC?" the instrument cannot perceive the separation. When sending two program messages simultaneously, be sure to insert a separating symbol such as a semi-column (;) between the two messages.

#### -151 **Invalid string data**

Even though character string data are expected, the received character string is invalid for some reason (refer to IEEE488.2, 7.7.2.4). For example, the END message has been received before the closing quotation mark character appeared.

#### -131 **Invalid suffix**

The suffix (here meaning Unit) does not following the sentence structure defined by IEEE488.2, 7.7.3.2, or the suffix is not appropriate for the E4991A. For example, when the program message "SOUR:VOLT:STAR 10dbm" has been sent instead of the correct program message "SOUR:VOLT:STAR 10mV", the suffix is regarded by the E4991A as invalid. Refer to the command reference to confirm the unit that should be used for this



command.

## M

-272

### Macro execution error

An execution error related to the E4991A's macro functions has occurred.

-261

### Math error in expression

A program data element that is a syntactically legal expression could not be executed due to a math error such as an attempted divide-by-zero.

-109

### Missing parameter

A parameter is insufficient for a command, or the parameter has not been inputted. For example, the **SWE:POIN** command requires 1 parameter, so when the program message "**SWE:POIN**" has been sent instead of the correct program message "**SWE:POIN 201**", it is regarded as invalid by the E4991A because no parameter has been inputted.

Make sure to input a parameter for any command that requires one.

32

### Must be more than 2 points for analysis

Measurement points within the sweep range are set to 2 (if the partial search function is On within the designated Searching range), so calculation of the equivalent circuit parameter (**Calculate Parameter** button or **CALC{1-5}:EPAR** command) could not be executed.

Measurement points within the sweep range (if the partial search function is On within the designated Searching range) must be set to 3 or above.

## N

92

### No active marker

Because the marker is not displayed, the sent command has been ignored. For example, when the marker is not displayed, the **CALC{1-5}:MARK:SET** command has been attempted in order to change the instrument setting of the E4991A.

First use the **CALC{1-5}:MARK{1-8}** command to show the marker on the display.

61

### No data available in memory

This occurs when the marker's Statistic Analysis Function (**Statistics** button) is Off and an attempt has been made to read out the statistic analysis result by using the **CALC{1-5}:MST:DATA?** command.

Turn the Marker's Statistic Analysis Function to On and acquire data for statistic analysis.

113

### No data trace displayed

Because the data trace is not displayed, the sent command has been ignored. For example, when the data trace is not displayed, the **CALC{1-5}:MARK:ON** command has been attempted in order to set a trace displaying a marker as the data trace.

First use the **CALC{1-5}:MATH:FUNC** command to display the data trace.

0

### (no error)

No error has occurred.

This message is not normally shown on the LCD display but returned after the

## Messages

### No fixed delta marker

SYST:ERR? command has been sent by GPIB. When the equipment finds no occurrence of an error, a message is returned as error number 0.

#### 94 **No fixed delta marker**

Because the reference marker is not set to fixed  $\Delta$  mode, the sent command has been ignored. For example, when the fixed  $\Delta$  mode is not set, the CALC{1-5}:MARK:REF:Y command has been attempted in order to set the reference marker to the designated measurement values.

First use the CALC{1-5}:MARK:REF command to display the reference marker. Next, use the CALC{1-5}:MARK:REF:TYPE command to change the setting to fixed  $\Delta$  mode.

#### 90 **No marker delta - parameter not set**

This occurs when the reference marker's  $\Delta$  mode is Off and the CALC{1-5}:MARK:SET command or CALC{1-5}:MARK:FUNC:DOM:SPAN command has been attempted in order to set the  $\Delta$  value to span value within the sweep range or within the partial search range.

First use the CALC{1-5}:MARK:REF command to display the reference marker. Next, use the CALC{1-5}:MARK:REF:TYPE command to set the  $\Delta$  Mode or Fixed  $\Delta$  Mode to On.

#### 114 **No memory trace displayed**

Due to the fact that memory trace is not displayed, a command that has been sent was ignored. For example, when the memory trace is not displayed, the DISP:TRAC{1-5}:Y:FOR command is attempted in order to set the scale setting subject as the data trace.

First use the CALC{1-5}:MATH:FUNC command to display the memory trace.

#### 30 **No Valid Memory Trace**

This occurs when there are no data stored in the Memory Trace and the CALC{1-5}:MATH:FUNC command has been attempted in order to display the Memory Trace.

Before displaying the Memory Trace, use the CALC{1-5}:MATH:MEM command to store the data into the Memory Trace.

#### 140 **Not allowed for the current trigger source**

An invalid command for the presently selected trigger source has been sent. For example, when the trigger source is set to internal trigger (**Internal**), the TRIG:EVENT command has been attempted in order to set the trigger event mode (detecting point for triggering) at each measurement point (**On Point**) or at each (**On Segment**). This operation is valid only when internal trigger is not set as the trigger source.

After setting the trigger source to **Manual**, **External** or **GPIB Bus**, change the Trigger Event Mode.

#### 14 **Not allowed in power sweep**

An invalid command has been sent to the oscillator level sweep while it is in progress. For example, during the oscillator level sweep, the SWE:TYPE command has been attempted in order to set the sweep type to log sweep. This operation is invalid during the oscillator level sweep.

Confirm that the command is valid for the oscillator level sweep.

#### 70 **Not allowed in this measurement mode**

A command has been sent that cannot be executed in the currently set measurement mode. For example, in the Dielectric Measurement Mode, the SENS:CORR1:CKIT command has been attempted in order to set the calibration kit to the defined calibration kit used.

Select a measurement mode in which the command is valid.

80 **Not available for this fixture**

An invalid command has been sent to the currently selected text fixture. For example, when the 16197A is selected, the CALC{1-5}:FORM command is attempted in order to set a prohibited measurement parameter (e.g. complex dielectric constant).

Select an appropriate measurement parameter or display format.

79 **Not available for this format**

The selected measurement parameter or display format could not be executed. For example, in the Dielectric Measurement Mode or in Magnetic Material Measurement Mode, the DISP:TRAC{1-5}:GRAT:FORM command is attempted in order to set a prohibited display format (Smith Chart or Admittance Chart).

Select an appropriate measurement parameter or display format.

47 **Not enough data**

The amount of data transferred to the E4991A by an external controller was less than the amount expected by the E4991A.

Match the amount of data to be transferred with the E4991A measurement points.

-120 **Numeric data error**

An error has been caused by numeric data (including nondecimal numeric types). In errors - 121 to - 129, an unspecified numeric error has occurred.

-128 **Numeric data not allowed**

A numeric data element has been received at a position where the E4991A does not allow numeric data elements. For example, when the program message "CALC1:FORM 3" has been sent instead of the correct program message "CALC1:FORM RS", the numeric data element is received by E4991A as invalid. Refer to the command reference and confirm which parameter should be used for a particular command.

**O**

48 **Option not installed**

Because a particular option has not been installed, the sent command has been ignored. For example, when the option 001 (DC bias function) is not installed, the SOUR:VOLT:OFFS command has been attempted in order to set up the DC bias voltage values.

Please contact your nearest Agilent Technologies branch office or the company where you purchased the instrument install the necessary options.

-321 **Out of memory**

There is a shortage of memory (RAM).

**P**

-108 **Parameter not allowed**

## Messages

### Permeability measurement mode only

The parameters have exceeded the number necessary for a command.

For example, when the program message "**SWE:TYPE LIN,SEGM**" is sent instead of the proper program message "SWE:TYPE LIN", 2 parameters are sent even though only 1 parameter is required for this command. Therefore, the number of parameters is regarded as invalid by the E4991A.

Refer to the command reference and check the number of parameters required.

73

### Permeability measurement mode only

A command that is only valid for Magnetic Material Measurement Mode has been sent. For example, in the Dielectric Measurement Mode, the **CALC:FORM:PAR:MGA** command has been attempted in order to set the size of the magnetic substance.

Select Magnetic Material Measurement Mode.

72

### Permittivity measurement mode only

A command that is only valid for Dielectric Measurement Mode has been sent. For example, in the Magnetic Material Measurement Mode, the **SENS:CORR1:CKIT:STAN7:THIC** command has been attempted in order to set the thickness of the load standard for Dielectric Measurement.

Select Dielectric Measurement Mode.

22

### Printer error

The printer has not responded to the control from the E4991A.

Confirm whether the printer's power is On or Off, the connection status of the cable, and the paper supply.

-112

### Program mnemonic too long

The length of a header has exceeded 12 characters. The length of a header here refers to the length of the series of characters that are separated by colons (:).

Refer to IEEE488.2,7.6.4.1 for further details.

## Q

-430

### Query DEADLOCKED

This indicates a condition that has created a "DEADLOCK" Query error (refer to IEEE488.2, 6.3.1.7). This error occurs, for example, when both input and output buffers become full and when the E4991A is no longer able to carry out a process.

-400

### Query error

The E4991A has found a Query error for which it is not able to specify the error message. This code shows that a Query error defined in IEEE488.2, 11.5.1.1.7 or 6.3 has occurred.

-410

### Query INTERRUPTED

This indicates a condition that has created an "INTERRUPTED" Query error (refer to IEEE488.1, 6.3.2.3). This error is generated when, for example, the data byte "DAB" or Get is received after the Query but before its response is fully sent.

-420

### Query UNTERMINATED

This indicates a condition that has created an "UNTERMINATED" Query error (refer to IEEE488.1, 6.3.3.2). This error occurs when the E4991A is designated as a talker (if designated as a controller, data transmission is possible via the interface) and receives

## Query UNTERMINATED after indefinite response

incomplete program messages. For example, when a command that does not require a Query, such as "**\*CLS**", has been sent as "**\*CLS?**", it is regarded as an incomplete message by the E4991A.

Check the command reference.

-440 **Query UNTERMINATED after indefinite response**

This indicates that a query has been received in the same program message after a query requesting an indefinite response has been executed (refer to IEEE488.2, 6.5.7.5.7).

**R**

105 **Recall error**

An error has occurred during reading out (recall) of a file. For example, this occurs when an attempt is made to read out a file containing invalid data (such as the extension (.sta) for instrument state files that were saved with equipment other than the E4991A).

Confirm that there is no problem in the file contents.

**S**

104 **Save error**

While saving a file, an error has been detected on the media in which the data is to be stored. For example, when saving the file to a floppy disk, the space available in the floppy disk is not sufficient.

Check the amount of available space in the media in which the data is to be stored.

118 **Segment table empty or insufficient table**

Because the segment sweep table has not been created, a sent command has been ignored. For example, before the segment sweep table is created, the SWE:TYPE command is attempted in order to set a sweep type as the segment sweep.

Before carrying out a segment sweep, create the segment sweep table.

-221 **Settings conflict**

Even though the program data element has been received and it conforms to the standard, execution is not possible with the present condition of the E4991A.

-150 **String data error**

An error caused by a received series of character data elements (quotation mark character) has occurred. In errors - 151 to - 159, an unspecified character string error has occurred.

-158 **String data not allowed**

A string data element has been found at a position where the E4991A does not allow string data elements. For example, when the program message "**TRIG:SOUR "MAN"**" has been sent instead of the correct program message "**TRIG:SOUR MAN**", the double quote (") is regarded by the E4991A as invalid.

Refer to the command reference and confirm whether the double quote (") is required in the parameter of a particular command.

-138 **Suffix not allowed**

## Messages

### Suffix too long

A suffix has been added after numeric data where a suffix (here meaning Unit) cannot be inputted. For example, when the program message "**DISP:TRAC1:Y:PDIV 0.01rad**" has been sent instead of the correct program message "DISP:TRAC1:Y:PDIV 0.01", the suffix is regarded by E4991A as invalid.

Refer to the command reference and confirm that the suffix can be added to the numeric data element.

#### -134 **Suffix too long**

The suffix (here meaning Unit) display is written with more than 12 characters (refer to IEEE488.2, 7.7.2.4).

#### -102 **Syntax error**

An unrecognized command or data type has occurred. For example, when the program message "**SYST:POFF**" is sent instead of the proper program message "**SYST::POFF**", a colon (:) has been incorrectly inserted, and it will be perceived by the E4991A as an unrecognized command.

Delete one colon (:) in order to send the appropriate command.

#### -310 **System error**

In the E4991A, one of the so called "System Errors" has occurred.

## T

#### -124 **Too many digits**

The mantissa of a decimal numeric data element exceeds 255 excluding leading zeros (refer to IEEE488.27.7.2.4).

#### 69 **Too many segments or points**

While editing the list sweep table, a setting has been attempted that exceeds the maximum number of segments (16), the maximum number of measurement points (201) per segment, or the maximum number of total measurement points (801) in all segments.

During setting, the numbers of segments or measurement points should not exceed the maximum figures.

#### -223 **Too much data**

This occurs when the amount of data exceeds the E4991A's memory capacity, even though the program data received in a block, expression, or character string conforms to the standard. The occurrence of this error indicates that the problem is restricted to the memory or memory related devices.

#### -211 **Trigger ignored**

The trigger command "**\*TRG**" or an external trigger signal has been received and detected by the E4991A but was ignored because of the timing (for example, the E4991A trigger was not in the waiting condition).

Prepare for the trigger command or external trigger signal when the trigger is in the waiting condition.

## U

#### -113 **Undefined header**

A command not defined by the E4991A has been received, although grammatical structure does not provide any problem. For example, when the program message "**DISP:TRAC1:X:AUTO**" has been sent instead of the correct program message "**DISP:TRAC1:Y:AUTO**", it is received by the E4991A as an undefined command.

Refer to the command reference and check the correct commands.

15

**User cal mode only**

Setting has been attempted by using commands to define each standard of the calibration kit before selecting a user defined calibration kit.

First select the calibration kit that will be used as the user defined calibration kit. Then define each standard value for this calibration kit.

## Messages indicating the internal status of the equipment

Messages that indicate the internal status of the equipment include equipment irregularities as well as the results of processing (or current processing status). These messages do not have numbers.

### Messages indicating measurement failure

#### DC bias overload

During application of DC bias voltage, a sudden change in the connection condition of the DUT has lowered the direct-current impedance, resulting in momentary over-current at the DC bias source.

Do not remove the DUT during application of DC bias. If this error occurs frequently during normal measurement, this may be due to instrument failure.

#### PLL Unlock

An error has been detected in the internal PLL (Phase Lock Loop) circuit of the E4991A. The PLL is used to generate a stable frequency source. This can occur due to an error of the external reference signal or when the power is turned ON in a low-temperature environment.

If the external reference signal has not been inputted or shows no error, instrument tuning or repair is necessary. If the message does not disappear in a few minutes after turning the power ON, instrument tuning or repair is necessary.

#### Power on test failed

An error has been detected during the self-test after turning on the power.

#### RF overload

There has been a ranging failure in the internal circuit due to a sudden change in impedance caused by removing the DUT or some other reason during measurement.

Do not remove the DUT during measurement. If this error occurs frequently during normal measurement, there may be instrument failure.



## Messages indicating the results (or current status) of processing

### **Cal done**

Calculation and storage of a calibration coefficient completed.

### **Cal measure aborted**

Measurement of calibration data aborted.

### **Comp done**

Calculation and storage of a fixture compensation coefficient completed.

### **Comp measure aborted**

Measurement of a fixture compensation coefficient aborted.

### **Peak not found**

Peak search function executed, but no defined peak was found.

### **Target value not found**

Target search function executed, but no target measurement value was found.

### **Trigger hold**

Measurement is in hold mode, in which a trigger is not accepted.

### **Wait -- measuring cal standard**

Calibration data are now being measured.

### **Wait -- measuring comp standard**

Fixture compensation data are now being measured.

Messages

**Wait -- measuring comp standard**